

### Features

- Increase in DC pressure ratings to AC levels on all products (up to a 500% improvement)
- Lower power operation
- Voltage ranging
- Built-in surge suppression
- Elimination of AC hum
- Increase in AC and DC operating temperatures
- Low solenoid temperature rise
- Longer coil life due to lower operating temperatures and electrical surge suppression
- Solenoid approvals to UL, CSA, and CE directives
- Available with Class I, Division 2 coils (EE prefix)
- RoHS 2 Compliant

### Nominal Ambient Temp. Ranges

14°F to 140°F (-10°C to 60°C)

For 8262/8263/8314 Series: -13°F to 140°F (-25°C to 60°C)

### How to order

Find the valve that you are looking for in the provided specifications tables.

The tables contain the following information designed to help you in making your selection:

Pipe Size (in)	Orifice Dia. (in)	Cv Flow	Operating Pressure Differential (psi)				Max Fluid Temp. °F	Brass ①	Const. Ref.	Agency			Const. Ref.	Agency		Approx. Shipping Weight (lbs.)
			Min.	Max.		UL				Stainless Steel	UL	DC		AC/D		
				Air-Inert Gas	Water										Light Oil @ 300 SSU	
1/2	5/8	4	0	150	150	-	180	8210P094	4	○	-	-	-	1.0	1.5	3.2

① When ordering a valve product, specify the ASCO base catalog number (Ex. **8210P094**). This number will always be 8 digits long.

Choose one of the three operating voltage ranges (100-240V/50-60Hz/DC, 24-120V/50-60Hz/DC or 12-24/DC) and add it to the base catalog number (Ex. 8210P094 **24-120V/50-60Hz/DC**).

If you want to enhance the product with one or more of the options allowed in the Optional Features Chart for that catalog number, please add the appropriate prefix or suffix (as shown):

Pipe Size (in)	Orifice Dia. (in)	Solenoid Options ②	Base Catalog Number		Resilient Materials ③								Other ③		Standard Rebuild Kit ④	
		Class I, Division 2 Coil	Brass	Stainless Steel	NBR	FKM	EPDM	CR	Oxygen Service	PTFE	Urethane	Vacuum	Manual Operator	Mounting Bracket	Brass	Stainless Steel
1/2	5/8	EE	8210P094	-	●	V	E	J	N	-	-	VH	MO	MB	322670	-

② Optional Class I, Division 2 solenoid (Ex. **EE8210P094** 24-120V/50-60Hz/DC)

③ If an FKM elastomer and manual operator are required, add VMO to the back of the base catalog number. (Ex. 8210P094**VMO** 24-120V/50-60Hz/DC)

④ When ordering a rebuild kit for a valve, supply the rebuild kit number as shown in the table. (Ex. 322670) When ordering a rebuild kit for a valve with a suffix, add the suffix to the appropriate standard rebuild kit. (Ex. The rebuild kit for the above valve with FKM is 322670-V)

All constructions are available with prefix EE for Class I, Division 2 requirements.

When ordering a replacement coil, select from the following:

Voltage Range	Valve Prefix	Replacement Coil Part Number
100-240V/50-60Hz/DC	-	250404-605-*
24-120V/50-60Hz/DC	-	250404-606-*
12-24/DC	-	250404-607-*
100-240V/50-60Hz/DC	EE	250504-605-*
24-120V/50-60Hz/DC	EE	250504-606-*
12-24/DC	EE	250504-607-*

### Solenoid Enclosures

**Standard:** Watertight, Types 1, 2, 3, 3S, 4, and 4X.

**Optional:** Class I, Division 2 for Hazardous Locations and Watertight, Types 3, 3S, 4, 4X. (To order, add prefix "EE" to catalog number.)

### Note

See Engineering Section for valve parts in contact with fluids

and additional information

服务热线: 4006-918-365  
网址: <http://www.ivalve.cc>

传真: (86-532)585-10-365

Email: [sales@bechinass.com](mailto:sales@bechinass.com)



ELECTRONICALLY  
ENHANCED

### 3-Way Features

- Three-way (3/2) Next Generation solenoid valves have three ports and two orifices. When one orifice is open, the other is closed
- Control of air, water, light oil, and other non-corrosive media
- Normally closed (pressure to cylinder port when energized) operation
- Normally open (cylinder port exhausts when energized) operation
- Universal operation (can function as normally open, normally closed, diverter of fluid flow, or selector of 2 fluid sources configurable by piping)
- Pipe sizes – 1/4 to 3/4 inch

### 3-Way Specifications (English units)

Pipe Size (in)	Orifice Dia. (in)	Cv Flow	Operating Pressure Differential (psi)				Max. Fluid Temp. °F	Brass	Const. Ref.	Agency		Const. Ref.	Wattage		Approx. Shipping Weight (lbs.)			
			Min.	Max.						UL	Stainless Steel		DC	AC/DC				
				Air-Inert Gas	Water	Light Oil @ 300 SSU												
<b>General Service - Normally Closed</b>																		
1/8	3/64	0.05 ③	0	300	300	300 ⑦	200 ⑥	8314R031	1	●	8314R037	1	●	1.0 ⑧	1.5 ⑨	1.7		
1/8	3/32	0.15 ④	0	205	205	190 ⑦	200 ⑥	8314R032	1	●	8314R038	1	●			1.7		
1/8	1/8	0.25 ④	0	145	145	100 ⑦	200 ⑥	8314R033	1	●	8314R039	1	●			1.7		
1/4	3/64	0.05 ③	0	300	300	300 ⑦	200 ⑥	8314R034	2	●	8314R068	2	●			1.8		
1/4	3/32	0.15 ④	0	205	205	190 ⑦	200 ⑥	8314R035	2	●	8314R121	2	●			1.8		
1/4	1/8	0.25 ④	0	145	145	100 ⑦	200 ⑥	8314R036	2	●	8314R126	2	●			1.8		
1/4	5/32	0.50 ④	0	75	75	75 ⑦	200 ⑥	8314R130	2	●	8314R230	2	●			1.8		
1/4	7/32	0.70 ④	0	40	40	40 ⑦	200 ⑥	8314R131	2	●	8314R231	2	●			1.8		
1/4	9/32	0.85 ④	0	25	25	25 ⑦	200 ⑥	8314R132	2	●	8314R232	2	●			1.8		
1/4	5/64	0.12	0	232	232	232	180	8320P182	3	●	-	-	-			2.5		
1/4	7/64	0.23	0	150	150	150	180	8320P184	3	●	-	-	-			2.5		
1/4	5/32	0.35	0	75	75	75	180	8320P186	3	●	-	-	-			2.5		
1/4	3/32 ①	0.2 ①	5 ⑤	150	150	100	180	8317P035	4	●	-	-	-			2.7		
1/4	9/32 ②	0.8 ②	10	200	200	200	180	8321P001	5	●	-	-	-			3.8		
3/8	9/32 ②	0.8 ②	10	200	200	200	180	8321P002	5	●	-	-	-			3.8		
3/8	5/8	2.5	10	250	250	-	180	8316P054	6	●	-	-	-			4.9		
1/2	5/8	3.2	10	250	250	-	180	8316P064	6	●	-	-	-	4.9				
3/4	11/16	4.8	10	250	250	-	180	8316P074	7	●	-	-	-	5.1				
<b>NAMUR Mount - 3/2 Normally Closed</b>																		
1/4	3/32	0.12	-	150	-	-	180	8320P704	9	●	8320P714	9	●	1.0 ⑧	1.5 ⑨	3.2		
<b>General Service - Normally Open</b>																		
1/8	3/64	0.05 ③	0	300	300	300 ⑦	200 ⑥	8314R049	1	●	8314R055	1	●	1.0 ⑧	1.5 ⑨	1.7		
1/8	3/32	0.15 ④	0	175	175	175 ⑦	200 ⑥	8314R050	1	●	8314R056	1	●			1.7		
1/8	1/8	0.25 ④	0	160	160	160 ⑦	200 ⑥	8314R051	1	●	8314R057	1	●			1.7		
1/4	3/64	0.05 ③	0	300	300	300 ⑦	200 ⑥	8314R052	2	●	8314R069	2	●			1.8		
1/4	3/32	0.15 ④	0	175	175	175 ⑦	200 ⑥	8314R053	2	●	8314R122	2	●			1.8		
1/4	1/8	0.25 ④	0	160	160	160 ⑦	200 ⑥	8314R054	2	●	8314R070	2	●			1.8		
1/4	5/32	0.50 ④	0	150	150	150 ⑦	200 ⑥	8314R133	2	●	8314R233	2	●			1.8		
1/4	7/32	0.70 ④	0	100	100	100 ⑦	200 ⑥	8314R134	2	●	8314R234	2	●			1.8		
1/4	9/32	0.85 ④	0	65	65	65 ⑦	200 ⑥	8314R135	2	●	8314R235	2	●			1.8		
1/8	3/64	0.18	-	350	350	350	180	8320P136	8	●	8320P146	8	●			2.5		
1/4	1/32	0.05	-	790	825	825	180	8320P190	3	●	-	-	-			2.5		
1/4	5/64	0.12	0	210	210	210	180	8320P192	3	●	-	-	-			2.5		
1/4	7/64	0.23	0	150	150	150	180	8320P194	3	●	-	-	-			2.5		
<b>General Service - Universal Operation</b>																		
1/8	3/64	0.05 ③	0	200	200	200 ⑦	200 ⑥	8314R041	1	●	8314R042	1	●			1.0 ⑧	1.5 ⑨	1.7
1/8	3/32	0.15 ④	0	105	85	60 ⑦	200 ⑥	8314R043	1	●	8314R044	1	●					1.7
1/8	1/8	0.25 ④	0	70	70	40 ⑦	200 ⑥	8314R045	1	●	8314R040	1	●	1.7				
1/4	3/64	0.05 ③	0	200	200	200 ⑦	200 ⑥	8314R006	2	●	8314R123	2	●	1.8				
1/4	3/32	0.15 ④	0	105	85	60 ⑦	200 ⑥	8314R007	2	●	8314R120	2	●	1.8				
1/4	1/8	0.25 ④	0	70	70	40 ⑦	200 ⑥	8314R008	2	●	8314R124	2	●	1.8				
1/4	5/32	0.50 ④	0	35	35	35 ⑦	200 ⑥	8314R127	2	●	8314R227	2	●	1.8				
1/4	7/32	0.70 ④	0	18	18	18 ⑦	200 ⑥	8314R128	2	●	8314R228	2	●	1.8				
1/4	9/32	0.85 ④	0	10	10	10 ⑦	200 ⑥	8314R129	2	●	8314R229	2	●	1.8				
1/4	5/64	0.12	0	116	116	116	180	8320P172	3	●	-	-	-	2.5				
1/4	7/64	0.23	0	60	60	60	180	8320P174	3	●	-	-	-	2.5				
1/4	5/32	0.35	0	35	35	35	180	8320P176	3	●	-	-	-	2.5				

● = General Purpose Valve. ① 1/4" exhaust orifice with 0.73 Cv flow; ② 11/32" exhaust orifice with 1.20 Cv flow; ③ 3/64" exhaust orifice with 0.06 Cv flow. ④ 3/32" exhaust orifice with 0.20 Cv flow. ⑤ 10 psi minimum for light oils. ⑥ Max. fluid temp. 180°F for light oil @ 45 SSU. ⑦ Pressure rating for light oil @ 45 SSU. ⑧ 12-24V DC. ⑨ 24-120V AC/DC, 100-240V AC/DC.

ELECTRONICALLY ENHANCED

### 3-Way Specifications (Metric units)

Pipe Size (in)	Orifice Dia. (mm)	Kv Flow Factor (m <sup>3</sup> /h)	Operating Pressure Differential (bar)				Max. Fluid Temp. °C	Brass	Const. Ref.	Agency		Stainless Steel	Const. Ref.	Agency		Wattage DC AC/DC	Approx. Shipping Weight (kgs.)		
			Min.	Max.						UL	UL								
				Air-Inert Gas	Water	Light Oil @ 300 SSU													
<b>General Service - Normally Closed</b>																			
1/8	1.2	0.04 ③	0	21	21	21 ⑦	93 ⑥	8314R031	1	●	8314R037	1	●	1.0 ⑧	1.5 ⑨	0.77			
1/8	2.4	0.13 ④	0	14	14	13 ⑦	93 ⑥	8314R032	1	●	8314R038	1	●			0.77			
1/8	3.2	0.22 ④	0	10	10	7 ⑦	93 ⑥	8314R033	1	●	8314R039	1	●			0.77			
1/4	1.2	0.04 ③	0	21	21	21 ⑦	93 ⑥	8314R034	2	●	8314R068	2	●			0.81			
1/4	2.4	0.13 ④	0	14	14	13 ⑦	93 ⑥	8314R035	2	●	8314R121	2	●			0.81			
1/4	3.2	0.22 ④	0	10	10	7 ⑦	93 ⑥	8314R036	2	●	8314R126	2	●			0.81			
1/4	4.0	0.43 ④	0	5.2	5.2	5.2 ⑦	93 ⑥	8314R130	2	●	8314R230	2	●			0.81			
1/4	5.6	0.60 ④	0	3	3	3 ⑦	93 ⑥	8314R131	2	●	8314R231	2	●			0.81			
1/4	7.1	0.73 ④	0	2	2	2 ⑦	93 ⑥	8314R132	2	●	8314R232	2	●			0.81			
1/4	1.9	0.1	0	16	16	16	82	8320P182	3	●	-	-	-			1.1			
1/4	2.7	0.2	0	10	10	10	82	8320P184	3	●	-	-	-			1.1			
1/4	3.9	0.3	0	5	5	5	82	8320P186	3	●	-	-	-			1.1			
1/4	2.3 ①	0.17 ①	0.3 ④	10	10	7	82	8317P035	4	●	-	-	-			1.2			
1/4	7.1 ②	0.7 ②	0.7	14	14	14	82	8321P001	5	●	-	-	-			1.7			
3/8	7.1 ②	0.7 ②	0.7	14	14	14	82	8321P002	5	●	-	-	-			1.7			
3/8	3.3	2.1	0.7	17	17	-	82	8316P054	6	●	-	-	-			2.2			
1/2	3.3	2.7	0.7	17	17	-	82	8316P064	6	●	-	-	-			2.2			
3/4	17	4.1	0.7	17	17	-	82	8316P074	7	●	-	-	-			2.3			
<b>NAMUR Mount - 3/2 Normally Closed</b>																			
1/4	2.4	0.1	-	10	-	-	82	8320P704	9	●	8320P714	9	●			2	1.5		
<b>General Service - Normally Open</b>																			
1/8	1.2	0.04 ③	0	21	21	21 ⑦	93 ⑥	8314R049	1	●	8314R055	1	●	1.0 ⑧	1.5 ⑨	0.77			
1/8	2.4	0.13 ④	0	12	12	12 ⑦	93 ⑥	8314R050	1	●	8314R056	1	●			0.77			
1/8	3.2	0.22 ④	0	11	11	11 ⑦	93 ⑥	8314R051	1	●	8314R057	1	●			0.77			
1/4	1.2	0.04 ③	0	21	21	21 ⑦	93 ⑥	8314R052	2	●	8314R069	2	●			0.81			
1/4	2.4	0.13 ④	0	12	12	12 ⑦	93 ⑥	8314R053	2	●	8314R122	2	●			0.81			
1/4	3.2	0.22 ④	0	11	11	11 ⑦	93 ⑥	8314R054	2	●	8314R070	2	●			0.81			
1/4	4.0	0.43 ④	0	10	10	10 ⑦	93 ⑥	8314R133	2	●	8314R233	2	●			0.81			
1/4	5.6	0.60 ④	0	6.8	6.8	6.8 ⑦	93 ⑥	8314R134	2	●	8314R234	2	●			0.81			
1/4	7.1	0.73 ④	0	4.5	4.5	4.5 ⑦	93 ⑥	8314R135	2	●	8314R235	2	●			0.81			
1/8	1.2	0.15	0	24	24	24	82	8320P136	8	●	8320P146	8	●			1.1			
1/4	0.8	0.04	0	54	57	57	82	8320P190	3	●	-	-	-			1.1			
1/4	2	0.1	0	14	14	14	82	8320P192	2	●	-	-	-			1.1			
1/4	2.7	0.2	0	10	10	10	82	8320P194	2	●	-	-	-			1.1			
<b>General Service - Universal Operation</b>																			
1/8	1.2	0.04 ③	0	14	14	14 ⑦	93 ⑥	8314R041	1	●	8314R042	1	●			1.0 ⑧	1.5 ⑨	0.77	
1/8	2.4	0.13 ④	0	7	6	4 ⑦	93 ⑥	8314R043	1	●	8314R044	1	●					0.77	
1/8	3.2	0.22 ④	0	5	5	3 ⑦	93 ⑥	8314R045	1	●	8314R040	1	●					0.77	
1/4	1.2	0.04 ③	0	14	14	14 ⑦	93 ⑥	8314R006	2	●	8314R123	2	●					0.81	
1/4	2.4	0.13 ④	0	7	6	4 ⑦	93 ⑥	8314R007	2	●	8314R120	2	●					0.81	
1/4	3.2	0.22 ④	0	5	5	3 ⑦	93 ⑥	8314R008	2	●	8314R124	2	●					0.81	
1/4	4.0	0.43 ④	0	2.5	2.5	2.5 ⑦	93 ⑥	8314R127	2	●	8314R227	2	●	0.81					
1/4	5.6	0.60 ④	0	1.5	1.5	1.5 ⑦	93 ⑥	8314R128	2	●	8314R228	2	●	0.81					
1/4	7.1	0.73 ④	0	0.7	0.7	0.7 ⑦	93 ⑥	8314R129	2	●	8314R229	2	●	0.81					
1/4	2	0.1	0	8	8	8	82	8320P172	3	●	-	-	-	1.1					
1/4	2.7	0.2	0	4	4	4	82	8320P174	3	●	-	-	-	1.1					
1/4	3.9	0.3	0	2	2	2	82	8320P176	3	●	-	-	-	1.1					

● = General Purpose Valve. ① 6.3 mm exhaust orifice with 0.63 Kv flow; ② 8.7 mm exhaust orifice with 1.0 Kv flow; ③ 1.3 mm exhaust orifice with 0.05 Kv flow.  
④ 2.5 mm exhaust orifice with 0.17 Kv flow. ⑤ 0.7 bar minimum for light oils. ⑥ Max. fluid temp. 82°C for light oil @ 45 SSU. ⑦ Pressure rating for light oil @ 45 SSU.  
⑧ 12-24V DC. ⑨ 24-120V AC/DC, 100-240V AC/DC.

ELECTRONICALLY ENHANCED

## 3-Way Optional Features Chart

Pipe Size (in)	Orifice Dia. (in)	Base Catalog Number		Resilient Materials and Suffix Options									Other		Standard Rebuild Kit	
		Brass	Stainless Steel	Silicone Free	NBR	FKM	EPDM	CR	Oxygen Service	PTFE ①	Urethane	Vacuum	Manual Operator ③	Mounting Bracket	Brass	Stainless Steel
1/8	3/64	8314R031	8314R037	SF	●	V ②	-	-	N	-	-	-	MS	MB	323957	323959
1/8	3/64	8314R041	8314R042	SF	●	V ②	-	-	N	-	-	-	MS	MB	323961	323963
1/8	3/64	8314R049	8314R055	SF	●	V ②	-	-	N	-	-	-	MS	MB	323969	323971
1/8	3/32	8314R032	8314R038	SF	●	V ②	-	-	N	-	-	-	MS	MB	323958	323960
1/8	3/32	8314R043	8314R044	SF	●	V ②	-	-	N	-	-	-	MS	MB	323966	323968
1/8	3/32	8314R050	8314R056	SF	●	V ②	-	-	N	-	-	-	MS	MB	323970	323972
1/8	1/8	8314R033	8314R039	SF	●	V ②	-	-	N	-	-	-	MS	MB	323958	323960
1/8	1/8	8314R045	8314R040	SF	●	V ②	-	-	N	-	-	-	MS	MB	323966	323968
1/8	1/8	8314R051	8314R057	SF	●	V ②	-	-	N	-	-	-	MS	MB	323970	323972
1/8	7/16	8320P136	8320P146	⑤	●	V	E	J	N	T	-	-	MO/MS	MB	322715	322718
1/4	1/32	8320P190	-	⑤	●	V	E	J	N	T	-	-	MO/MS	MB	322744	-
1/4	3/64	8314R006	8314R123	SF	●	V ②	-	-	N	-	-	-	MS	MB	323961	323963
1/4	3/64	8314R034	8314R068	SF	●	V ②	-	-	N	-	-	-	MS	MB	323957	323959
1/4	3/64	8314R052	8314R069	SF	●	V ②	-	-	N	-	-	-	MS	MB	323969	323971
1/4	5/64	8320P172	-	⑤	●	V	E	J	N	T	-	-	MO/MS ④	MB	322721	-
1/4	5/64	8320P182	-	⑤	●	V	E	J	N	T	-	-	MO/MS	MB	322722	-
1/4	5/64	8320P192	-	⑤	●	V	E	J	N	T	-	-	MO/MS ④	MB	322723	-
1/4	3/32	8314R007	8314R120	SF	●	V ②	-	-	N	-	-	-	MS	MB	323966	323968
1/4	3/32	8314R035	8314R121	SF	●	V ②	-	-	N	-	-	-	MS	MB	323958	323960
1/4	3/32	8314R053	8314R122	SF	●	V ②	-	-	N	-	-	-	MS	MB	323970	323972
1/4	3/32	8317P035	-	⑤	●	V	-	-	N	-	-	-	-	-	322919	-
1/4	3/32	8320P704	8320P714	⑤	●	V	E	J	N	T	-	-	MO/MS	-	322821	322823
1/4	7/64	8320P174	-	⑤	●	V	E	J	N	T	-	-	MO/MS ④	MB	322721	-
1/4	7/64	8320P184	-	⑤	●	V	E	J	N	T	-	-	MO/MS	MB	322722	-
1/4	7/64	8320P194	-	⑤	●	V	E	J	N	T	-	-	MO/MS ④	MB	322723	-
1/4	1/8	8314R008	8314R124	SF	●	V ②	-	-	N	-	-	-	MS	MB	323966	323968
1/4	1/8	8314R036	8314R126	SF	●	V ②	-	-	N	-	-	-	MS	MB	323958	323960
1/4	1/8	8314R054	8314R070	SF	●	V ②	-	-	N	-	-	-	MS	MB	323970	323972
1/4	5/32	8314R127	8314R227	SF	●	V ②	-	-	N	-	-	-	MS	MB	323966	323968
1/4	5/32	8314R130	8314R230	SF	●	V ②	-	-	N	-	-	-	MS	MB	323958	323960
1/4	5/32	8314R133	8314R233	SF	●	V ②	-	-	N	-	-	-	MS	MB	323970	323972
1/4	5/32	8320P176	-	⑤	●	V	E	J	N	T	-	-	MO/MS ④	MB	322721	-
1/4	5/32	8320P186	-	⑤	●	V	E	J	N	T	-	-	MO/MS	MB	322722	-
1/4	7/32	8314R128	8314R228	SF	●	V ②	-	-	N	-	-	-	MS	MB	323966	323968
1/4	7/32	8314R131	8314R231	SF	●	V ②	-	-	N	-	-	-	MS	MB	323958	323960
1/4	7/32	8314R134	8314R234	SF	●	V ②	-	-	N	-	-	-	MS	MB	323970	323972
1/4	9/32	8314R129	8314R229	SF	●	V ②	-	-	N	-	-	-	MS	MB	323966	323968
1/4	9/32	8314R132	8314R232	SF	●	V ②	-	-	N	-	-	-	MS	MB	323958	323960
1/4	9/32	8314R135	8314R235	SF	●	V ②	-	-	N	-	-	-	MS	MB	323970	323972
1/4	9/32	8321P001	-	⑤	●	V	E	-	-	-	-	-	MO/MS	-	322688	-
3/8	9/32	8321P002	-	⑤	●	V	E	-	-	-	-	-	MO/MS	-	322688	-
3/8	5/8	8316P054	-	⑤	●	V	E	J	N	-	-	-	MO	MB	322690	-
1/2	5/8	8316P064	-	⑤	●	V	E	J	N	-	-	-	MO	MB	322690	-
3/4	11/16	8316P074	-	⑤	●	V	E	J	N	-	-	-	MO	MB	322692	-

● = Standard. Other options may be available. All option combinations may not be available. Please consult your local ASCO contact. ① Pressure rating reduced by 25%.  
② Upper disc is FKM. ③ Not available with PTFE resilient materials. ④ Pressure rating limited to 100 psi (6.9 bar) for MO constructions. ⑤ Consult factory.

**ELECTRONICALLY ENHANCED**

Dimensions: inches (mm)

Const. Ref.		B	C	D	E	F	G	H	I	J
1	in	3.98	3.04	2.09	0.69	1.00	1.19	1.87	1.24	-
	mm	101	77	53	18	25	30	48	32	-
2	in	3.98	3.04	2.09	0.79	1.19	1.56	1.87	1.29	-
	mm	101	77	53	20	30	40	48	33	-
3	in	3.98	3.04	2.00	1.02	2.02	1.69	1.87	1.45	0.44
	mm	101	77	51	26	51	43	48	37	11
4	in	3.98	3.04	2.00	0.57	1.07	2.00	1.87	2.05	-
	mm	101	77	51	14	27	50	48	52	-
5	in	3.98	3.04	2.00	1.00	2.03	1.31	1.87	3.12	1.00
	mm	101	77	51	25	52	33	48	79	25
6	in	3.98	3.04	2.00	2.12	3.77	2.76	1.87	4.29	-
	mm	101	77	51	54	96	70	48	109	-
7	in	3.98	3.04	2.00	2.5	4.19	-	1.87	3.38	-
	mm	101	77	51	64	106	-	48	86	-
8	in	3.98	3.04	2.00	0.67	1.64	1.19	1.87	-	1.81
	mm	101	77	51	17	42	30	48	-	46

Const. Ref. 1, 2

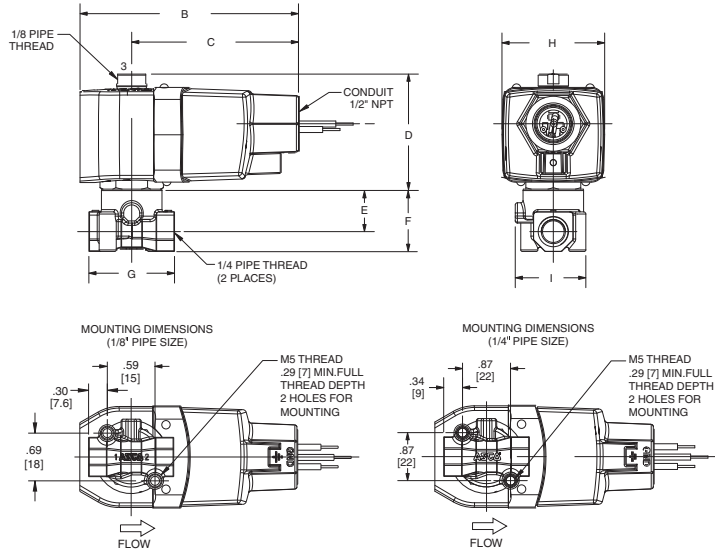

Const. Ref. 3

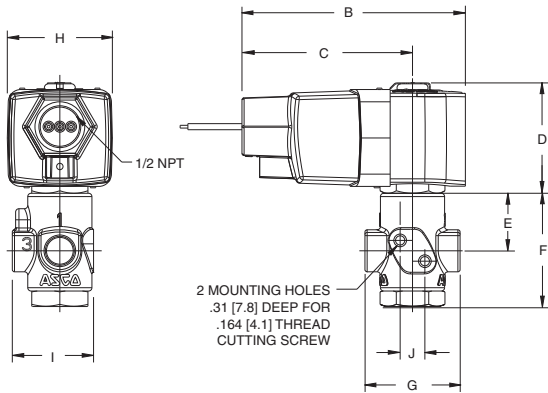

Const. Ref. 4

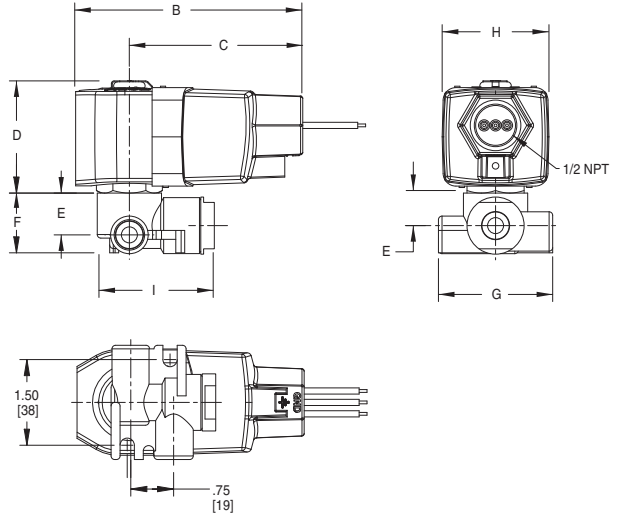

Const. Ref. 5

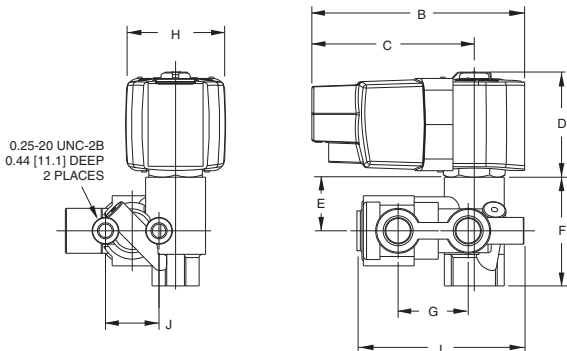

ELECTRONICALLY  
ENHANCED

**Dimensions: inches (mm)**

**Const. Ref. 6**

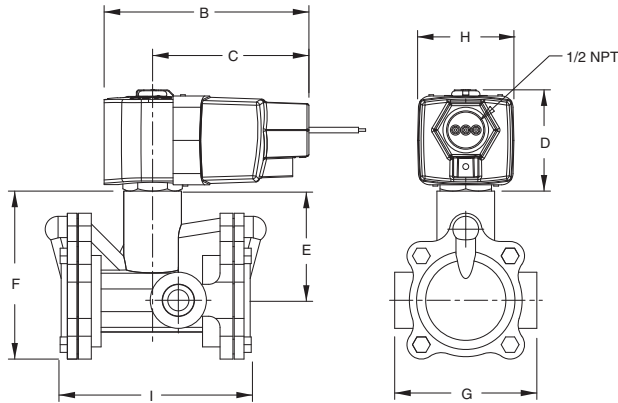

**Const. Ref. 7**

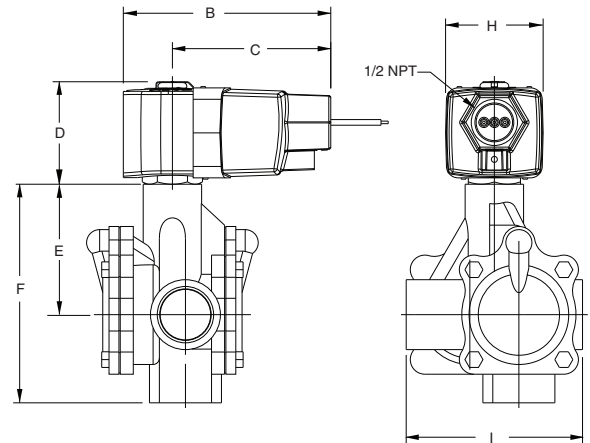

**Const. Ref. 8**

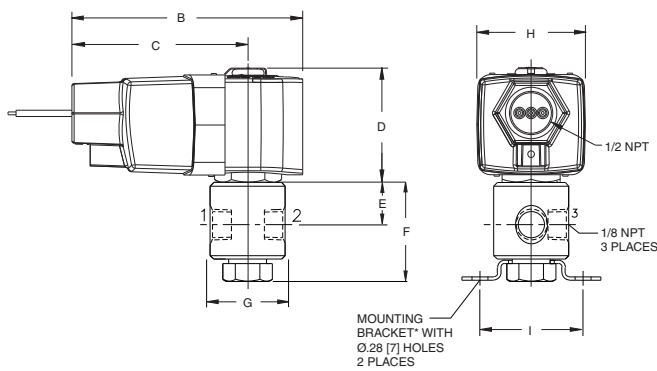

**Const. Ref. 9**

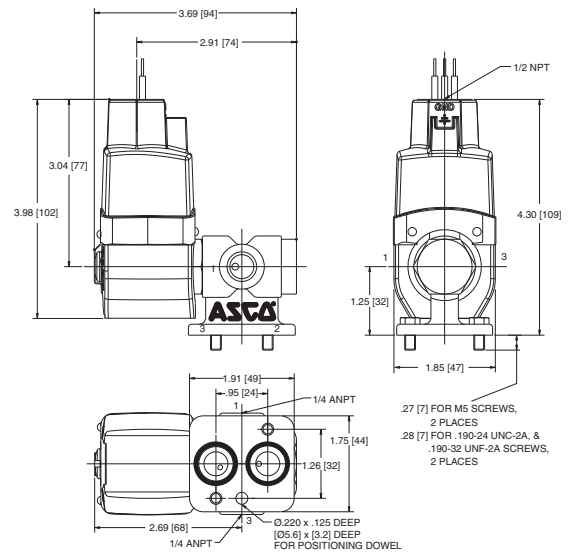

**ELECTRONICALLY  
ENHANCED**

### Electronically Enhanced Solenoids (Next Generation)

All RedHat Next Generation solenoid valves are rated for continuous duty under the operating conditions outlined within this section.

#### Coil Operating Voltage Ranges

All coils are designed for industrial operating voltages and can be used on the following voltage ranges:

Voltage Range	Minimum Voltage	Maximum Voltage
100-240V/50 or 60Hz/DC	85	264
24-120V/50 or 60Hz/DC	20.4	132
12-24/DC only	10.4	26.4

The coils with voltage ranges of 100-240 and 24-99 have three lead wires, 24 inches long (2 red for power input, and one green lead for grounding where necessary). These two versions are not polarity sensitive.

The coil with a voltage range of 12-24/DC has 3 lead wires, one red, one black, and one green. This coil is polarity sensitive. The red lead is the positive, black is the negative, and green is the ground wire. This solenoid is also polarity protected. Reversing the polarity will not damage the coil, but the coil will not function until the correct polarity is applied.

**Note:** The 100-240 voltage range is also suitable for battery charging circuits designed around a 125/DC nominal voltage range.

### Electrical Specifications

2 Watt Electronic Coils	Type
Maximum Ambient Temperature	140°F
Maximum Cycle Rate	1 Operation/ Second
Standard Coil Class of Insulation	H

### Power Consumption

The Next Generation solenoid power rating is 1.0 watt of power for 12-24V DC and 1.5 watts for 24-120V AC/DC, and 100-240V AC/DC.

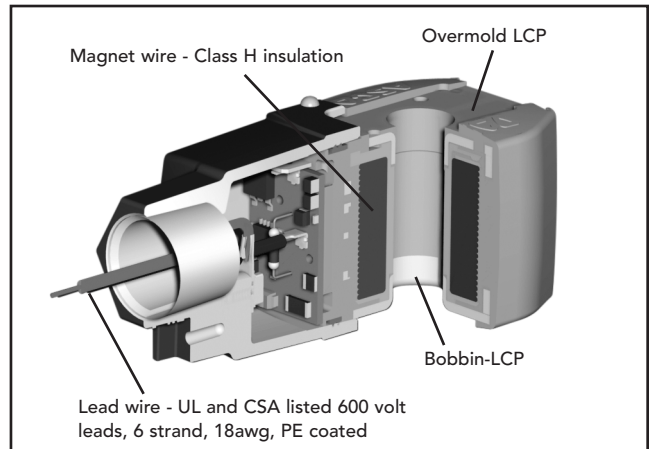



The advanced technology used in the Next Generation coil includes electronic circuitry which may limit the compatibility with certain control system components. The following issues need to be considered when specifying an output card or device to operate the Next Generation coil. An initial inrush current spike is drawn by the Next Generation coil. This inrush spike is 72 msec in duration, which is sufficient time for the core to reach the plugnut. The electrical requirement then drops to the holding value.

**Inrush Current:** The power source, wiring, and output device used need to have surge ratings equal to or greater than the inrush current value (appropriate to the voltage range) specified in the table below.

Inrush Current Rating	
Coil Version	Peak Inrush Current (Amps)
12-24/DC	3.2
24-99/50-60Hz/DC	1.4
100-240/50-60Hz/DC	0.32
Maximum Duration = 72 ms	

**Holding Current:** The power source, wiring, and output device used need to have continuous current ratings equal to or greater than the holding current value (appropriate to the voltage range) specified in the table below.

Holding Current Rating			
Coil Version	Input Voltage	Average Holding Current (Amps)	Average Holding Volt-Amps (VA)
12-24/DC	12	0.230	2.8
	24	0.190	4.5
24-120/50-60Hz/DC	24	0.140	3.4
	120	0.070	8.8
100-240/50-60Hz/DC	100	0.044	4.4
	240	0.032	7.8

### Supervisory/Leakage Currents:

The leakage current is defined as a current that is supplied from an output device when the device is in its off or de-activated state.

The Next Generation coil is suitable for systems using supervisory currents that do not exceed the drop-out currents noted in the table below.

Supervisory/Leakage Current Rating	
Coil Version	Drop-out Current (mA)
12-24/DC	20
24-120/50-60Hz/DC	15
100-240/50-60Hz/DC	7
<b>Important: Supervisory and leakage currents above the drop-out current listed with cause improper operation. Consult your local ASCO Sales office for additional assistance.</b>	

### Solenoid Enclosures

The Next Generation solenoid coil is fully encapsulated using Dupont™ Zenite® Liquid Crystal Polymer resin (LCP). Zenite (LCP) is a thermoplastic polyester resin which exhibits several advantages over other thermoplastics. The advantages include excellent resistance to a wide range of organic solvents and automotive fluids\*, resistance to impact, and long term retention of properties at continuous-use temperatures.

\*Chemical resistance of Zenite LCP may not be suitable for all applications. Zenite LCP is not suitable for caustic solution. *Please consult ASCO for appropriate product solutions.*

Zenite is a registered Trademark of Dupont Co.

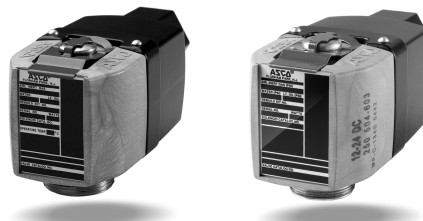

### RedHat Next Generation Solenoids are available as:

General Purpose/Watertight – Intended for indoor and outdoor use and provides protection classifications from NEMA Types 1 through 4X.

Class I, Division 2 for Hazardous Locations/Watertight – Meets Types 1 through 4X and is UL listed and CSA certified for Class I, Division 2, Groups A, B, C, and D and Class II, Division 2, Groups F and G. Operating temperature code T4A (120°C).



### Valve Specifications

#### Maximum Ambient Temperature

The maximum ambient temperature is 140°F (60°C). This limit is based on continuous energization with the maximum fluid temperatures as shown on each catalog page.

#### Response Time

Response time from fully closed to fully open or vice versa depends on valve size, operating mode, fluids, temperature, inlet pressure, and pressure drop. The response times for Next Generation are defined as:

- Small direct acting valves – 10 to 60 msec
- Large direct acting valves – 25 to 90 msec

#### Internally pilot operated valves:

- Small diaphragm types – 20 to 100 msec
- Large diaphragm types – 80 to 150 msec
- Small piston types – 80 to 150 msec
- Large piston types – 105 to 200 msec

### Manual Operators

Manual operators are provided to operate the valves manually when electric actuation is not provided. There are two basic types of manual operators, momentary and maintained. To determine which type of manual operator is available for your valves, please see the Optional Features Chart on the relevant valve catalog page. Once it is determined that the subject valve can accommodate a manual operator, the chart below will tell you the type of manual operator. The chart also references the relevant cutaway illustration.

Series Number	Const. Ref.	Manual Operator Suffix	Manual Operator Type	Illustration Number
8030	8	MO	Maintained	3
8210	4, 7, 10, 11, 12	MO	Maintained	2
8262	1	MS	Maintained	6
8263	1	MS	Maintained	6
8314	1	MS	Maintained	6
8316	5, 6	MO	Maintained	2
8320	2	MO	Momentary	1
8320	2	MS	Maintained	6
8321	4	MO	Momentary	1
8321	4	MS	Maintained	3
8344	1, 3, 4	MO	Maintained	2
8345	2	MO	Maintained	5

Operation on liquids has relatively little effect on small direct acting valves, however, response times of large direct acting and internally piloted valves may be lengthened by 50% to 100%.

### Cutaway Illustrations

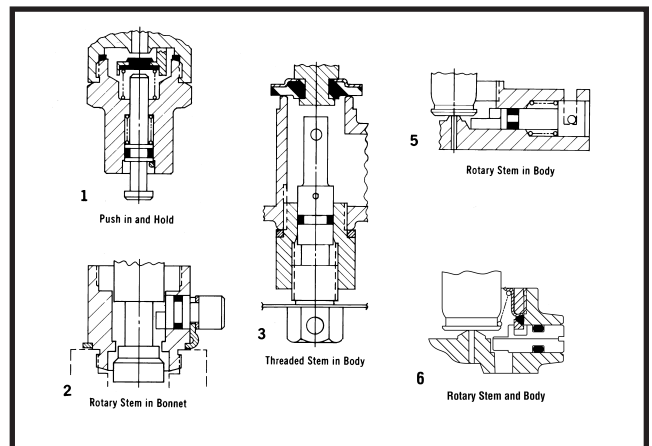

Valve Parts in Contact with Fluids						
Series	Body	Seals and Discs	Disc Holder	Core Guide	Springs	Shading Coil
8030	Brass	NBR	-	-	302 Stainless Steel	Copper
8210	304 Stainless Steel	NBR	-	-	302 Stainless Steel	Silver
	Brass	NBR	①	-	302 Stainless Steel	Copper
8223	304 Stainless Steel	PTFE, NBR	-	-	302 Stainless Steel	Silver
	Brass	NBR, PA, PTFE	-	-	302 Stainless Steel	Copper
8262	304 Stainless Steel	NBR	-	-	302 Stainless Steel	Silver
8262P261	304 Stainless Steel	UR	-	-	302 Stainless Steel	Silver
8262R099	304 Stainless Steel	UR	-	-	302 Stainless Steel	Silver
8262R107	304 Stainless Steel	UR	-	-	302 Stainless Steel	Silver
8262R175	304 Stainless Steel	UR	-	-	302 Stainless Steel	Silver
8262R178	304 Stainless Steel	UR	-	-	302 Stainless Steel	Silver
8262	Brass	NBR	-	-	302 Stainless Steel	Copper
8262R077	Brass	LT NBR	-	-	Inconel	Copper
8262R078	Brass	LT NBR	-	POM	Inconel	Copper
8263	304 Stainless Steel	NBR	-	-	302 Stainless Steel	Silver
8263	Brass	NBR	-	-	302 Stainless Steel	Copper
8314	304 Stainless Steel	NBR, FKM	-	POM	302 Stainless Steel	Silver
8314	Brass	NBR, FKM	-	POM	302 Stainless Steel	Copper
8316	Brass	NBR	POM	POM	302, 17-7PH Stainless Steels	Copper
8317	Brass	NBR, FKM, CR	-	POM	302, 17-7PH Stainless Steels	Copper
8320	303 Stainless Steel	NBR	POM	POM	302 Stainless Steel	Silver
8320	Brass	NBR	POM	POM	302 Stainless Steel	Copper
8321	Brass	NBR	POM	POM	302 Stainless Steel	Copper
8344	Brass	NBR	POM	POM	302, 17-7PH Stainless Steels	Copper
8345	Brass	NBR, PA	-	POM	302 Stainless Steel	Copper
8551	316 Stainless Steel	NBR, PA	-	POM	302 Stainless Steel	Copper
8551	Anodized Aluminum	NBR, PA	-	POM	302 Stainless Steel	Copper

Note: All core tubes are 305 stainless steel and all cores and plugnuts are 430F stainless steel. ① 8210P033, 8210P034, and 8210P035 with PA Disc Holder