

Features

- Designed for high flow piloting with no minimum operating pressure required; e.g. power plants, refineries, chemical processing
- Balanced Poppet construction for high flow at minimum power levels
- PTFE rider rings and graphite-filled seals reduce friction and eliminate sticking to provide exceptional service life
- 316 Stainless Steel construction for highly corrosive atmospheres
- Available with manual reset (See *Special Service Section*)
- Low power construction available for applications with power limitations

Construction

	Standard Power		Low Power	
	Brass	316 Stainless Steel	Brass	316 Stainless Steel
Core Tube	Stainless Steel		304 Stainless Steel	
Stem and Insert	303 Stainless Steel			
Core and Plugnut	430F Stainless Steel			
O-ring Holder	430F Stainless Steel			
Springs	302 Stainless Steel			
Seals and Discs	NBR	FKM	FKM	
	VMQ (Low-Temp. Construction)		FVMQ (Low-Temp. Construction)	
Rider Ring	PTFE			

Electrical

Standard Coil and Class of Insulation	Watt Rating and Power Consumption				Spare Coil Part Number			
	DC Watts	AC			General Purpose		Explosionproof	
		Watts	VA Holding	VA Inrush	AC	DC	AC	DC
F	11.6	12	12	12	276000	238710	276002	238714
F	2.0	-	-	-	-	501695	-	501696
H	2.7	-	-	-	-	501694	-	440162

Standard Voltages: 24/50-60, 120/50-60, 240/50-60, and 480/50-60, or 6, 12, 24, 120, and 240 DC.

IMPORTANT: Supervisory and leakage current above the drop out current listed will cause improper operation. Consult your local ASCO sales office for additional assistance.

Low Power Description	Wattage	Voltage (DC)	Min. Pull In (mA)	Drop Out (mA)	Coil Resistance @68°F (20°C) (ohms)
Standard Ambient Version	2.0W	12V	120	13.6	3500
		24V	62	7	6800
		48V	31	3.5	13450
High Ambient Version	2.7W	12V	133	13.6	3150
		24V	72	7	5800
		48V	35	3.5	12050

Solenoid Enclosures

Standard:

For Brass Valves: Standard Solenoid enclosure is Types, 1, 2, 3, 3S, 4, and 4X.

For 316 Stainless Steel valves: Standard Solenoid enclosure is Explosionproof and Watertight Types 3, 3S, 4, 4X, 6, and 6P.

Optional: Explosionproof and Watertight, Types 3, 3S, 4, 4X, 6, 6P, 7, and 9. (To order, add prefix "EF" or, for Explosionproof Stainless Steel trim and hub on Brass-Bodied valves, add "EV" to catalog number. EV not available for 2.0W and 2.7W constructions)

See *Optional Features Section* for other available options.

SIL (Safety Integrity Level) Information:*

- PFD (Probability of Failure on Demand) $<4 \times 10^{-7}$ at a confidence factor of 95%.
- SFF (Safe Failure Fraction) according to IEC 61508-2 Table A1 is ≥ 0.99 .

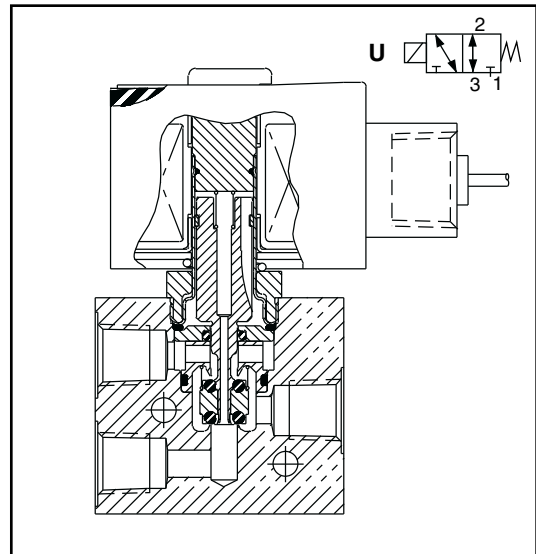

Nominal Ambient Temp. Ranges

8327G041 & 042: -4°F to 131°F (-20°C to 55°C)

8327G051 & 052: -40°F to 131°F (-40°C to 55°C)

8327H301 & 302: Class F: -4°F to 140°F (-20°C to 60°C)
 Class H: -4°F to 194°F (-20°C to 90°C)

8327H311 & 312: -58°F to 140°F (-50°C to 60°C)

Refer to *Engineering Section* for details.

Approvals

CSA certified. UL listed General Purpose Valves. (Excludes low-power General Purpose coil constructions)

Explosionproof low-power constructions carry UL & CSA solenoid only approvals.

Meets applicable CE directives. (General Purpose versions only)

SIL 3 capable per IEC 61508. Third party certification by Exida.

3-WAY

Specifications (English units)

Pipe Size (in)	Orifice Size (in)	Cv Flow (Kv = m ³ /hr)		Maximum Operating Pressure Differential psi (bar)			Max. Fluid Temp. °F (°C)	Brass Body Catalog Number	316 Stainless Steel Body Catalog Number	Const. Ref.	Watt Rating/Class of Coil Insulation	
		Ports 1-2	Ports 2-3	Air-Inert Gas	Water	Light Oil @ 300 SSU					AC	DC
UNIVERSAL OPERATION (Pressure at any port)												
1/4	1/4	0.49 (0.42)	0.56 (0.48)	150 (10.3)	150 (10.3)	150 (10.3)	176 (80)	8327G041	-	1	12.0/F	11.6/F
1/4	1/4	0.49 (0.42)	0.56 (0.48)	150 (10.3)	150 (10.3)	150 (10.3)	248 (120)	-	EV8327G042	1	12.0/F	11.6/F
UNIVERSAL LOW-TEMPERATURE OPERATION (Pressure at any port)												
1/4	1/4	0.49 (0.42)	0.56 (0.48)	150 (10.3)	-	-	131 (55)	8327G051	-	1	12.0/F	11.6/F
1/4	1/4	0.49 (0.42)	0.56 (0.48)	150 (10.3)	-	-	131 (55)	-	EV8327G052	1	12.0/F	11.6/F
UNIVERSAL LOW-POWER OPERATION (Pressure at any port)												
1/4	1/4	0.49 (0.42)	0.56 (0.48)	150 (10.3)	-	-	140 (60)	8327H311	8327H312	2	-	2.0/F
1/4	1/4	0.49 (0.42)	0.56 (0.48)	150 (10.3)	150 (10.3)	150 (10.3)	140 (60)	8327H301	8327H302	2	-	2.0/F
1/4	1/4	0.49 (0.42)	0.56 (0.48)	150 (10.3)	150 (10.3)	150 (10.3)	194 (90)	HT8327H301	HT8327H302	2	-	2.7/H

Dimensions: inches (mm)

3-WAY

Flow Diagrams

OPERATION	DE-ENERGIZED	ENERGIZED
NORMALLY CLOSED PRESSURE AT 3		
NORMALLY OPEN PRESSURE AT 1		
UNIVERSAL PRESSURE AT ANY PORT		

Const. Ref. 1

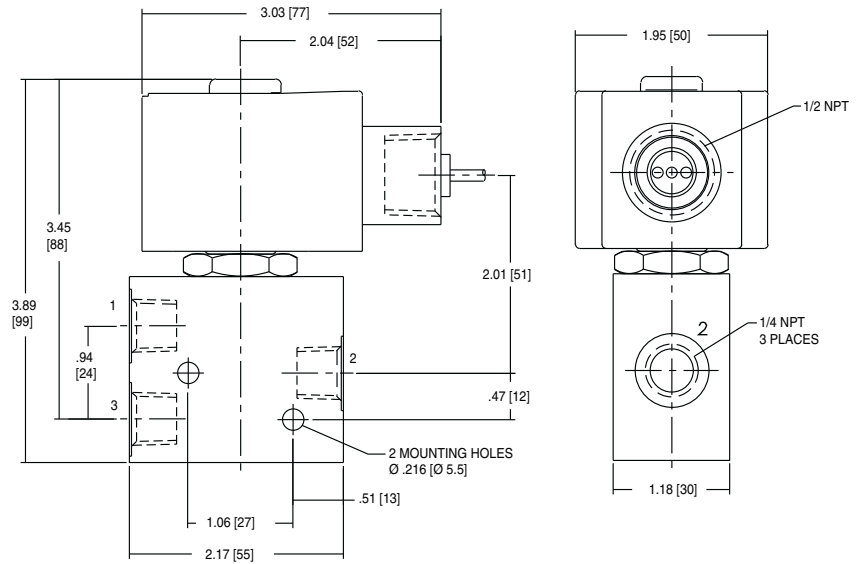

Const. Ref. 2

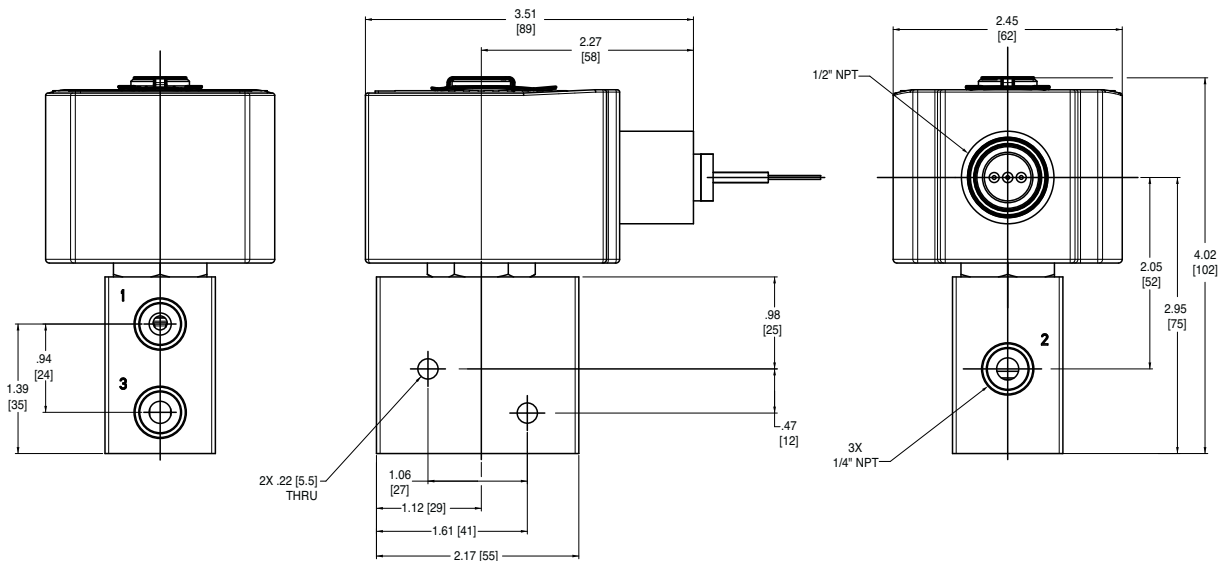

IMPORTANT: Valves may be mounted in any position.