

FEATURES

- Lever type Manual Reset function which means that the valve has to be energized as well as manually operated before it stays in the "latched" position
- The No Voltage Release (NVR) function will make sure that the valve trips when de-energized
- The solenoid valves are recommended for 4/2 way pilot applications with high flow and wide pressure ranges
- Brass bodied valves with stainless steel internal parts
- The use of first class materials and thorough valves testing ensure a high reliability and a long service life
- The solenoid valves satisfy all relevant EC Directives

GENERAL

Differential pressure 0 - 17 bar [1 bar = 100kPa]
Maximum viscosity 65cST (mm²/s)
Response times 75 - 100 ms

fluids (*)	temperature range	seal material (*)
air, inert gas	- 30°C to + 70°C	NBR (nitrile)

MATERIALS IN CONTACT WITH FLUID

(*) Ensure that the compatibility of the fluids in contact with the materials is verified

	Brass body
Body	Brass
Core tube	Stainless steel
Core and plugnut	Stainless steel
Springs	Stainless steel
Seals	NBR
Disc and poppets	PTFE
Seat	PTFE
Slide	PA
Slide cups	FPM

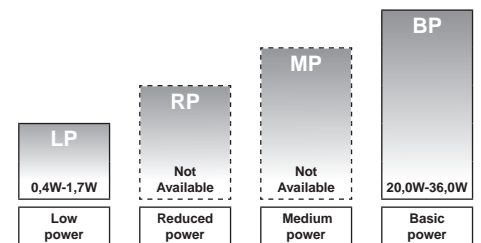
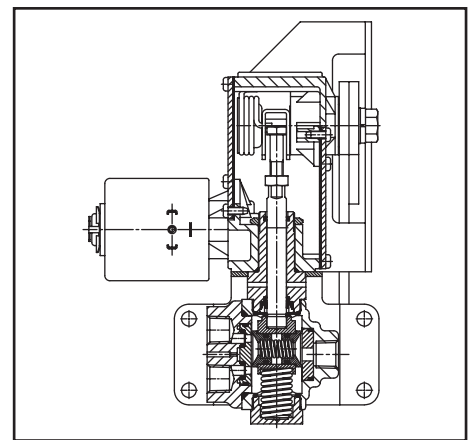
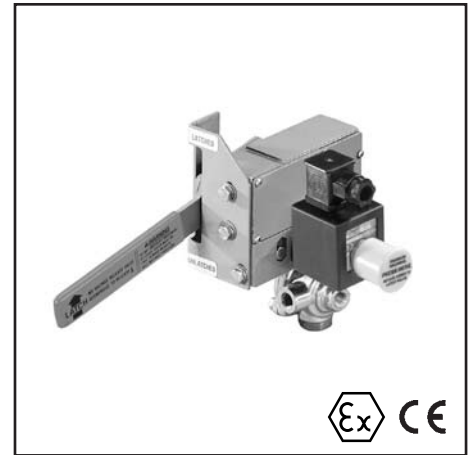

POWER LEVELS - cold electrical holding values (watt)

SPECIFICATIONS

pipe size	orifice size	flow coefficient Kv		operating pressure differential (bar)		power level	prefix optional solenoids					basic catalogue number		
							min.	max. (PS)	NEMA 7&9	ATEX / IECEx			IP65	
										air (*)	Ex d			Ex e mb
Npt	(mm)	(m ³ /h)	(l/min)			~/=	~/=	EF	NF	EM	PV	IS	SC	brass
4/2 - Single solenoid, manual reset (NVR)														
1/4	4,8	0,7	9,9	0	17,0	LP	-	-	●	-	○	●	●	B408A406
3/8	4,8	0,7	9,9	0	17,0	LP	-	-	●	-	○	●	●	B408A407
1/4	4,8	0,7	9,9	0	17,0	BP	-	●	●	-	-	●	●	B408B006
3/8	4,8	0,7	9,9	0	17,0	BP	-	●	●	-	-	●	●	B408A007

● Available feature ○ Available feature in DC only - Not available

All leaflets are available on: www.asconumatics.eu

PREFIX TABLE

prefix							description	power level			
1	2	3	4	5	6	7		LP	RP	MP	BP
E	F						Explosionproof - NEMA 7, 9 - Zinc plated steel conduit	-	-	-	-
E	V						Explosionproof - NEMA 7, 9 - 316 SS conduit	-	-	-	-
E	M						Waterproof IP67 - Metal enclosure (EN/IEC 60079-7+18, 61241-1)*	●	-	-	-
		E	T				Threaded conduit/hole (M20 x 1,5)	●	-	-	●
I	S		S	C			Intrinsically safe with SC coil (EN/IEC 60079-11+26, 61241-11)*	○	-	-	-
N	F						Flameproof - Aluminium (EN/IEC 60079-1, 60079-31)*	-	-	-	●
P	V						Encapsulated epoxy moulded (EN/IEC 60079-18, 61241-18)*	-	-	-	-
S	C						Solenoid with spade plug connector (EN/IEC 60730)	●	-	-	●
W	P						Waterproof IP67 - Metal enclosure	●	-	-	●
W	P			I	S		I.S. with Metal IP67 enclosure (EN/IEC 60079-11+26, 61241-11)*	○	-	-	-
W	S						Waterproof IP67 - 316 SS enclosure	●	-	-	●
W	S	E	M				Waterproof IP67 - 316 SS enclosure (EN/IEC 60079-7+18, 61241-1)*	●	-	-	-
W	S			I	S		I.S. with 316 SS IP67 enclosure (EN/IEC 60079-11+26, 61241-11)*	○	-	-	-
W	S	N	F				Flameproof - 316 SS (EN/IEC 60079-1, 60079-31)*	-	-	-	●
		T					Threaded conduit (1/2" NPT)	●	-	-	●
				H	C		Class H - Battery charging circuit	-	-	-	●
				H	T		Class H - High temperature	-	-	-	●
						X	Other special constructions	●	-	-	●

SUFFIX TABLE

suffix					description	power level			
1	2	3	4	5		LP	RP	MP	BP
E					EPDM (ethylene-propylene)	-	-	-	-
J					CR (chloroprene)	-	-	-	-
N					Oxygen service (CR (chloroprene))	-	-	-	-
N	V				FPM (fluoroelastomer) and parts cleaned for oxygen service	-	-	-	-
V					FPM (fluoroelastomer)	-	-	-	-
	C	O			Epoxy coating on all external surfaces	●	-	-	●
	M	B			Mounting bracket	-	-	-	-
		P			Dry gas, non-lubricated air construction	-	-	-	-
		Q			Long life, quiet operation construction	-	-	-	-
			M	O	Push type manual operator	-	-	-	-
			M	S	Screw type manual operator	-	-	-	-
				M	Metering device	-	-	-	-

- Available feature
- Available feature in DC only
- ☆ Available feature in AC only
- Not available
- * ATEX solenoids are also approved according to EN 13463-1 (non electrical valves)

PRODUCT SELECTION GUIDE

STEP 1

Select basic catalogue number, including pipe thread identification letter. Refer to the specifications table on page 1 or 2.

Example: B408B006

STEP 2

Select prefix (combination). Refer to the specifications table on page 1 and the prefix table on page 2, respect the indicated power level.

Example: EMET

STEP 3

Select suffix (combination) if required. Refer to the suffix table on page 2, respect the indicated power level.

Example: CO

STEP 4

Select voltage. Refer to standard voltages on page 3.

Example: 230V / 50Hz

STEP 5

Final catalogue / ordering number.

Example:

EMET B408B006 230V / 50 Hz

OPTIONS & ACCESSORIES

catalogue number	spare parts kit no. ⁽¹⁾		mounting bracket no. ⁽²⁾
	~	=	
B408B006	C304159	C304211	-
B408A007	C304159	C304211	-
B408A406	C308588	C308588	-
B408A407	C308588	C308588	-

- ⁽¹⁾ Standard prefixes/suffixes are also applicable to kits
- ⁽²⁾ Integrated mounting bracket

ORDERING EXAMPLES VALVES:

SC	B	408B006	NV	24V / DC
WS	B	408A406	CO	24V / DC
WP	B	408B006	NV	24V / DC

prefix — pipe thread — basic number — voltage — suffix

ORDERING EXAMPLES KITS:

		C304159 ⁽³⁾
WS	C304211	
WS	C304159	

prefix — basic number

- ⁽²⁾ Basic kit number applies to SC coil construction

EXPLANATION OF TEMPERATURE RANGES OF SOLENOID VALVES

Valve temperature range	The valve temperature range (TS) is determined by the selected seal material, the temperature range for proper operation of the valve and sometimes by the fluid (e.g. steam)
Operator ambient temperature range	The operator ambient temperature range is determined by the selected power level and the safety code
Total temperature range	The temperature range of the complete solenoid valve is determined by the limitations of both temperature ranges above

ELECTRICAL CHARACTERISTICS

Coil insulation class	F (H in DC)
Connector	Spade plug
Connector specification	ISO 4400 (cable Ø 6-10 mm)
Electrical safety	IEC 335
Standard voltages:	DC (=) 24V - 48V; Allowable voltage variation +10%, -15%
	AC (~) 24V - 48V - 115V - 230V/50Hz; Other voltages are available on request

prefix option	power ratings				operator ambient temperature range (TS) (C°) ⁽¹⁾	safety code	electrical enclosure protection (EN 60529)	replacement coil / kit		type ⁽²⁾
	inrush ~	holding ~	hot/cold =					~	=	
	(VA)	(VA)	(W)	(W)				230V/50 Hz	24V/DC	
Basic power (BP)										
SC	96	43	20	16/23	-40 to +75	EN 60730	IP65, moulded	400-525-217	400-625-242	01
WP/WS	96	43	20	16/23	-40 to +75	EN 60730	IP67, steel/SS	400-505-217	400-605-242	02
NF/WSNF	96	43	20	16/23	-60 to +40/60	II2G Ex d IIC Gb T4, II2D Ex t IIIC Db	IP67, alu./SS	400-505-217	400-605-242	-
Low Power (LP)										
SC	1,2	1,2	1,2	1,3/1,3	-40 to +75	EN 60730	IP65, moulded	400-929-097	400-929-042	03
WP/WS	1,2	1,2	1,2	1,3/1,3	-40 to +75	EN 60730	IP67, steel/SS	400-930-097	400-930-042	04
EM/WSEM	1,2	1,2	1,2	1,3/1,3	-40 to +60	II2G Ex e mb II T6, II2D Ex tD A21	IP67, steel/SS	400-930-097	400-930-042	04
ISSC	-	-	-	0,4/0,4	-40 to +60	II2G Ex ia IIC T6, II2D Ex iaD 21	IP65, moulded	-	123-256-001	03
WPIS/WSIS	-	-	-	0,4/0,4	-40 to +60	II2G Ex ia IIC T6, II2D Ex iaD 21	IP67, steel/SS	-	109-496-003	04

⁽¹⁾ Temperature range can be limited by sealings

⁽³⁾ Multiple coil kits are available under ATEX/IECEX, contact us

⁽²⁾ Refer to the dimensional drawings on page 4

- Not available

ADDITIONAL OPTIONS

- Other pipe threads are available on request
- Compliance with "UL", "CSA" and other local approvals available on request
- 1/2" NPT (prefix "T") and M20 x 1,5 (prefix "ET") conduits (aluminium or 316 SS) available for steel solenoid housing
- Special moulded-in solid state components for peak voltage suppression and/or rectification (four diode bridge)

INSTALLATION

- The solenoid valves have to be mounted vertically and in an upright position for best performance
- Multi language installation/maintenance instructions are included with each valve
- Threaded pipe connection identifier is B = NPT (ANSI 1.20.3)
- Ex e mb (prefix "EM") execution: solenoid enclosure has a cable gland with integral strain relief for cables with an o.d. from 7 to 12 mm and is provided with an internal and external connection facility for an earthing or bonding conductor

All leaflets are available on: www.asconumatics.eu

DIMENSIONS (mm), WEIGHT (kg)



TYPE 01:
Epoxy moulded
SC: IEC 335 / ISO 4400

B408B006 / A007



TYPE 02:
Metal, epoxy coated / AISI 316 SS
WP / WS: IEC 335

B408B006 / A007

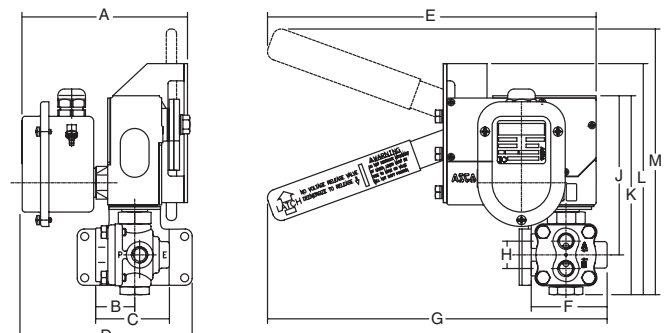
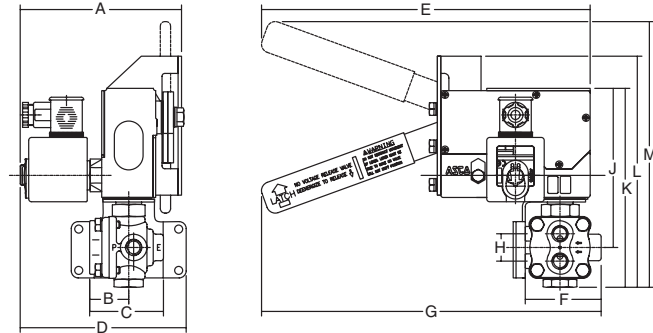

TYPE 03:
Epoxy moulded
SC: IEC 335 / ISO 4400
ISSC: EN/IEC 60079-11+26, 61241-11

B408A406 / A407



TYPE 04:
Metal, epoxy coated / AISI 316 SS
WP / WS: IEC 335
EM / WSEM: EN/IEC 60079-7+18, 61241-1
WPIS / WSIS: EN/IEC 60079-11+26, 61241-11

B408A406 / A407

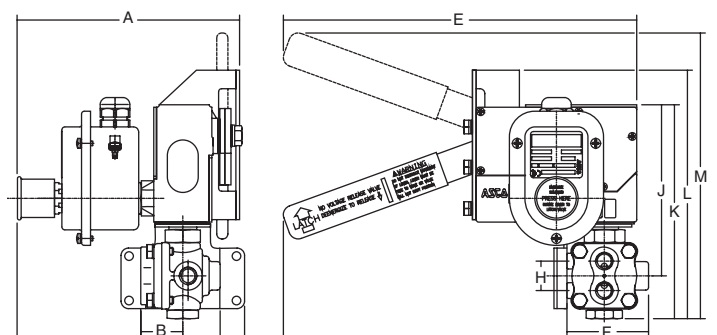
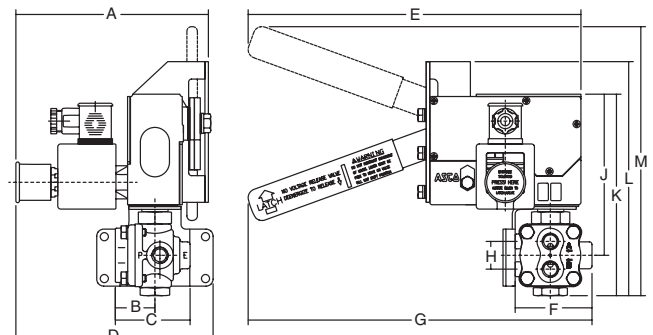

type	prefix option	power level	A	B	C	D	E	F	G	H	J	K	L	M	weight
01	SC	BP	140	34	64	144	286	66	296	24	139	173	201	231	2,75 kg
02	WP, WS	BP	144	34	64	148	286	66	296	24	139	173	201	231	2,75 kg
03	SC, ISSC	LP	166	34	64	170	286	66	296	24	139	173	201	231	2,75 kg
04	WP, WS, EM, WSEM	LP	180	34	64	184	286	66	296	24	139	173	201	231	2,75 kg

All leaflets are available on: www.asconumatics.eu