



**Fluid Control Solutions for your
Analytical & Medical applications**

**Market-leading fluid control solutions
addressing the world's most critical needs**





青岛秉诚自动化设备有限公司
地址：中国·青岛市重庆南路99号海尔云街甲3号楼7F

服务热线：4006-918-365
网址：<http://www.ivalve.cc>

传真：(86-532)585-10-365
Email：sales@bechinas.com

Table of Contents:

Introduction

Emerson – your Partner in Analytical and Medical Technology	5
ISO Class 8 equivalent Cleanroom Manufacturing	6
Global Infrastructure	7
Applications	8
Medical Technologies	8
Analytical Technologies	9
Emerson’s Solutions Approach	10
Rapid Engineered Solutions	10
Capabilities	11
Fluid Isolation Valves	12
General Service Valves	14
Proportional Valves	16

Datasheets

Fluid Isolation Valves	21
General Service Valves	77
Proportional Valves	135
Manifolds & Accessories	153

Engineering Information

Solenoid Valves – Information & Terminology	169
Chemical Resistance Guide	173
Conversion Tables	177

Emerson – your Partner in Analytical and Medical Technology



Emerson fluid control solutions help customers maximize instrument efficiencies and optimize their Medical & Analytical applications. Our global scale increases speed to market and shapes how we work with customers. Our deep expertise across applications rapidly transforms ideas into measurable outcomes.

We offer miniature Isolation, Pinch, Proportional, and General Service valves to reliably control gases and liquids. To adhere to the quality and reliability standards necessary for today's applications, all valves are 100% factory tested before being shipped to our valued customers.

Our miniature valves can be found throughout the world in applications such as:

- Bioinstrumentation
- Chromatography
- Clinical Diagnostics
- Dental Equipment
- Hemodialysis
- Industrial Analyzers
- Oxygen Therapy
- Patient Monitoring
- Sterilizers
- Surgical Instruments
- Therapy Equipment
- Ventilators

In addition to our comprehensive catalog product offering, we have the expertise to create customized assemblies that provide the precise solution to meet your fluid control needs. Whether you need a minor modification of a catalog product or a complete flow control solution, our trained sales and engineering teams are ready to assist.



ISO Class 8 equivalent Cleanroom Manufacturing

Emerson takes great care to minimize contamination during manufacturing. That's why Emerson's miniature valves are assembled in ISO Class 8 equivalent cleanrooms.

Key Points:

- State-of-the-art ISO Class 8 equivalent cleanrooms with positive pressure HEPA air filtration systems monitored daily
- Staff members enter and leave through airlocks with air shower stage and wear protective hair nets, finger cots, shoe covers, lab coats, and masks (when required) to reduce contamination potential
- The environment is controlled for humidity and temperature
- Valve components are ultrasonically cleaned to remove any contaminate prior to assembly

Global Infrastructure

With 8,000 employees worldwide supporting our Fluid Control & pneumatics product lines, working from manufacturing and sales offices in over 45 countries, Emerson is ready to handle your most demanding design challenges. Whether you need a minor modification of a catalog product or a complete flow control system, our trained sales and engineering staff are ready to assist.

Fluid Control & Pneumatics

With manufacturing facilities in Europe, America and Asia you can be assured that you will get the right product, when you need it.

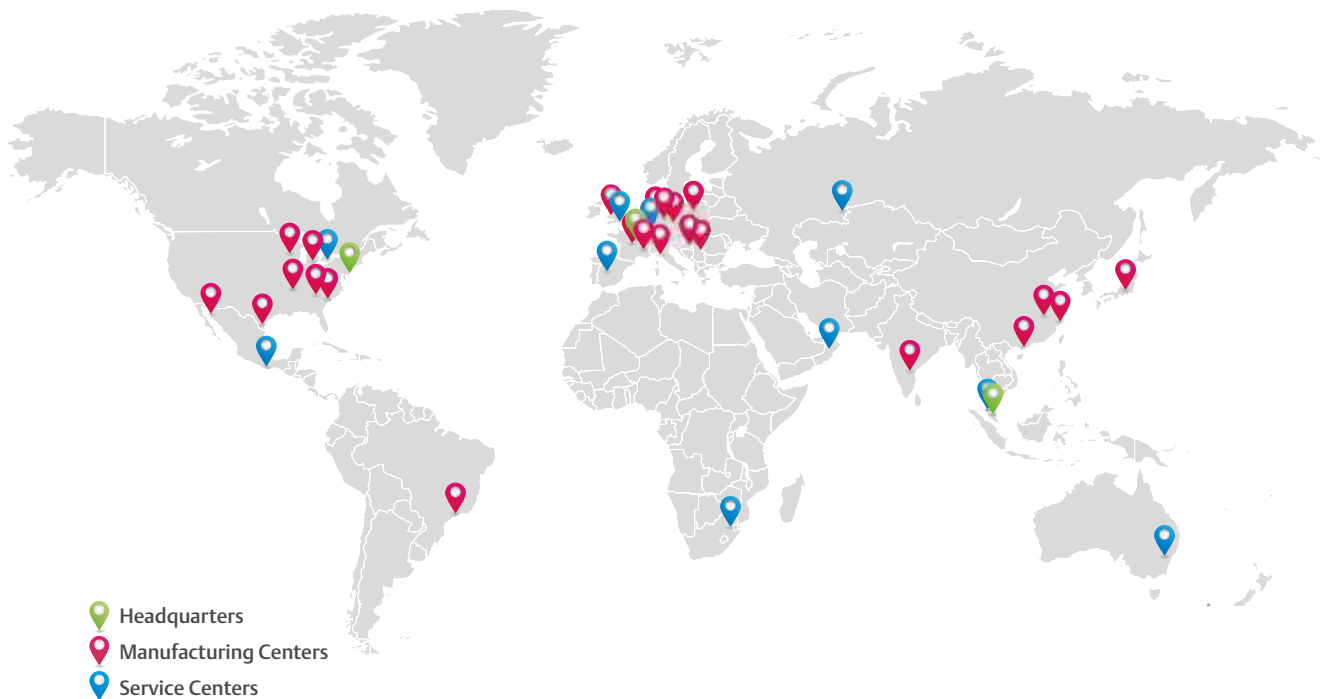

Medical Technologies



Focus on safety for patients

We specialize in developing fluid handling solutions for medical devices and processes used to monitor and/or treat diseases or medical conditions, with the intent to improve quality of life. Our design engineers have decades of experience in creating solutions that support our customers exact requirements.

The ASCO miniature valve product line is ideally suited for use in the following medical applications:

- Dental Delivery Systems
- Oxygen Therapy
- Patient Monitoring
- Therapeutic Support Surfaces
- Ventilators
- Hemodialysis
- Chemical Sterilizers
- Surgical Instruments



As samples are precious and results are fundamental for diagnosis, precise dosage and minimal external influence are central requirements. The special design of our isolation valves reduces heat transfer to thermally sensitive media and reduces unnecessary waste of costly reagents.

Analytical Technologies

Highest precision and functionality – especially suitable for aggressive fluids

Analytical technologies involve a scientific instrument used to analyze a chemical species or a patient sample. Typically, analytical applications require resistance to aggressive fluids, a low internal volume, and an easy-to-flush internal cavity to minimize cross-contamination. Power consumption of the miniature product line is also minimized to reduce heat transfer to expensive reagents and biological fluids.

The miniature valve product line is ideally suited for use in the following analytical applications:

- Clinical Chemistry
- Hematology
- Sample Preparation
- DNA Sequencing
- Immunoassay
- Chromatography
- Molecular Diagnostics
- Industrial Analyzers

Emerson's Solutions Approach: Rapid Engineered Solutions

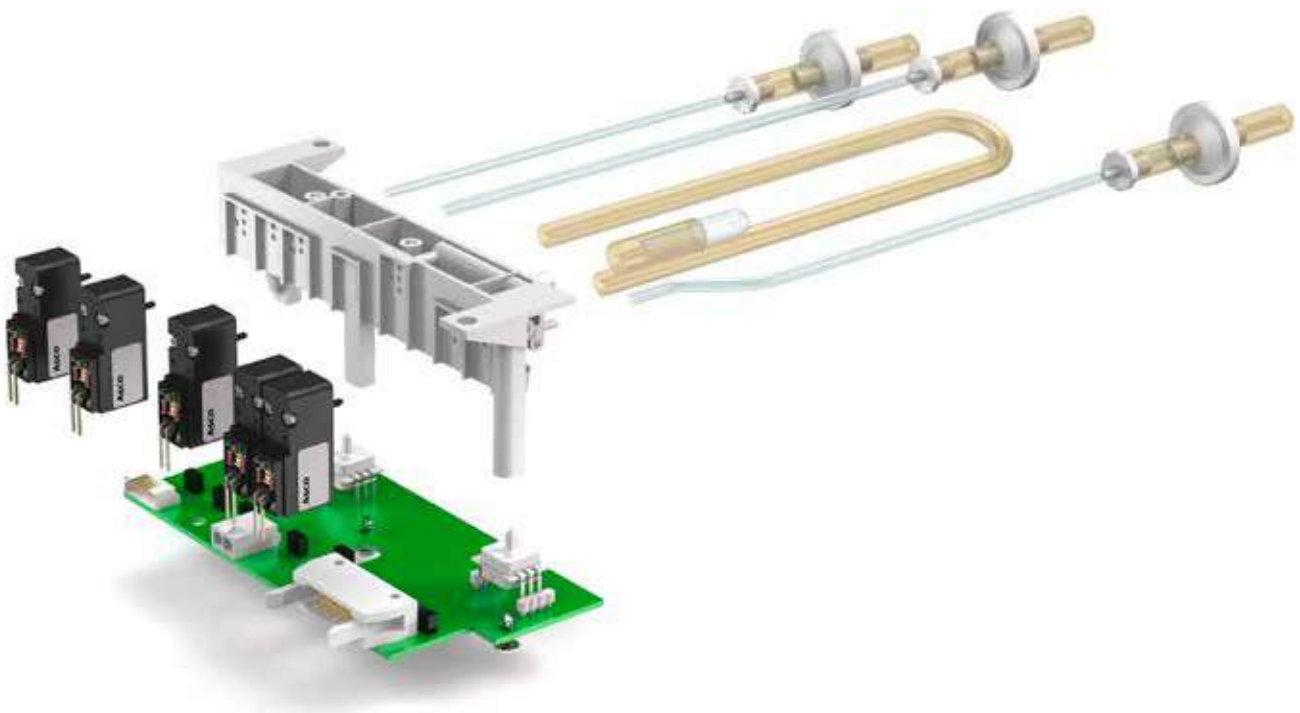

The Analytical and Medical marketplace is driven mainly by customization of products in order to meet varying customer instrumentation demands. The ability to quickly customize a valve product, or provide a solution, is increasingly demanded by OEM engineers. Instrumentation development times are being reduced, and as a result instrument complexity is being consolidated into modular components to accelerate speed-to-market.

Rapid Engineered Solutions are focused on miniature valve products that fulfill the needs of the analytical and medical instrument markets. Backed by the group's prototype labs, valves and assemblies are designed for quick and efficient manufacturing. Our local technical support teams provide the personal support you need during your development processes.

Customized Solutions

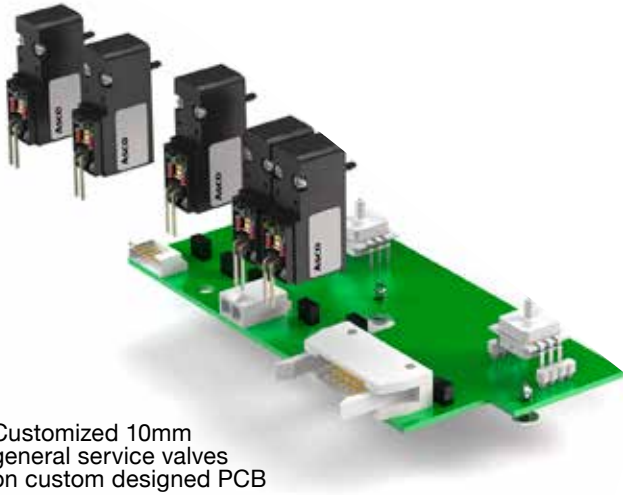

Customized 10mm general service valves on custom designed PCB



Plastic manifold for stability and mounting into the device based on customer needs (e.g. injection molded or machined parts)



Tubings and fittings for direct connection to specified fluidic path within the medical device

Capabilities

Our technical expertise and product customization capabilities enable fast turnaround on complex, high-performing fluidic systems. Our experts understand how to simplify your fluidic path designs, which in turn maximizes performance efficiencies and reduces your manufacturing and operating costs. From concept to production, we deliver your complete manifold assembly, including valves, electrical terminations, pins and housings – anything needed to create the right solution.

Fluid Isolation Valves

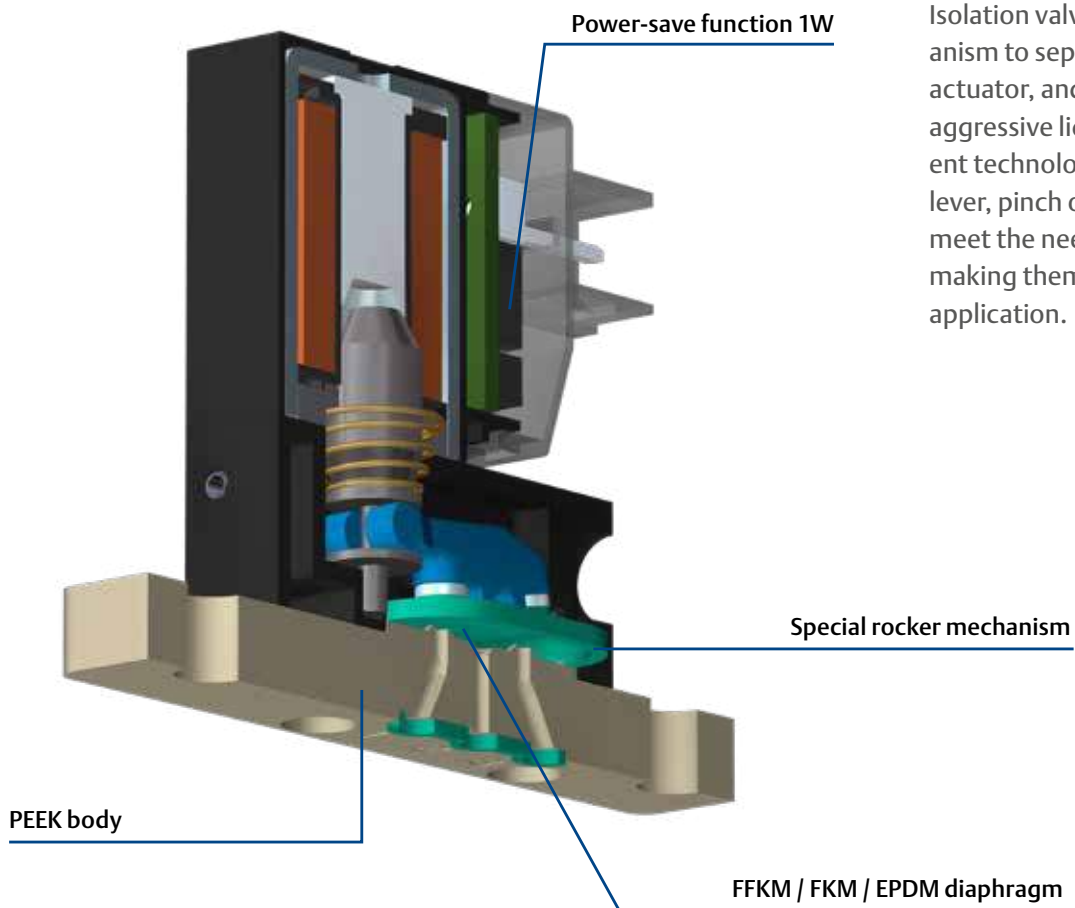

Isolation valves use a sealing mechanism to separate the fluid from the actuator, and are designed to handle aggressive liquids and gases. Different technologies such as a flapper, lever, pinch or rocker are designed to meet the needs of virtually any media, making them suitable for all kinds of application.

Diaphragm mechanism



- Diaphragm valves are known for their compact size, long service life and very low internal volume.
- The valve bodies are made of stainless steel or synthetic material (PTFE/PVDF).

Diaphragm valves ► p. 25

Rocker mechanism



- Rocker mechanism valves are designed to reduce the pumping effect seen in some low-viscous fluid applications.
- Multiple standard body configurations and connection types allow these valves to be exceptionally versatile across numerous applications.

Rocker valves ► pp. 31, 43, 73

... for a wide variety of analytical and medical applications

Flapper mechanism



- High pressures (up to 10 bar) are possible by the use of the special flapper mechanism and large orifice sizes.
- Holding power is lowered down to 1.5 watts, thus minimising the heat transfer into the fluid.

Flapper valves ► p. 35

Lever mechanism



- Lever valves can be used at high differential pressures and large flow volumes.
- Lever valves are suitable for use at high ambient temperatures since the offset control mechanism provides optimal heat dissipation in the electromagnetic component.

Lever valves ► p. 57

Pinch mechanism



- Characterized by their long service life, pinch valves offer exceptional versatility and reliability.
- Any risk of contamination is reliably avoided by changing the fluidic path tubing.

Pinch valves ► pp. 21, 49, 63

General Service Valves

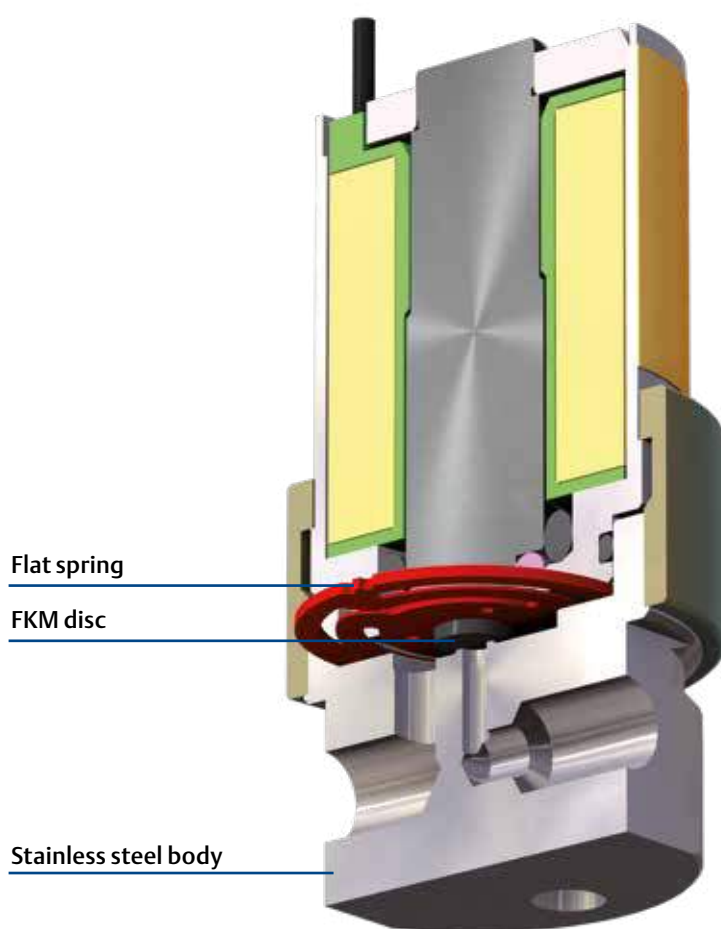

General service valves are used in handling inert gases in nearly any analytical or medical application, and are known for their long service life and reliability.

Their compact size and easy installation allow several valves to be mounted on a subbase or custom valve manifold.

Miniature Solenoid Valves

- Micro solenoid valves are used mainly as pilot valves or for the handling of inert gases.
- These series are suitable for applications in almost all areas of analytical and medical technology.
- Their compact size and easy installation allow several valves to be mounted on a subbase or custom valve module.

... for a wide variety of analytical and medical applications

9 - 11 mm



Series 188 ▶ p. 99

11 - 15 mm



Series RB ▶ p. 125

15 - 22 mm



Series S ▶ p. 131

Series 096 ▶ p. 89

Series 065 ▶ p. 77

Series 411 ▶ p. 117

Series 226 ▶ p. 107

> 22 mm



Series L256 ▶ p. 121



Series L123 / L257 / L323 ▶ p. 91

Proportional Valves

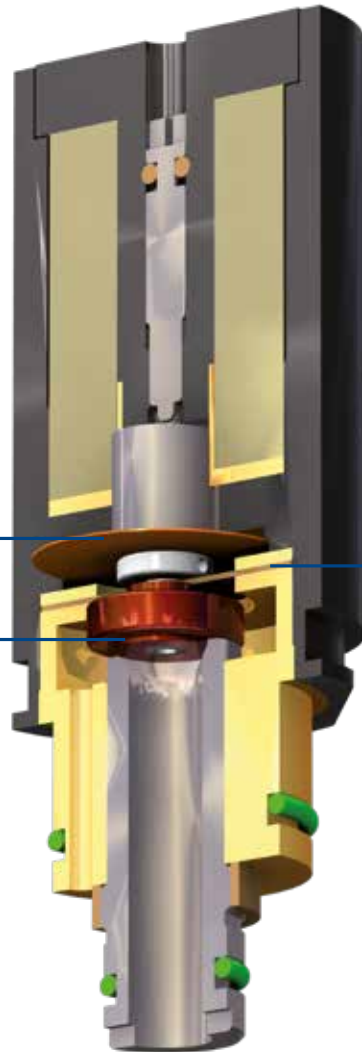

Flat spring

FKM disc

FKM diaphragm

Proportional valves quickly and accurately adjust output pressure in relation to an electrical control signal. They are designed for applications with quickly changing flow demands and are highly customizable.

Proportional technologies ...

Preciflow



- Series 202 2/2 proportional valves can be used in any Analytical & Medical application.
- Frictionless suspension of the core reduces hysteresis and provides stepless control in the lower and upper ranges.

Series 202, Preciflow ► p. 137

Preciflow IPC



- Series 202 Preciflow IPC valves are Inlet Pressure Compensated flow control valves. Inlet Pressure Compensation allows high pressures and flows at low solenoid coil power consumption.
- Typical applications for these valves are in medical (e.g. respirators) and analytical apparatus (e.g. mass flow controllers).

Series 202, Preciflow IPC ► p. 143

... for a wide variety of analytical and medical applications

Piezotronic



- Series 630 2/2 piezo valves for flow control are a high-tech solution designed in particular for applications requiring extremely low power consumption.
- They are suitable for use in battery-operated equipment or in potentially explosive areas.

Series 630, Piezotronic ► p. 151

Flapper Proportional



- This series 068 valve equipped with the flapper technology, one of the safest and most reliable solutions for media separation. It is combined with the advantages of the Proportional technology to ensure optimum flexibility to control of liquid media.

Series 068, Flapper Proportional ► p. 135



青岛秉诚自动化设备有限公司
地址：中国·青岛市重庆南路99号海尔云街甲3号楼7F

服务热线：4006-918-365
网址：<http://www.ivalve.cc>

传真：(86-532)585-10-365
Email：sales@bechinas.com

Data Sheets – Table of Contents

Fluid Isolation Valves

Series 045	21
Series 055	25
Series 058	29
Series 067	31
Series 068	35
Series 110	43
Series S170 / S370	49
Series 283 / 383	57
Series 284	63
Series 384	69
Series 385	73

General Service Valves

Series 065	77
Series 076	81
Series 090	85
Series 096	89
Series L123 / L257 / L323	91
Series 188	99
Series 226	107
Series 411	117
Series L256	121
Series RB	125
Series S	131

Proportional Valves

Series 068 Flapper Proportional	135
Series 202 Preciflow 12.7mm	137
Series 202 Preciflow 15mm	139
Series 202 Preciflow IPC und Preciflow 19mm	143
Series 614 Sentronic ^{Plus} IPC	147
Series 630 Piezotronic	151

Manifolds & Accessories

Series 252	153
Series 624	157
Series 881 Connectors	159
Series 908 Electronic Control Unit	165
Pinch Valve Tubing & Guide	167

Engineering Information

Solenoid Valves – Information & Terminology	169
Chemical Resistance Guide	173
Conversion Tables	177

ASCO™ MINIATURE SOLENOID VALVES

PINCH VALVES, COMPACT 2-WAY / 3-WAY SOLENOID

- The 045 Series are compact 2-way and 3-way solenoid pinch valves designed for use with highly aggressive or high-purity liquids in analytical and medical instrumentation, and industrial applications
- Hermetic separation of control mechanism and the fluid within the tubing prevents particulate contamination caused by friction of moving parts, assuring maximum purity of liquids
- Available in a range of body sizes to accommodate a wide variety of tubing sizes
- Meets all relevant CE directives, and is RoHS compliant
- Typical applications include:
 - Hemodialysis
 - Bioinstrumentation
 - Surgical Fluid Management
 - Pharmaceutical

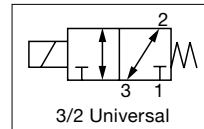
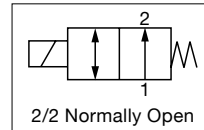
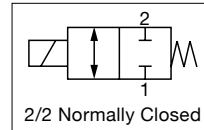

2-way

Fluids*	Temperature Range
Air, Inert Gases, Water, Oil or Liquids	0°C to 70°C (32°F to 158°F)

* Ensure that the compatibility of the materials in contact with the fluids is verified.

Materials in Contact with Fluid	
Recommended Tubing	VMQ (silicone) (max. hardness: 50 Shore A)
Other Materials	
Body	Aluminum
Pinch Mechanism	POM, Aluminum
Internal Parts	Stainless Steel
Response Time	5 to 25ms

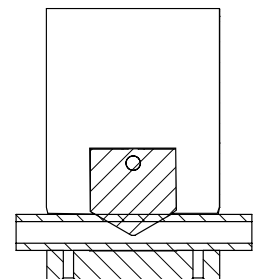

2-way

Electrical Characteristics	
Coil Insulation Class	F
Connector	22 AWG or 24 AWG Lead wires, 457mm (18in) long, PTFE coated
Electrical Safety	IEC 335
Electrical Enclosure Protection	IP64
Standard Voltages	12 VDC, 24 VDC
Power Consumption	1.0 to 7.2 Watts

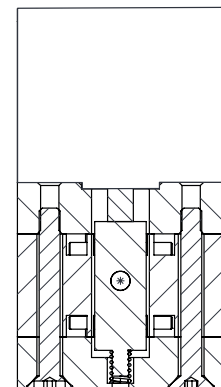

3-way

Specifications					
Tube O.D.	Tube I.D.	Operating Pressure bar (psi)		Power Rating W	Tubing Size
		min.	max.		
1.65 (0.065)	0.762 (0.030)	0	2.07 (30)	1	01
2.38 (3/32)	0.794 (1/32)	0	2.07 (30)	1.5	02
3.17 (1/8)	1.59 (1/16)	0	2.07 (30)	1.5	03
4.76 (3/16)	1.59 (1/16)	0	2.07 (30)	4.2	04
6.35 (1/4)	3.17 (1/8)	0	1.38 (20)	4.2	05
7.94 (5/16)	4.76 (3/16)	0	1.38 (20)	7.2	06
9.52 (3/8)	6.35 (1/4)	0	1.38 (20)	7.2	07

01065GB-2020-R01

How to Order

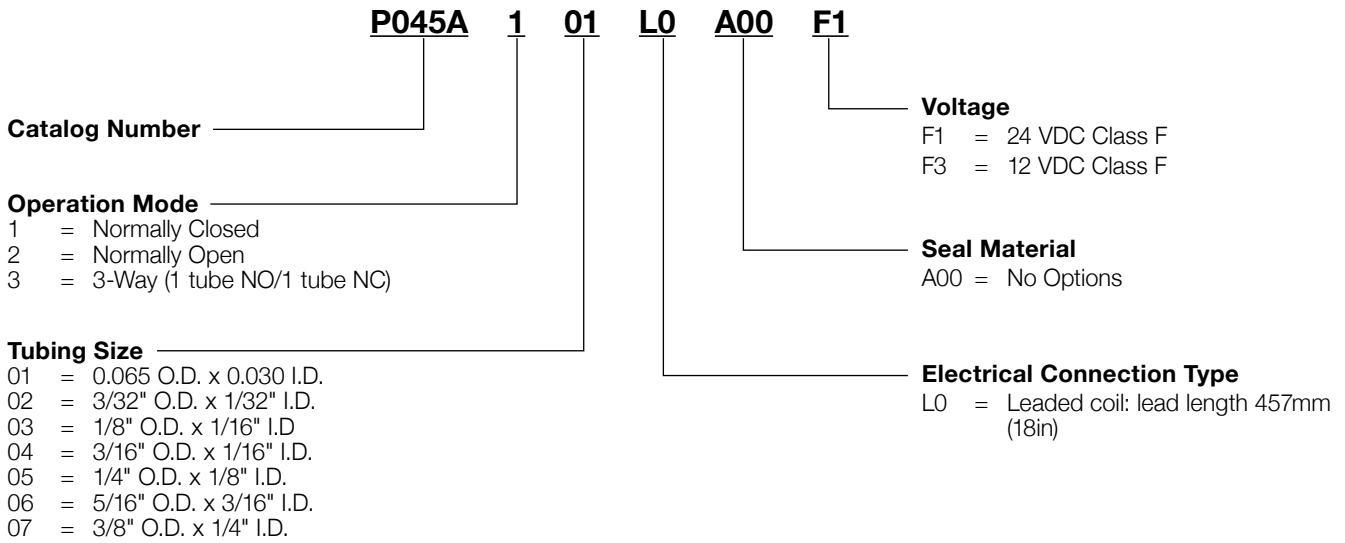

Options

- Contact us for information regarding the usage of different tubing other than those recommended

Installation

- The solenoid valves can be mounted in any position without affecting operation, however, for optimum performance it is recommended that they be fitted with the solenoid operator at the top.
- In case the tubing is not placed in its seat, the solenoid valve could operate incorrectly.
- 305mm (12in) Flexible tubing is pre-installed with each valve.

ASCO™ MINIATURE SOLENOID VALVES

PINCH VALVES, COMPACT 2-WAY / 3-WAY SOLENOID

Dimensions: mm (inches)

2-Way Solenoid

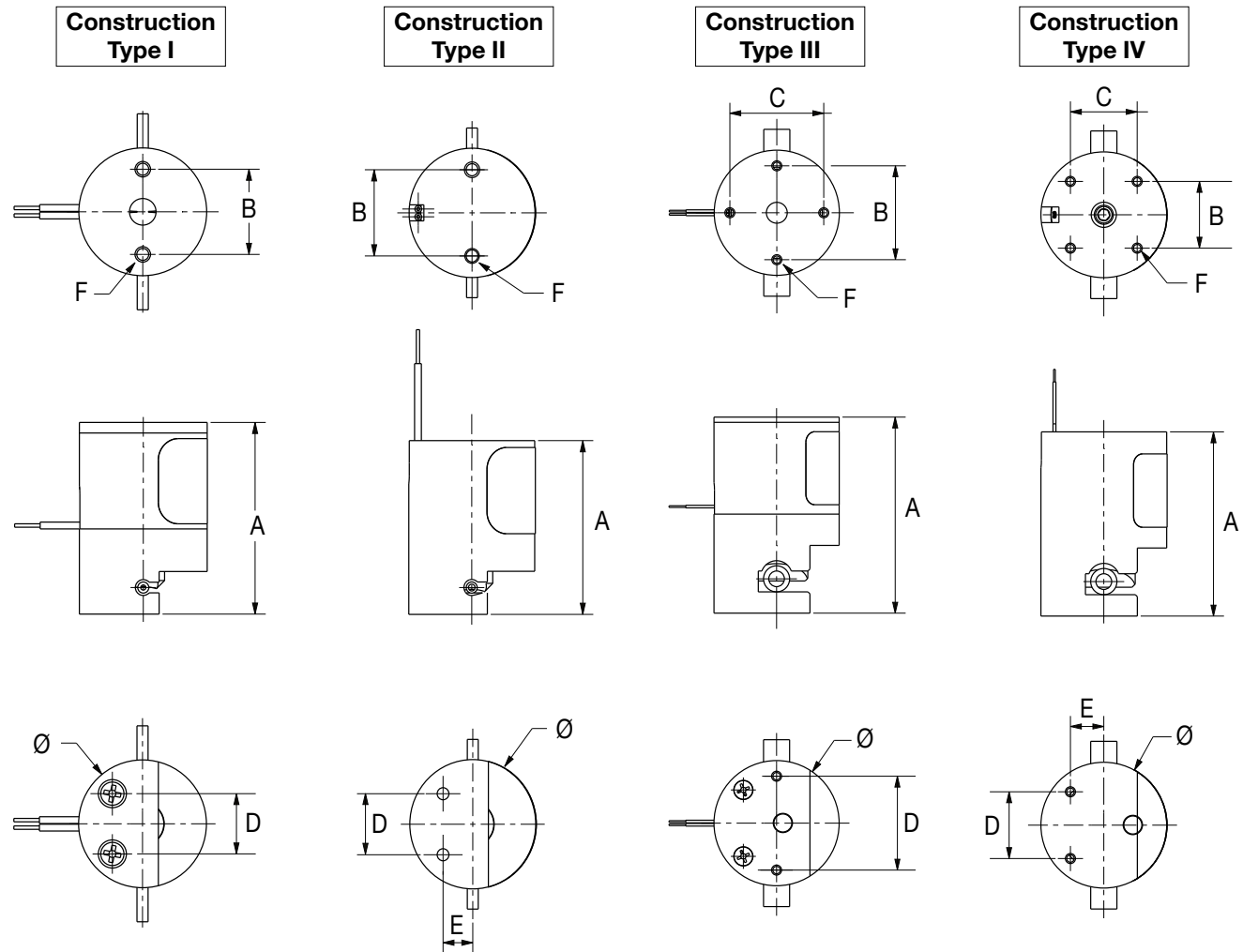

Config-uration	Construction Type	Tubing Size	Ø	A	B	C	D	E	F
NO	I	01	19.05 (0.750)	28.58 (1.125)	12.70 (0.500)	-	-	-	#2-56
NC	II	01		25.45 (1.002)	12.70 (0.500)	-	8.99 (0.354)	4.50 (0.177)	
NO	III	02 / 03	25.40 (1.000)	37.25 (1.467)	17.45 (0.687)	17.45 (0.687)	17.45 (0.687)	-	#4-40
NC	IV	02 / 03		37.12 (1.462)	12.34 (0.486)	12.34 (0.486)	12.34 (0.486)	6.17 (0.243)	
NO	III	04 / 05	31.75 (1.250)	50.79 (2.000)	22.45 (0.884)	22.45 (0.884)	22.45 (0.884)	-	#4-40
NC	IV	04 / 05		46.91 (1.847)	15.90 (0.626)	15.90 (0.626)	15.90 (0.626)	7.95 (0.313)	
NO	III	06 / 07	38.10 (1.500)	59.68 (2.350)	28.58 (1.125)	28.58 (1.125)	28.58 (1.125)	-	#4-40
NC	IV	06 / 07		55.80 (2.197)	20.22 (0.796)	20.22 (0.796)	20.22 (0.796)	10.11 (0.398)	

01065GB-2020-R01

Dimensions: mm (inches)

3-Way Solenoid

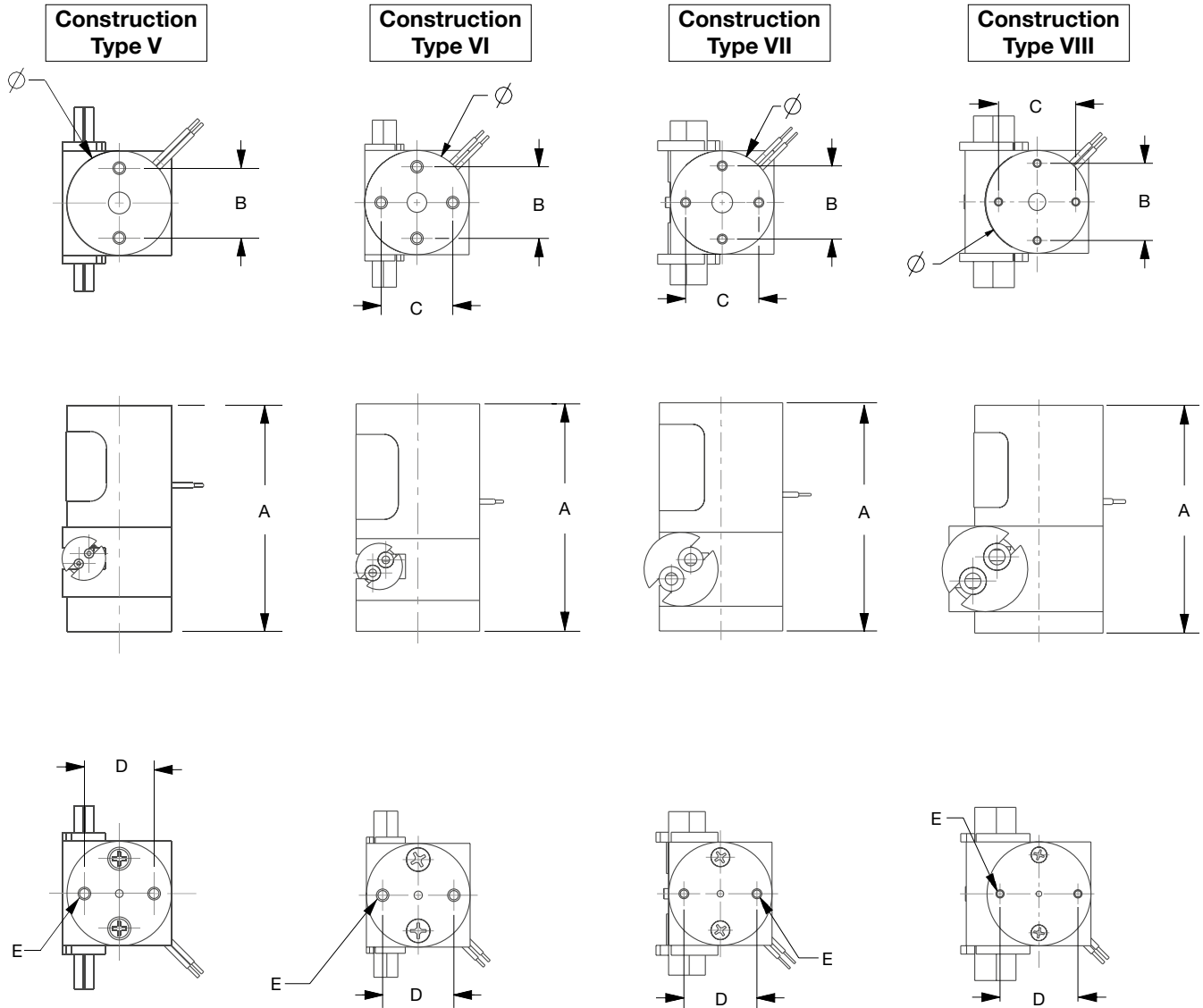

Construction Type	Tubing Size	Ø	A	B	C	D	E
V	01	19.05 (0.750)	41.28 (1.625)	12.70 (0.500)	-	12.70 (0.500)	#2-56
VI	02	25.40 (1.000)	46.77 (1.842)	17.45 (0.687)	17.40 (0.687)	17.45 (0.687)	#4-40
	03						
VII	04	31.75 (1.250)	58.74 (2.313)	22.45 (0.884)	22.45 (0.884)	22.45 (0.884)	#4-40
	05						
VIII	06	38.1 (1.500)	67.63 (2.663)	28.58 (1.125)	28.58 (1.125)	28.58 (1.125)	#4-40

ASCO™ MINIATURE SOLENOID VALVES

PTFE DIAPHRAGM FLUID ISOLATION VALVES

- PTFE isolation valves are designed for use with highly aggressive liquids
- The PTFE body and diaphragm isolates the internal solenoid components from the media
- Excellent self-draining capability and easy-to-flush low-volume internal cavity
- Compact architecture make them ideal for analytical bench-top instrumentation
- Available in 2-Way normally closed, 2-Way normally open, and 3-Way universal; comes with #10-32, 1/4-28, or 1/8 NPSC in-line porting for exceptional versatility
- Meets all relevant CE directives
- Typical applications include:
 - Chromatography
 - Solvent Selection/Diversion
 - Sample Preparation
 - DNA Sequencing

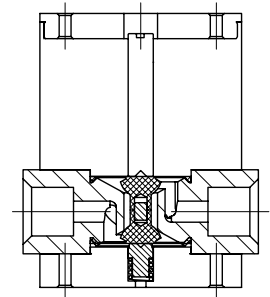
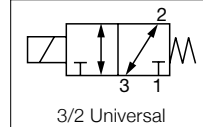
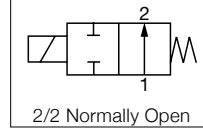
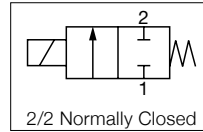

Fluids*	Temperature Range	Seal Materials*
Aggressive liquids	0°C to 70°C (32°F to 158°F)	PTFE

*Ensure that the compatibility of the materials in contact with the fluids is verified

General Valve Information*	
Body	PTFE / Stainless steel
Poppet	PTFE
Diaphragm	PTFE
Response Time	< 20ms
Internal Volume	As low as 18 µl

* Ensure that the compatibility of the materials in contact with the fluids is verified

Electrical Characteristics	
Coil Insulation Class	F
Connector	22 AWG or 24 AWG Lead wires, 457mm (18in) long, PTFE coated
Standard Voltages	12 VDC, 24 VDC
Power Consumption	1.0 to 7.2 Watts

Specifications						
Connection	Orifice Size mm (inches)	Flow Coefficient		Operating Pressure bar (psi)		Power Rating (W)
		Kv (m³/h)	Cv	min.	max. gas / liquids	
#10-32	1.02 (0.040)	0.010	0.012	-0.9 (-13)	2.07 (30)	1
1/4-28	1.57 (0.062)	0.023	0.027	-0.9 (-13)	2.07 (30)	1.5
1/4-28	2.36 (0.093)	0.050	0.058	-0.9 (-13)	2.07 (30)	4.2
1/8 NPSC	3.96 (0.156)	0.186	0.215	-0.9 (-13)	2.07 (30)	7.2

01066GB-2019-R01

How to Order

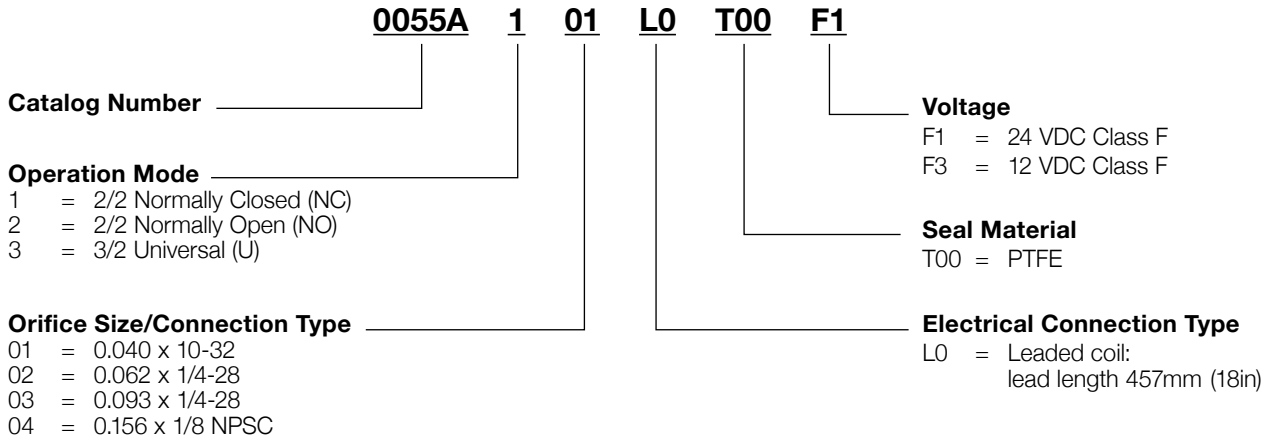

ASCO™ MINIATURE SOLENOID VALVES

PTFE DIAPHRAGM FLUID ISOLATION VALVES

SERIES
055

Dimensions: mm (inches)

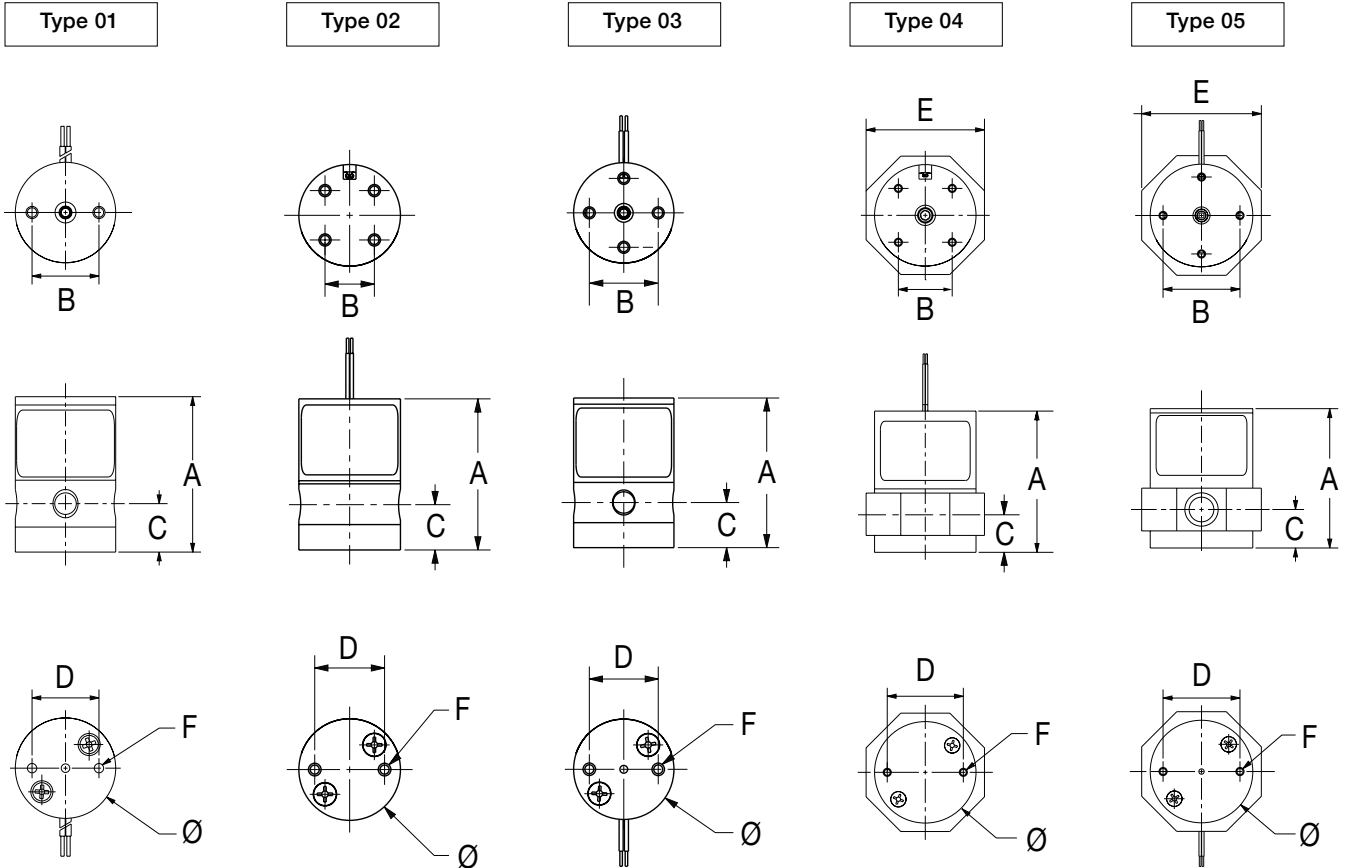

Configuration	Type	Catalog Number	Ø	A	B	C	D	E	F
2-Way NC	01	0055A101L0T00xx	19.05 (0.750)	29.34 (1.155)	12.70 (0.500)	9.220 (0.363)	12.70 (0.500)	-	#2-56
	02	0055A102L0T00xx	25.40 (1.000)	37.78 (1.488)	12.34 (0.486)	11.43 (0.450)	17.45 (0.687)	-	#4-40
	04	0055A103L0T00xx	31.75 (1.250)	47.32 (1.863)	15.90 (0.626)	12.70 (0.500)	22.45 (0.884)	38.10 (1.500)	
	04	0055A104L0T00xx	38.10 (1.500)	53.04 (2.088)	20.22 (0.796)	14.27 (0.562)	28.58 (1.125)	44.45 (1.750)	
2-Way NO	01	0055A201L0T00xx	19.05 (0.750)	29.54 (1.163)	12.70 (0.500)	9.220 (0.363)	12.70 (0.500)	-	#2-56
	03	0055A202L0T00xx	25.40 (1.000)	37.91 (1.493)	17.45 (0.687)	11.43 (0.450)	17.45 (0.687)	-	#4-40
	05	0055A203L0T00xx	31.75 (1.250)	46.06 (1.814)	22.45 (0.884)	12.70 (0.500)	22.45 (0.884)	38.10 (1.500)	
	05	0055A204L0T00xx	38.10 (1.500)	51.78 (2.039)	28.58 (1.125)	14.27 (0.562)	28.58 (1.125)	44.45 (1.750)	
3-Way	01	0055A301L0T00xx	19.05 (0.750)	29.49 (1.161)	12.70 (0.500)	9.220 (0.363)	12.70 (0.500)	-	#2-56
	03	0055A302L0T00xx	25.40 (1.000)	37.88 (1.492)	17.45 (0.687)	11.42 (0.450)	17.45 (0.687)	-	#4-40
	05	0055A303L0T00xx	31.75 (1.250)	46.06 (1.814)	22.45 (0.884)	12.70 (0.500)	22.45 (0.884)	38.10 (1.500)	
	05	0055A304L0T00xx	38.10 (1.500)	51.75 (2.038)	28.58 (1.125)	14.27 (0.562)	28.58 (1.125)	44.45 (1.750)	

01066GB-2019-R01

ASCO™ MINIATURE SOLENOID VALVES

DIAPHRAGM COMPACT 2-WAY SOLENOID ISOLATION VALVE

- Direct acting solenoid valve for use with neutral or aggressive liquids in analytical instruments
- Media separating soft-seal PTFE diaphragm, prevents any potential leakage of critical reagents within the instrument compartment
- Low power consumption results in less heat transfer to thermally sensitive reagents and samples
- Small form-factor saves space in OEM instruments and is well-suited for portable and hand-held field devices
- Typical application include:
 - Clinical Diagnostics
 - DNA Sequencing
 - Liquid Chromatography
 - Sample Preparation

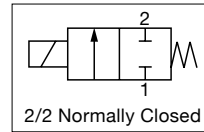

Fluids*	Temperature Range	Seal Materials*
Liquids or Gases	0°C to 40°C (32°F to 104°F)	FKM, FFKM

* Ensure that the compatibility of the materials in contact with the fluids is verified.

General Valve Information	
Body	PPS, PEEK
Diaphragm	PTFE
Response Time	< 10ms
Internal Volume	29µl
Max Viscosity	20 cSt (mm ² /s)

Electrical Characteristics	
Coil Insulation Class	F
Connector	Lead Wires
Connector Specification	28 AWG PTFE coated
Electrical Safety	IEC 335
Electrical Enclosure Protection	IP65 (EN 60529)
Standard Voltages*	12 VDC, 24 VDC (±5%)

Electrical Connection	Power Ratings				Ambient Temperature Range
	Inrush	Holding		Hot/Cold	
	VA	VA	W	W	C° (F°)
L0	-	-	-	2.8	0 to 40 (32 to 104)

Specifications							
Connection	Orifice Size	Flow Coefficient		Operating Pressure bar (psi)			
				min.	max.	Power Rating (W)	Catalog Number
mm (inches)	Kv (m ³ /h)	Cv	gas / liquids				
2/2 NC - Normally Closed							
Pad Mounting	1.00 (0.04)	0.018	0.021	-0.2 bar (-2.9 psi)	2.0 bar (29 psi)	2.8	R058A001L0XXXXX
Pad Mounting	1.00 (0.04)	0.018	0.021	-0.2 bar (-2.9 psi)	2.0 bar (29 psi)	2.8	R058A002L0XXXXX

01083GB-2019-R01

How to Order

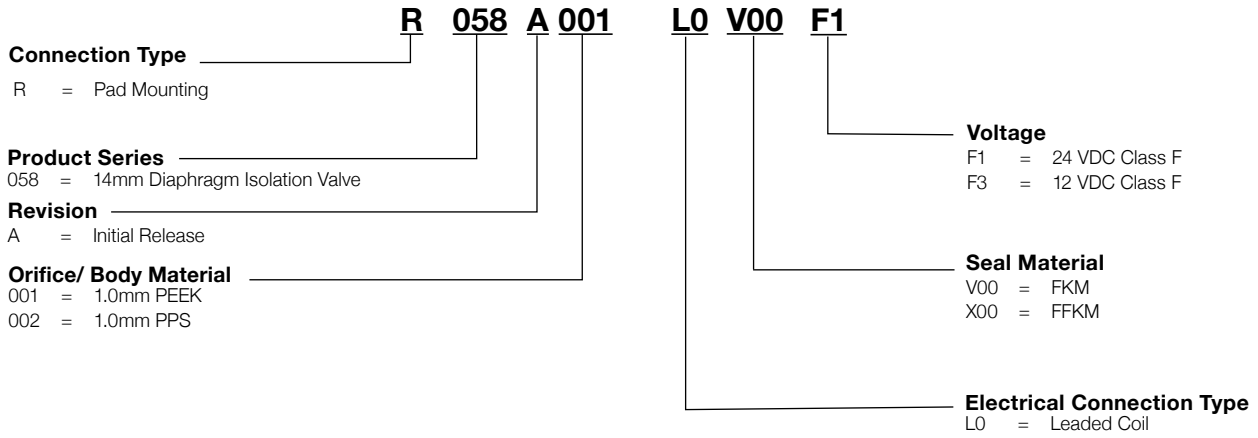

Dimensions: mm (inches)

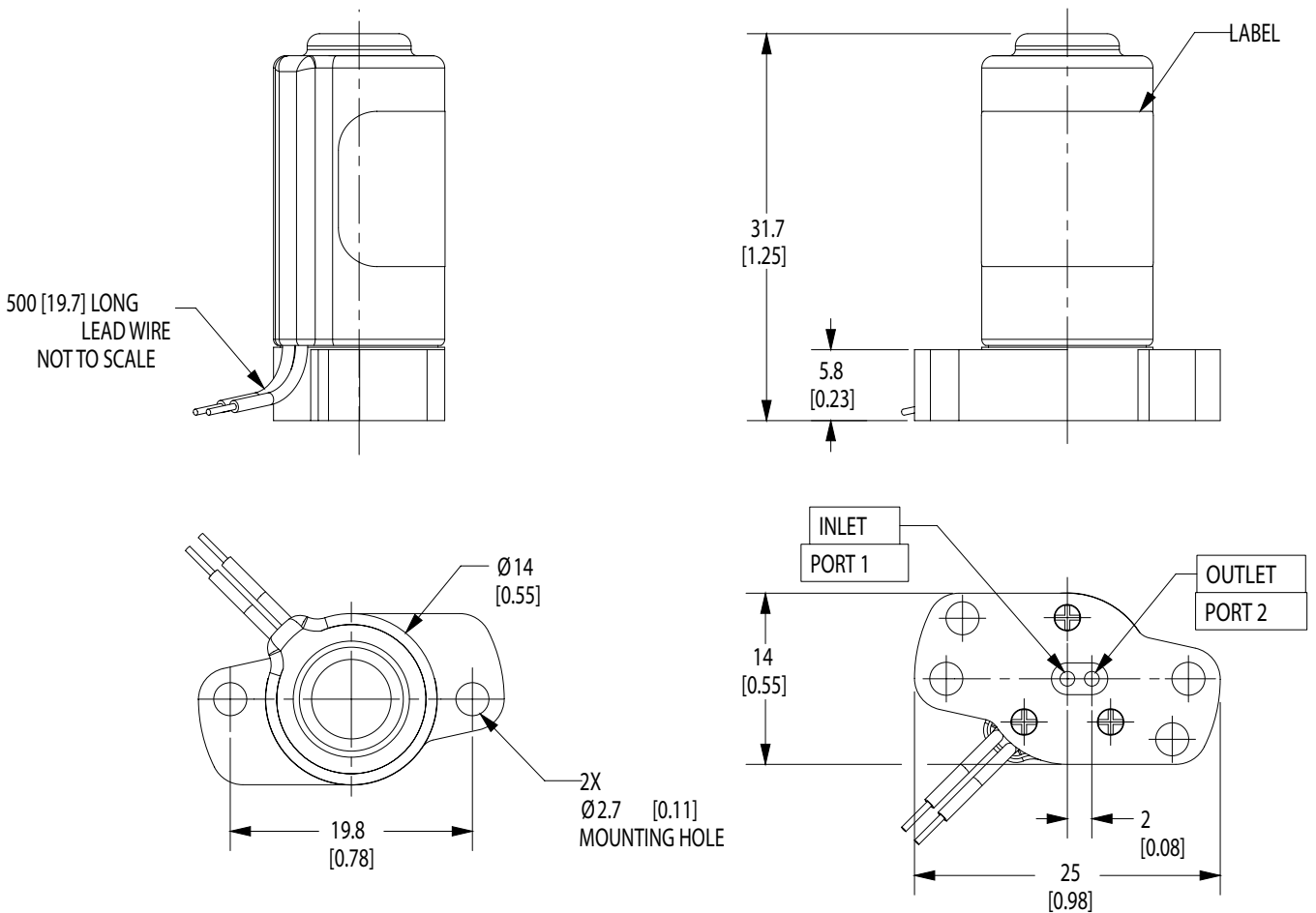

01083GB-2019-R01

ASCO™ MINIATURE SOLENOID VALVES

ROCKER SOLENOID FLUID ISOLATION VALVES

- Rocker isolation valves are designed for use with neutral or highly aggressive liquids in analytical instrumentation
- Special rocker mechanism, combined with a separating diaphragm, prevents heat transfer to the fluid and eliminates the sticking effect of the valve seat
- Hermetic separation of control mechanism prevents particulate contamination caused by friction of moving parts, assuring maximum purity of liquid samples
- Excellent self-draining capability and easy-to-flush low-volume internal cavity make these valves ideal in applications where cross-contamination must be minimized
- “Hit and Hold” feature utilizes an integrated power-save switch that reduces analytical instrument power consumption
- Meets all relevant CE directives, and is RoHS compliant
- Typical applications include:
 - Pipette Dispensing
 - In-vitro Diagnostics
 - DNA Sequencing
 - Surgical Fluid Management

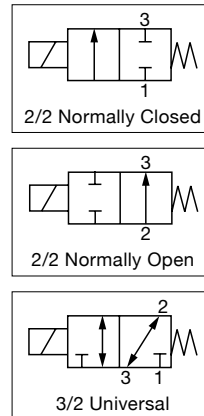

Functional Principle

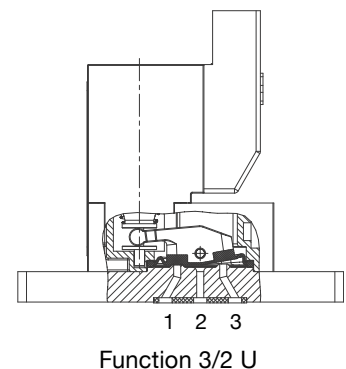
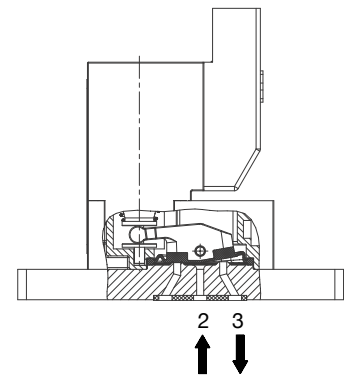
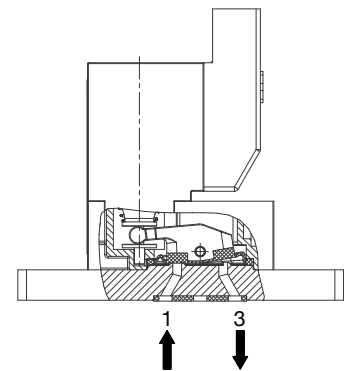

Fluids*	Temperature Range	Seal Materials*
Liquids or Gases	10 °C to 40 °C (50 °F to 104 °F)	FKM/FFKM
	5 °C to 40 °C (41 °F to 104 °F)	EPDM

*Ensure that the compatibility of the materials in contact with the fluids is verified.

General Valve Information	
Body	PEEK
Others	Stainless Steel
Response Time	< 10ms
Internal Volume	10µl
Max. Viscosity	20 cSt (mm ² /s)

Electrical Characteristics	
Coil Insulation Class	F
Connector	Pin Header with 2 Contacts
Electrical Safety	EN 60335
Electrical Enclosure Protection	IP65 (EN 60529)
Standard Voltages*	12 VDC, 24 VDC (-5%/+10%)

* Other voltages on request

Coil Type ¹	Power Rating	Ambient Temperature Range	Protection	Electrical Connection
	Inrush/Holding			
	W	°C (°F)	VA	
Specific	2.5/1.0*	10 to 50 (50 to 122)	IP40	Connector with two 0.5mm ² lead wires + built-in LED and electrical protection or lead wires, 0.5m (19.7in) long

* With power-save electronics

¹ The coil used for orifice size 1.35mm (0.053in) is longer by 12.5mm (0.49in) than that used for the other orifice sizes, see drawings on following pages

00191GB-2019-R01

Specifications										
Connection	Orifice Size mm (inches)	Flow Coefficient		Operating Pressure bar (psi)			Electrical Connection/ Type*	Catalog Number	Seal Material ²	
		Kv (m ³ /h)	Cv	min.	max. gases liquids				FKM	EPDM
2/2 NC - Normally Closed										
Long Flange ¹	0.6 (0.024)	0.006	0.007	-0.9 (-13)	3 (43.5)	3 (43.5)	1	SC S067A 021	V	E
							2	SC S067A 022		
							3	SC S067A 023		
							4	SC S067A 024		
							5	L S067A 025		
	0.8 (0.031)	0.010	0.012	-0.9 (-13)	2 (29.0)	2 (29.0)	1	SC S067A 026	V	E
							2	SC S067A 027		
							3	SC S067A 028		
							4	SC S067A 029		
							5	L S067A 030		
	1.0 (0.040)	0.017	0.020	-0.9 (-13)	1.5 (21.8)	1.5 (21.8)	1	SC S067A 031	V	E
							2	SC S067A 032		
							3	SC S067A 033		
							4	SC S067A 034		
							5	L S067A 035		
	1.35 (0.053)	0.026	0.030	-0.9 (-13)	1.0 (14.5)	1.0 (14.5)	1	SC S067A 036	V	E
2							SC S067A 037			
3							SC S067A 038			
4							SC S067A 039			
5							L S067A 040			
2/2 NO - Normally Open										
Long Flange ¹	0.6 (0.024)	0.006	0.007	-0.9 (-13)	3 (43.5)	3 (43.5)	1	SC S067A 061	V	E
							2	SC S067A 062		
							3	SC S067A 063		
							4	SC S067A 064		
							5	L S067A 065		
	0.8 (0.031)	0.010	0.012	-0.9 (-13)	2 (29.0)	2 (29.0)	1	SC S067A 066	V	E
							2	SC S067A 067		
							3	SC S067A 068		
							4	SC S067A 069		
							5	L S067A 070		
	1.0 (0.040)	0.017	0.020	-0.9 (-13)	1.5 (21.8)	1.5 (21.8)	1	SC S067A 071	V	E
							2	SC S067A 072		
							3	SC S067A 073		
							4	SC S067A 074		
							5	L S067A 075		
	1.35 (0.053)	0.026	0.030	-0.9 (-13)	1.0 (14.5)	1.0 (14.5)	1	SC S067A 076	V	E
2							SC S067A 077			
3							SC S067A 078			
4							SC S067A 079			
5							L S067A 080			
3/2 U-Universal										
Long Flange ¹	0.6 (0.024)	0.006	0.007	-0.9 (-13)	3 (43.5)	3 (43.5)	1	SC S067A 101	V	E
							2	SC S067A 102		
							3	SC S067A 103		
							4	SC S067A 104		
							5	L S067A 105		
	0.8 (0.031)	0.010	0.012	-0.9 (-13)	2 (29.0)	2 (29.0)	1	SC S067A 106	V	E
							2	SC S067A 107		
							3	SC S067A 108		
							4	SC S067A 109		
							5	L S067A 110		
	1.0 (0.040)	0.017	0.020	-0.9 (-13)	1.5 (21.8)	1.5 (21.8)	1	SC S067A 111	V	E
							2	SC S067A 112		
							3	SC S067A 113		
							4	SC S067A 114		
							5	L S067A 115		
	1.35 (0.053)	0.026	0.030	-0.9 (-13)	1.0 (14.5)	1.0 (14.5)	1	SC S067A 116	V	E
2							SC S067A 117			
3							SC S067A 118			
4							SC S067A 119			
5							L S067A 120			

* Types 1 to 5 with power-save electronics, LED and electrical protection, mm (inches)

- 1 = width: 5.08 (0.2)
- 2 = width: 5.08 (0.2)
- 3 = width: 2.54 (0.1)
- 4 = width: 2.54 (0.1)
- 5 = Flying Leads, 0.5 (19.7) long (see drawings on following page)

¹ 2 hexagon socket head cap mounting screws M3x6mm (0.24in), stainless steel, ISO4762 supplied

² To order FFKM seals, leave the corresponding designation in the catalog number "blank".

ASCO™ MINIATURE SOLENOID VALVES

ROCKER SOLENOID FLUID ISOLATION VALVES

Dimensions: mm (inches)

Type 1

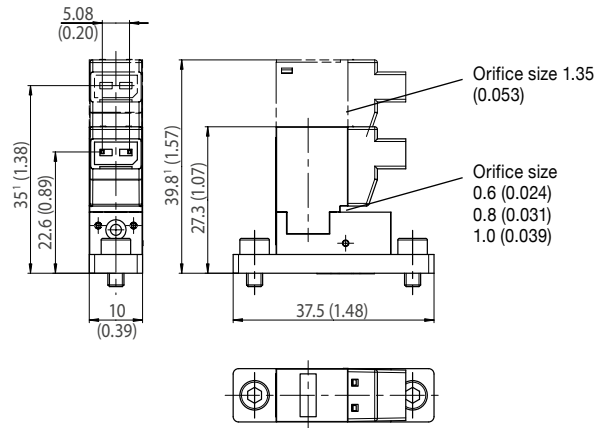

Type 2

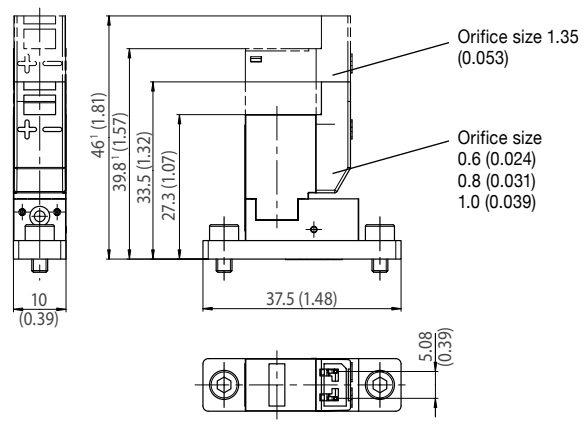

Type 3

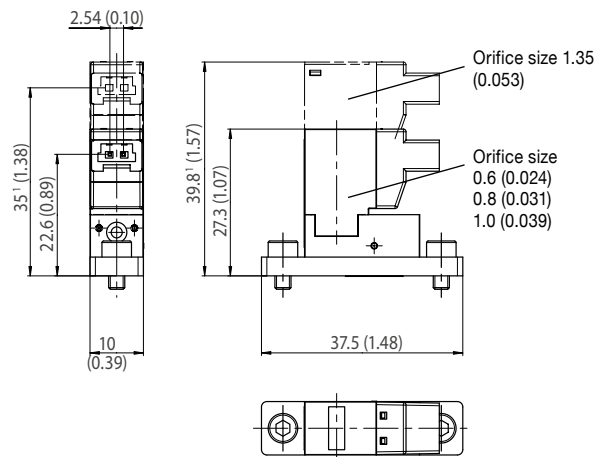

Type 4

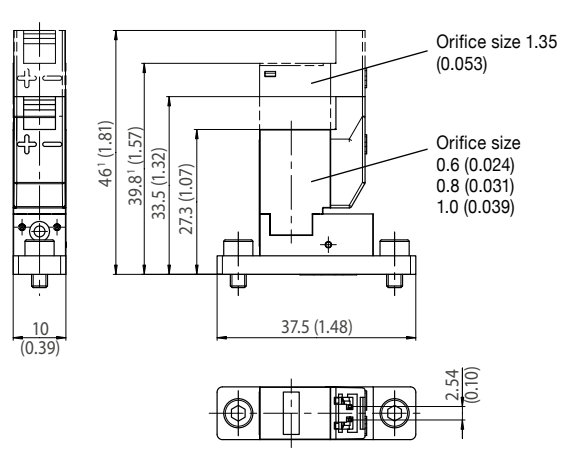

Type 5

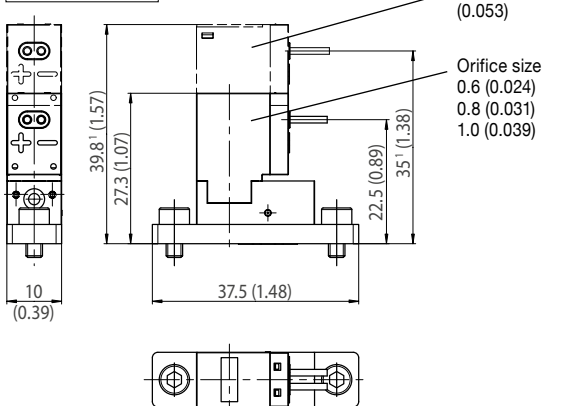

Mounting Pad

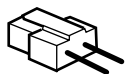
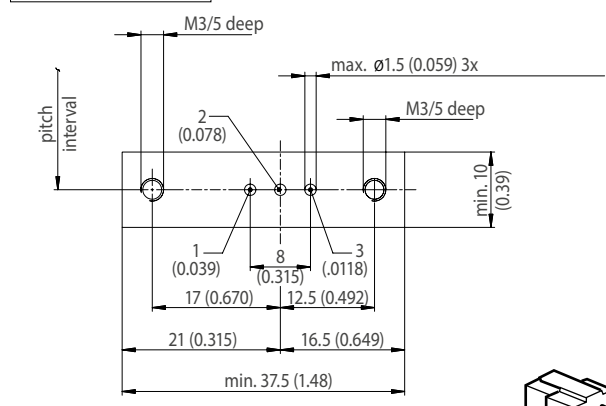

¹ The coil used for orifice size 1.35mm (0.053in) is longer by 12.5mm (0.492in) than that used for the other orifice sizes
 NOTE: Connectors must be ordered separately, please specify the quantity and Catalog numbers required:

Pin spacing 5.08 (0.20)	0.5m (19.7in) long	Catalog number: 88118801	0.5m (19.7in) long	Catalog number: 88118806
	1.5m (59in) long	Catalog number: 88118802	1.5m (59in) long	Catalog number: 88118807
	3m (118in) long	Catalog number: 88118803	3m (118in) long	Catalog number: 88118808

00191GB-2019-R01

Dimensions: mm (inches)

**Single Subbases
PEEK**

UNF thread -
Catalog number **36100038**

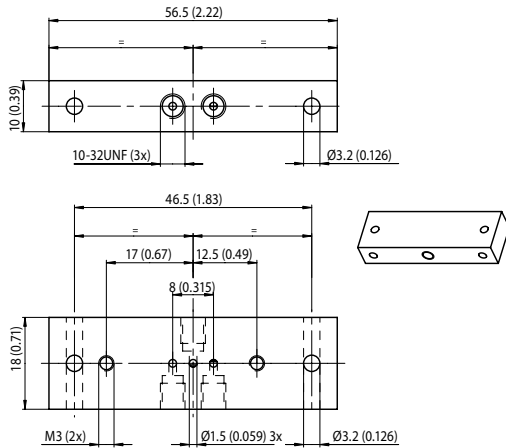

Bottom push-in hose connection -
Catalog number **36100042**

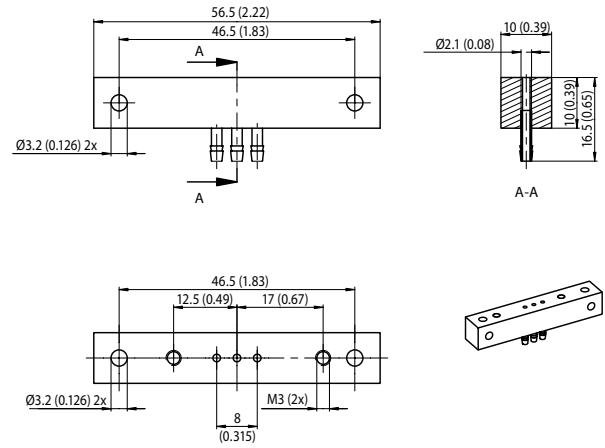

UNF thread -
Catalog number **36100040**

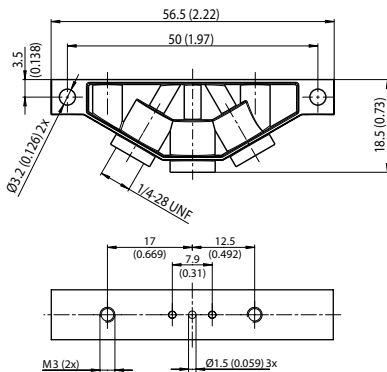

Side push-in hose connection -
Catalog number **36100044**

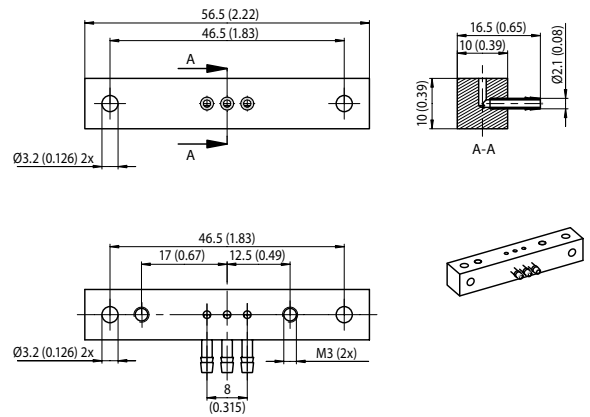

Options

- Subbases available on request
- Manual operator (impulse-type)

Installation

- The solenoid valves can be mounted in any position without affecting operation

ASCO™ MINIATURE SOLENOID VALVES

FLAPPER FLUID ISOLATION VALVES, 16mm

- Flapper isolation valves are designed for use with neutral or highly aggressive liquids in analytical and medical systems
- Special Flapper mechanism results in no pumping or sticking effects
- Reduced heat transfer between control mechanism and fluid make them ideal for use with heat-sensitive reagents and biological samples
- Hermetic separation of control mechanism prevents particulate contamination caused by friction of moving parts, assuring maximum purity of liquid samples
- Excellent self-draining capability and easy-to-flush low-volume internal cavity make these valves ideal in application where cross-contamination must be minimized
- Meets all relevant CE directives, and is RoHS compliant
- Typical applications include:
 - In-vitro Diagnostics
 - Hematology
 - DNA Sequencing
 - Industrial Liquid Analyzers

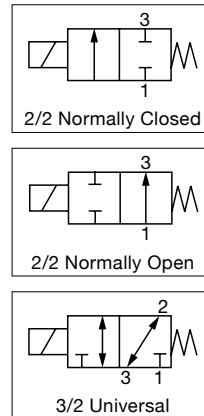

Fluids*	Temperature Range	Seal Materials*
Liquids or Gases ¹	5 °C to 50 °C (41 °F to 122 °F)	FFKM
		FKM
		EPDM

¹ Filtration: 50µm

* Ensure that the compatibility of the materials in contact with the fluids is verified

General Valve Information	
Body	PEEK
Others	Stainless Steel
Response Time	< 20ms
Internal Volume	75µl
Max. Viscosity	20 cSt (mm ² /s)

Electrical Characteristics	
Coil Insulation Class	F
Connector	Spade terminals or lead wires ²
Connector Specification	Spade terminals: DIN 46340, lead wires: 24 AWG
Electrical Safety	IEC 335
Electrical Enclosure Protection	Molded IP65 spade terminals (EN 60529) Molded IP66 lead wires (EN 60529)
Standard Voltages*	12 VDC, 24 VDC (-5%/+10%)

Electrical Connection	Power Ratings			Ambient Temperature Range	Type1
	Inrush VA	Holding VA	Hot/Cold W		
S0	-	-	-	5 to 50 (41 to 122)	01
L0	-	-	4		02

* Other voltages or coil with red LED for power supply signal on request

¹ Refer to the drawings on following pages

² 0.5m (19.7in) lead wires

Functional Principle

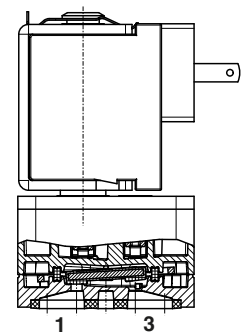

Function 2/2 NC

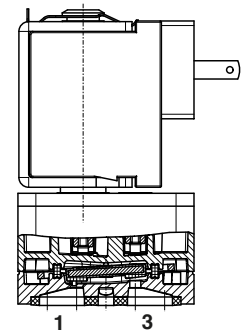

Function 2/2 NO

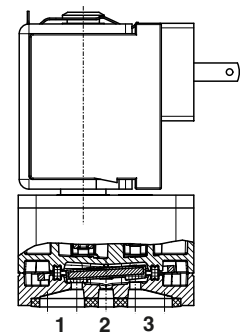

Function 3/2 U

01044GB-2019-R01

Specifications						
Connection	Orifice Size	Flow Coefficient		Operating Pressure bar (psi)		Power Rating (W)
				min.	max. gases or liquids	
	mm (inches)	Kv (m³/h)	Cv			
Pad Mounting ¹	0.8 (0.031)	0.021	0.024	-0.9 (-13)	8 (116)	4
	1.2 (0.047)	0.036	0.042	-0.9 (-13)	4 (58)	4
	1.6 (0.063)	0.042	0.049	-0.9 (-13)	2 (29)	4
1/4-28 UNF	0.8 (0.031)	0.021	0.024	-0.9 (-13)	8 (116)	4
	1.2 (0.047)	0.036	0.042	-0.9 (-13)	4 (58)	4
	1.6 (0.063)	0.042	0.049	-0.9 (-13)	2 (29)	4
Push-in Hose Connection	0.8 (0.031)	0.021	0.024	-0.9 (-13)	8 (116)	4
	1.2 (0.047)	0.036	0.042	-0.9 (-13)	4 (58)	4
	1.6 (0.063)	0.042	0.049	-0.9 (-13)	2 (29)	4

¹ 2 hexagon socket head cap mounting screws M2.5, stainless steel, supplied

How to Order

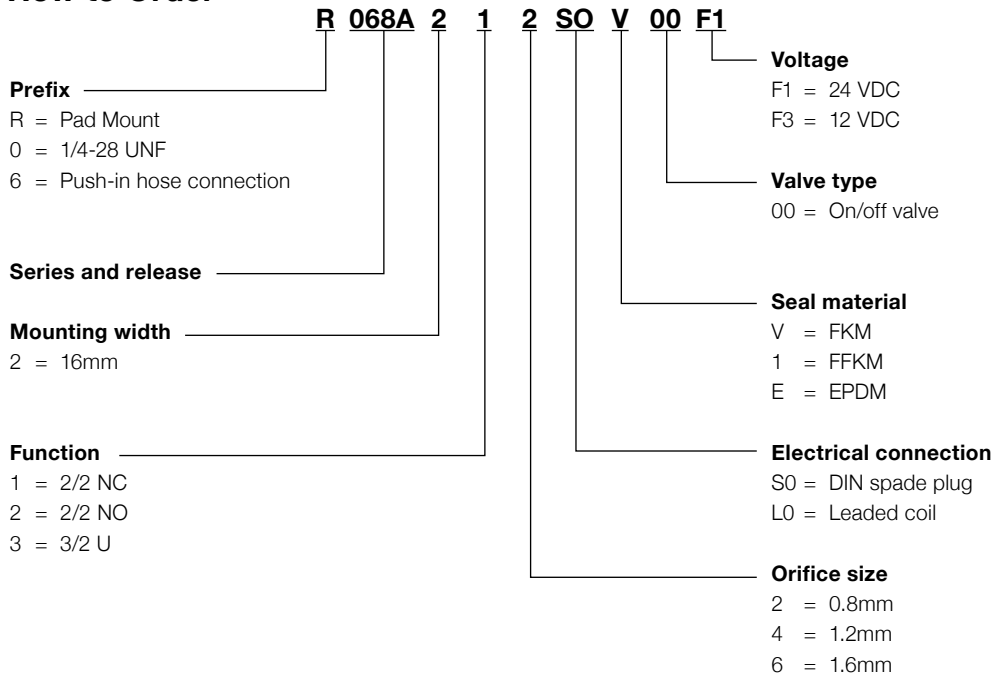

Options

Description	Catalog Number
Push-in-Hose Barb Kit 3/2	
Subbase Qty: 1	534662-001
Hex nut Qty: 2	
Push-in-Hose Barb Kit 2/2 Codification	
Subbase Qty: 1	534662-002
Hex nut Qty: 2	
1/4-28 Threaded Kit 3/2	
Subbase Qty: 1	534661-001
Hex nut Qty: 2	
1/4-28 Threaded Kit 2/2	
Subbase Qty: 1	534661-002
Hex nut Qty: 2	

Subbases available on request

Installation

- The solenoid valves can be mounted in any position without affecting operation
- Pad-mounting solenoid valve supplied with seal

ASCO™ MINIATURE SOLENOID VALVES

FLAPPER FLUID ISOLATION VALVES, 16mm

Dimensions: mm (inches)



Type 01

Solenoid with spade terminals (S0)
DIN 46340
IP40

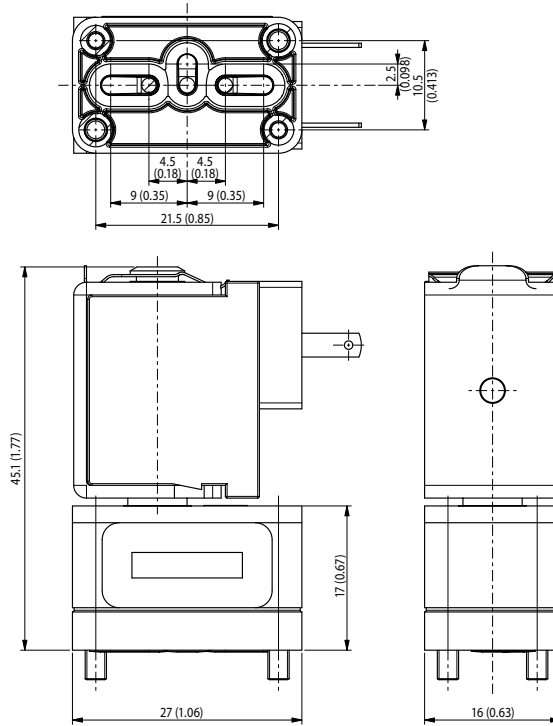

Type 02

Leaded coil (L0)
24 AWG, lead wires:
500mm (19.7in) long
IP66

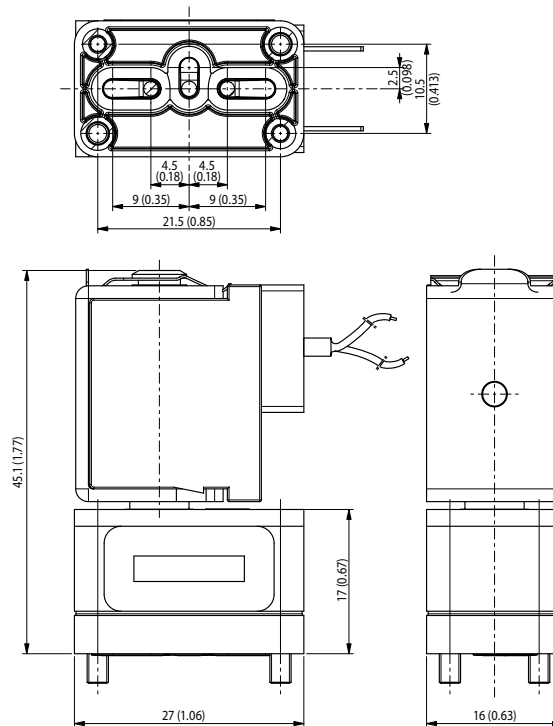

01044GB-2019-R01

Dimensions: mm (inches)

Subbase Mounting Pattern

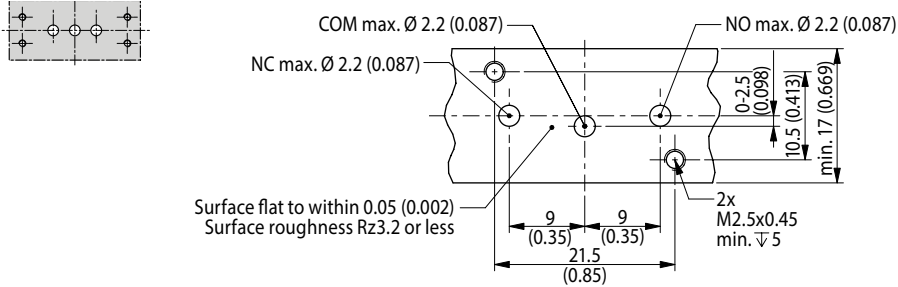

1/4 - 28 UNF Version

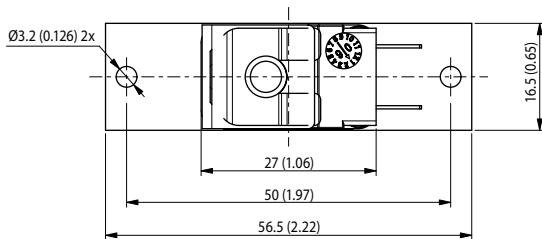
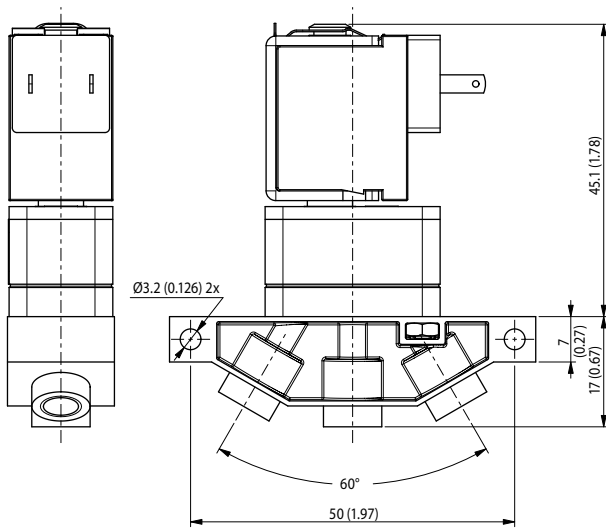

Version with Push-in Hose Connection

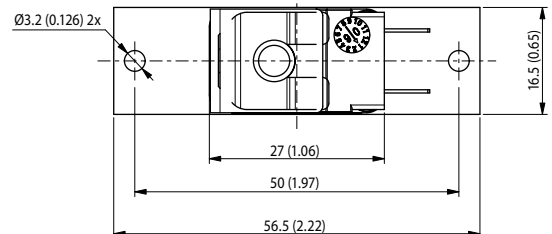
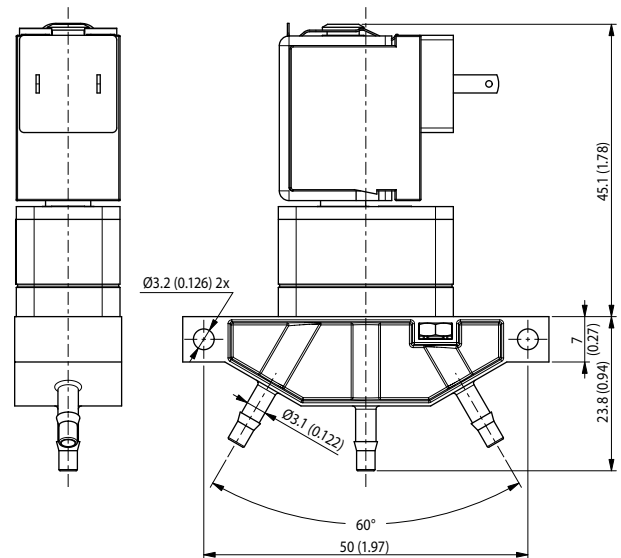

ASCO™ MINIATURE SOLENOID VALVES

FLAPPER SOLENOID FLUID ISOLATION VALVES, 22mm

- Flapper isolation valves are designed for use with neutral or highly aggressive liquids in analytical and medical systems
- Special Flapper mechanism results in no pumping or sticking effects
- Reduced heat transfer between control mechanism and fluid make them ideal for use with heat-sensitive reagents and biological samples
- Hermetic separation of control mechanism prevents particulate contamination caused by friction of moving parts, assuring maximum purity of liquid samples
- Excellent self-draining capability and easy-to-flush low-volume internal cavity make these valves ideal in application where cross-contamination must be minimized
- Meets all relevant CE directives, and is RoHS compliant
- Typical applications include:
 - In-vitro Diagnostics
 - Hematology
 - DNA Sequencing
 - Industrial Liquid Analyzers

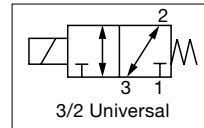
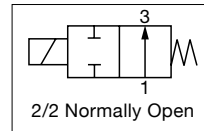
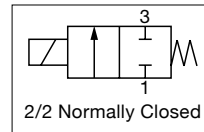

Functional Principle

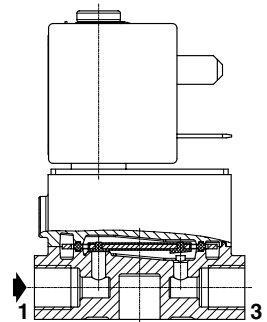

Function 2/2 NC

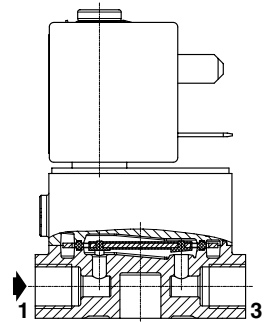

Function 2/2 NO

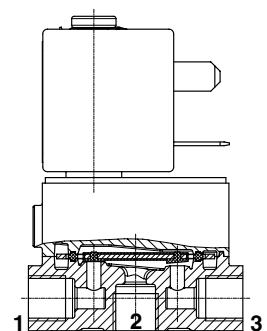

Function 3/2 U

Fluids*	Temperature Range	Seal Materials*
Liquids or Gases ¹	5 °C to 50 °C (41 °F to 122 °F)	FFKM
		FKM
		EPDM

¹ Filtration: 50µm

* Ensure that the compatibility of the materials in contact with the fluids is verified

General Valve Information	
Body	PEEK
Others	Stainless Steel
Response Time	< 10ms
Internal Volume	0.48ml
Max. Viscosity	20 cSt (mm ² /s)

Electrical Characteristics	
Coil Insulation Class	F
Connector	Spade plug (Ø6 to 8mm) or Lead Wires ¹
Connector Specification	DIN 43650, 11mm (0.43in), industry standard B
Electrical Safety	IEC 335 (lead wires: EN 60730)
Electrical Enclosure Protection	Molded IP65 (EN 60529)
Standard Voltages*	12 VDC, 24 VDC (-5%/+10%)

* Other voltages on request

¹ 0.45m (17.7in) lead wires

Prefix Option	Power Ratings			Ambient Temperature Ranges	Replacement Coil		Type ¹
	Inrush	Holding	Hot/Cold		12 VDC	24 VDC	
	VA	VA	W		°C (°F)		
S1	-	-	9.6	5 to 50 (50 to 122)	400129-005	-	01
			10		-	400129-007	
L0	-	-	10	5 to 50 (50 to 122)	400119-011D	400119-008D	02

¹ Refer to the drawings on following pages

01035GB-2019-R01

RECOMMENDATION FOR MAXIMUM DUTY CYCLE

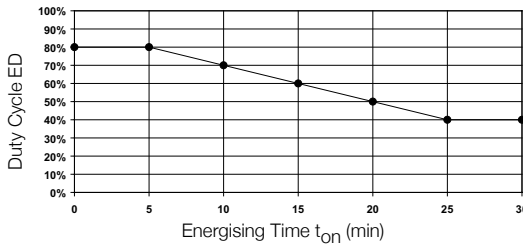

De-energising time: $t_{off} = t_{on} \times (100\% / ED - 1)$

Example:

- 1) Determine energising time in minutes (t_{on}):
 $t_{on} = 15$ min
- 2) Find maximum duty cycle value in diagram:
ED = 60%
- 3) Calculate de-energising time:
 $t_{off} = 15 \text{ min} \times (100\% / 60\% - 1) = 10$ min
- 4) Complete cycle time:
 $t_{cycle} = t_{on} + t_{off} = 15 \text{ min} + 10 \text{ min} = 25$ min

Note: 100% duty cycle possible when using the power-save connector (catalogue number [24 V DC]: 88100934, catalogue number [12 V DC]: 833-150063)

Specifications							
Connection	Orifice Size mm (inches)	Flow Coefficient		Operating Pressure bar (psi)		Power Rating W	Catalog Number Body PEEK
		Kv (m ³ /h)	Cv	min.	max. gases or liquids		
2/2 NC - Normally Closed							
G1/8	2 (0.079)	0.10	0.12	-0.9 (-13)	5 (72.5)	10	G068A317xxx00xx
	3 (0.118)	0.16	0.18	-0.9 (-13)	3 (43)	10	G068A318xxx00xx
	4 (0.157)	0.30	0.35	-0.9 (-13)	1.5 (22)	10	G068A319xxx00xx
Pad Mounting ¹	2 (0.079)	0.10	0.12	-0.9 (-13)	5 (72.5)	10	R068A317xxx00xx
	3 (0.118)	0.16	0.18	-0.9 (-13)	3 (43)	10	R068A318xxx00xx
	4 (0.157)	0.30	0.35	-0.9 (-13)	1.5 (22)	10	R068A319xxx00xx
2/2 NO - Normally Open							
G1/8	2 (0.079)	0.10	0.12	-0.9 (-13)	5 (72.5)	10	G068A327xxx00xx
	3 (0.118)	0.16	0.18	-0.9 (-13)	2 (29)	10	G068A328xxx00xx
	4 (0.157)	0.30	0.35	-0.9 (-13)	1 (14.5)	10	G068A329xxx00xx
Pad Mounting ¹	2 (0.079)	0.10	0.12	-0.9 (-13)	5 (72.5)	10	R068A327xxx00xx
	3 (0.118)	0.16	0.18	-0.9 (-13)	2 (29)	10	R068A328xxx00xx
	4 (0.157)	0.30	0.35	-0.9 (-13)	1 (14.5)	10	R068A329xxx00xx
3/2 U-Universal							
G1/8	2 (0.079)	0.10	0.12	-0.9 (-13)	5 (72.5)	10	G068A337xxx00xx
	3 (0.118)	0.16	0.18	-0.9 (-13)	2 (29)	10	G068A338xxx00xx
	4 (0.157)	0.30	0.35	-0.9 (-13)	1 (14.5)	10	G068A339xxx00xx
Pad Mounting ¹	2 (0.079)	0.10	0.12	-0.9 (-13)	5 (72.5)	10	R068A337xxx00xx
	3 (0.118)	0.16	0.18	-0.9 (-13)	2 (29)	10	R068A338xxx00xx
	4 (0.157)	0.30	0.35	-0.9 (-13)	1 (14.5)	10	R068A339xxx00xx

¹ 4 hexagon socket head cap mounting screws M3 x 8mm (0.31in), stainless steel, ISO 4762 supplied

How to Order

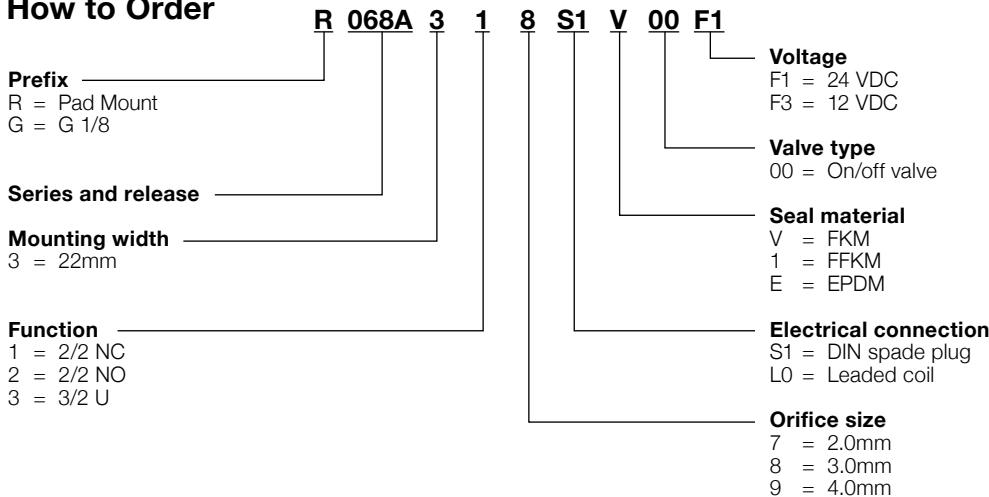

Options

- Subbases available on request
- Power-save connector (2.5 W after 140ms of operation), 24 VDC version: 88100934, 12 VDC version: 833-150063
- Impulse manual operator

Installation

- The solenoid valves can be mounted in any position without affecting operation
- Pad-mounting solenoid valve supplied with seal
- Pipe connections 1/8 have standard thread according to ISO 228/1

ASCO™ MINIATURE SOLENOID VALVES

FLAPPER SOLENOID FLUID ISOLATION VALVES, 22mm

SERIES
068

Dimensions: mm (inches)

Type 01

Solenoid with spade plug connector (S1)
Epoxy molded
IEC 335/DIN 43650
IP65

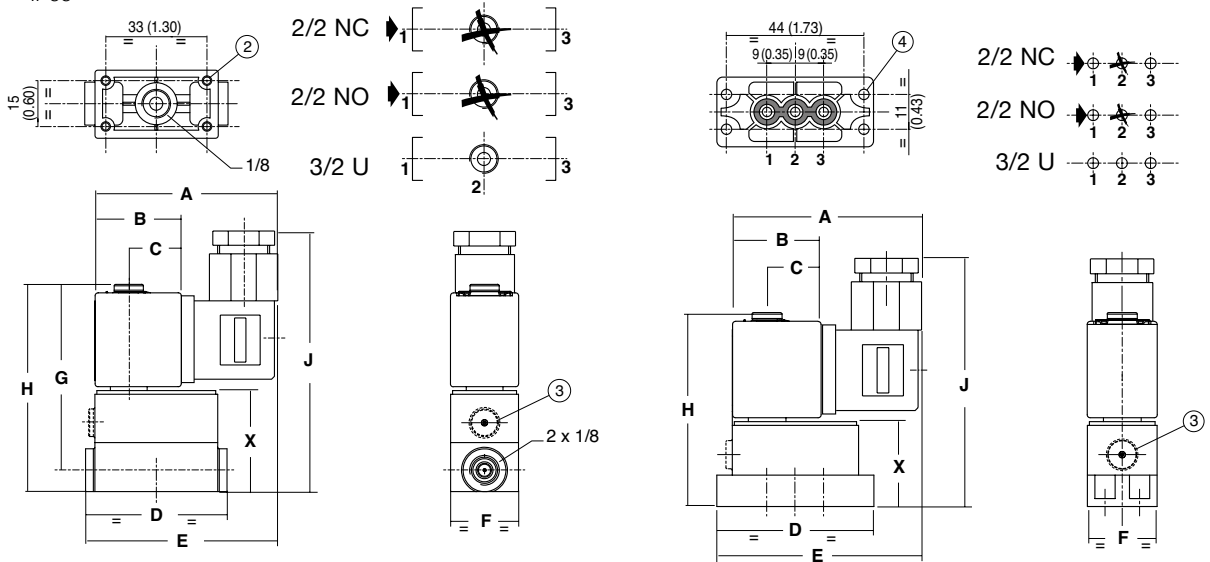

Type 02

Leaded coil (L0)
IEC 335, lead wires:
0.45m (17.7in) long
IP40

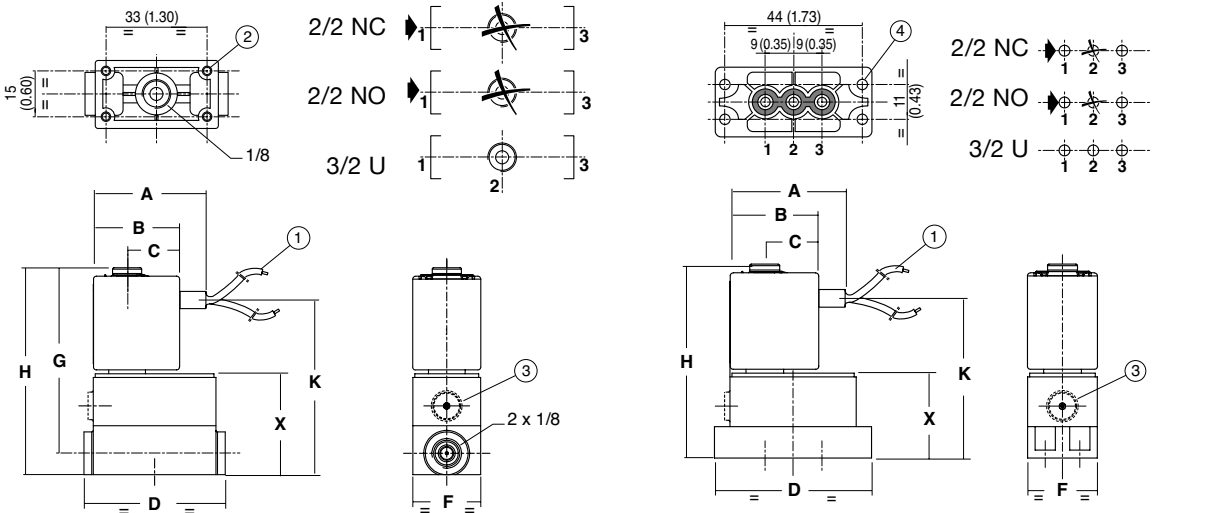

Type	Prefix Option	Catalog Number	A	B	C	D	E	F	G	H	J	K	X	weight kg ¹
01	S1	G068A...S1..	60 (2.36)	28.5 (1.12)	17.5 (0.69)	46.2 (1.82)	62.5 (2.46)	22.3 (0.88)	60.8 (2.40)	67.8 (2.67)	82 (3.23)	-	33 (1.30)	0.130
		R068A...S1..	60 (2.36)	28.5 (1.12)	17.5 (0.69)	50 (1.97)	65 (2.56)	22.3 (0.88)	-	61.8 (2.43)	76 (3.00)	-	27 (1.06)	0.124
02	L0	G068A...L0..	35 (1.38)	28.5 (1.12)	17.5 (0.69)	46.2 (1.82)	-	22.3 (0.88)	60.8 (2.40)	67.8 (2.67)	-	56.5 (2.22)	33 (1.30)	0.124
		R068A...L0..	35 (1.38)	28.5 (1.12)	17.5 (0.69)	50 (1.97)	-	22.3 (0.88)	-	61.8 (2.43)	-	50.5 (1.99)	27 (1.06)	0.120

- ① 2 wires, length 0.45m (17.7in)
- ② 4 mounting holes, max. depth 7mm (0.27in), for self-tapping screw (type EJOT PT, K30)
- ③ Manual operator location
- ④ 4 mounting holes Ø3.2mm (0.126in) (4 hexagon socket head cap mounting screws M3 x 8mm (0.315in), stainless steel, ISO 4762 supplied)

¹ Type 01: includes coil(s) and connector(s); Type 02: with 0.45m (17.7in) lead wires

01035GB-2019-R01

Dimensions: mm (inches)

Subbase Mounting Pattern

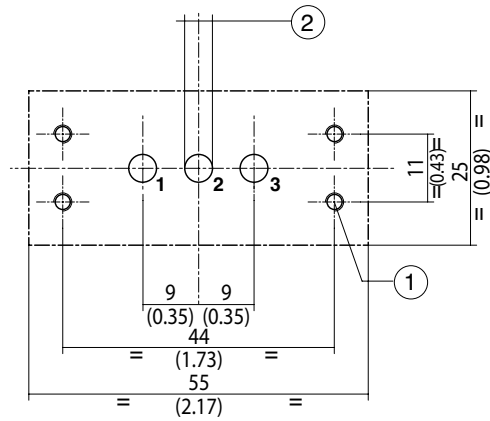
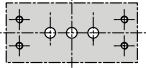

- ① 4 mounting holes Ø3.2mm (0.126in)
- ② Max. diameter 4.5mm (0.177in) 3x



ASCO™ MINIATURE SOLENOID VALVES

ROCKER MECHANISM, FLUID ISOLATION, HOSE CONNECTIONS

- Valves for medical analysers, biotechnology, gas analysers
- Can be used to control acids and bases, as well as analytical reagents
- Any application where the fluid may not come into contact with metal parts and with the electromagnetic control section of the solenoid valves
- The valves are ideal for controlling aggressive fluids or when high purity is demanded and have easy to flush internal cavities
- They can also be used as a very small internal volume flow-through sampling valve due to rocker technology
- Hermetic separation of control mechanism and fluid
- Reduced heat exchange between coil and fluid
- Protected manual operator
- The use of first class materials and thorough valve testing ensure high reliability and a lifetime of at least 1 million cycles
- The solenoid valves satisfy all relevant EC directives
- Typical applications include:
 - Hematology

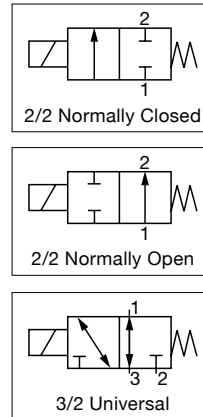

Fluids*	Temperature Range	Seal Materials*
Liquids or gases	0 °C to 40 °C (32 °F to 104 °F)	EPDM (ethylene-propylene)

* Ensure that the compatibility of the materials in contact with the fluids is verified.

General Valve Information*	
Body	PA12
Internal parts	Stainless steel
Diaphragm-poppets	EPDM
Cover	PA12 (transparent), enabling flow of fluid to be seen
Differential pressure	-0.7 to +2 bar (usable in 0.3 bar abs. vacuum) [1 bar =100 kPa]
Maximum viscosity	20 cSt (mm ² /s)
Response Time	< 20ms
Internal Volume	< 75 µl (connections not included)

* Ensure that the compatibility of the materials in contact with the fluids is verified

Electrical Characteristics	
Coil Insulation Class	F
Duty cycle	100%
Coil	Two spade terminals 2.8 x 0.5 mm (DIN 46340)
Electrical Safety	IEC 335
Electrical Enclosure Protection	IP65 (EN60529)
Standard Voltages*	12 VDC, 24 VDC

* Other voltages on request

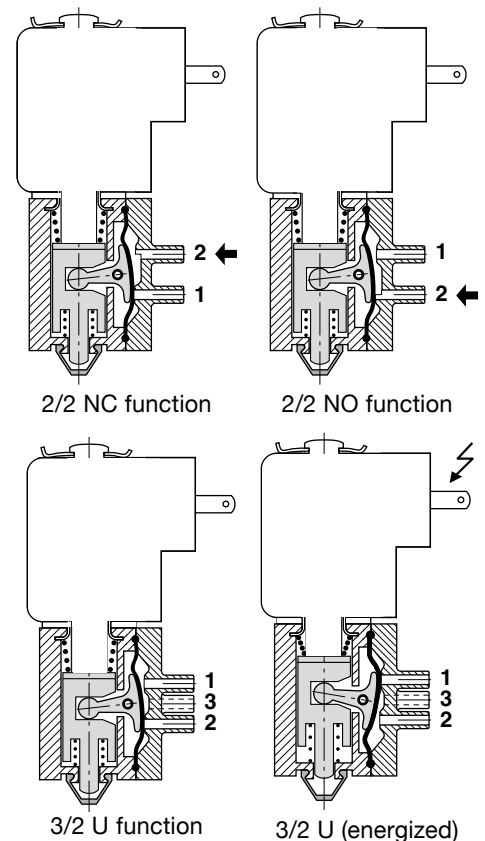

	Power Ratings				Ambient Temperature Ranges °C (°F)	Replacement Coil		Type ¹
	Inrush	Holding	Hot/Cold			-	24 VDC	
	VA	VA	W	W				
	-	-	-	4 / 5	-5 to 40 (23 to 104)	-	43004663	01

¹ Refer to the dimensional drawings on the following page

01004GB-2019-R01

Specifications										
Connection	Orifice Size	Flow Coefficient			Operating Pressure bar (psi)			Power Rating	Catalog Number (protected impulse manual operator)	
					min.	max.			Rear Mounting	central support plate mounting
mm (inches)	Kv (m³/h)	Cv	l/min		gases	liquids	W			
Hose connection to ID 1.5 mm flexible tubing	2/2 NC - Normally closed / 2 connections									
	1.5 (0.059)	0.05	0.058	0.75	-0.7 (-10)	2 (29)	2 (29)	5	11000006	11000010--P2
	2/2 NO - Normally open / 2 connections									
	1.5 (0.059)	0.05	0.058	0.75	-0.7 (-10)	2 (29)	2 (29)	5	11000005--P2	11000009
	3/2 U - Universal / 3 connections									
	1.5 (0.059)	0.05	0.058	0.75	-0.7 (-10)	2 (29)	2 (29)	5	11000007--P2	11000011--P2
3/2 U - Universal / 4 connections										
1.5 (0.059)	0.05	0.058	0.75	-0.7 (-10)	2 (29)	2 (29)	5	11000008	11000012	

How to Order

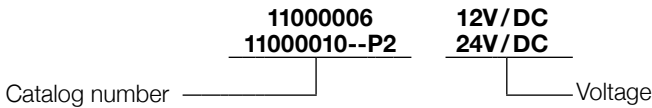

Options

- Stainless steel support plate for mounting between body and coil for:
 - 1 solenoid valve, catalogue number 88211001
 - 2 solenoid valves, catalogue number 88211002
 - 3 solenoid valves, catalogue number 88211003
 - 4 solenoid valves, catalogue number 88211004
 - 5 solenoid valves, catalogue number 88211005
 For more, contact us
- FKM (fluoroelastomer) diaphragm

Installation

- The solenoid valves can be mounted in any position without affecting operation
- Rear or control support plate mounting possible (see below)
- Hose connection of flexible tubing Ø 1.5 mm ID
- Compact size and simple tubing (see following page)
- Replacement coils are available
- Installation/maintenance instructions are included with each valve

ASCO™ MINIATURE SOLENOID VALVES

ROCKER MECHANISM, FLUID ISOLATION, HOSE CONNECTIONS

Dimensions: mm (inches)



TYPE 01
Prefix "SC" Solenoid
DIN 43340

11000005..12

2/2 NC

2/2 NO

3/2 U
(3 connections)

3/2 U
(4 connections)

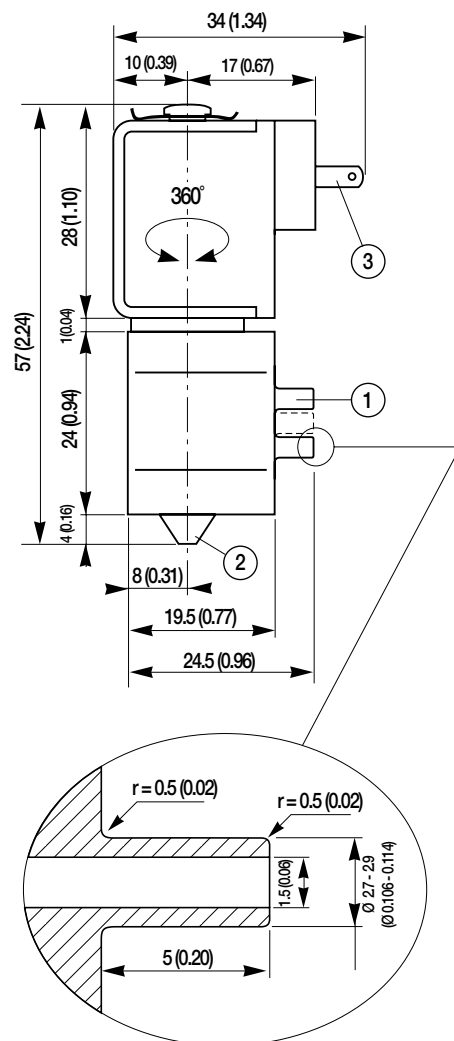
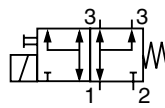
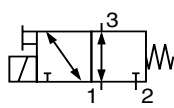
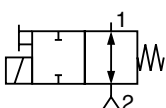
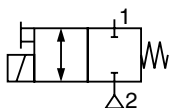
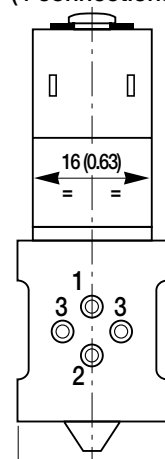
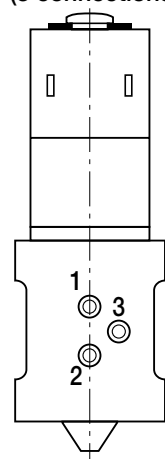
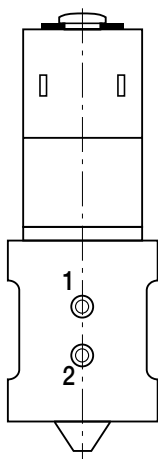
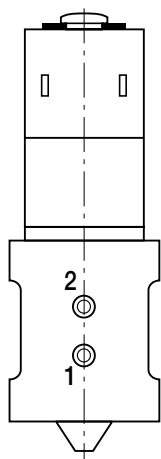

- ① Hose bibs for connection of ID 1.5 mm flexible tubing
- ② Protected impulse type manual operator
- ③ Coil with two spade terminals 2.8 x 0.5 (DIN 46340)

Type	Prefix option	Weight ⁽¹⁾ kg
01	SC	0.46

⁽¹⁾ Incl. coil

Details of hose bib

01004GB-2019-R01

Dimensions: mm (inches)

REAR MOUNTING

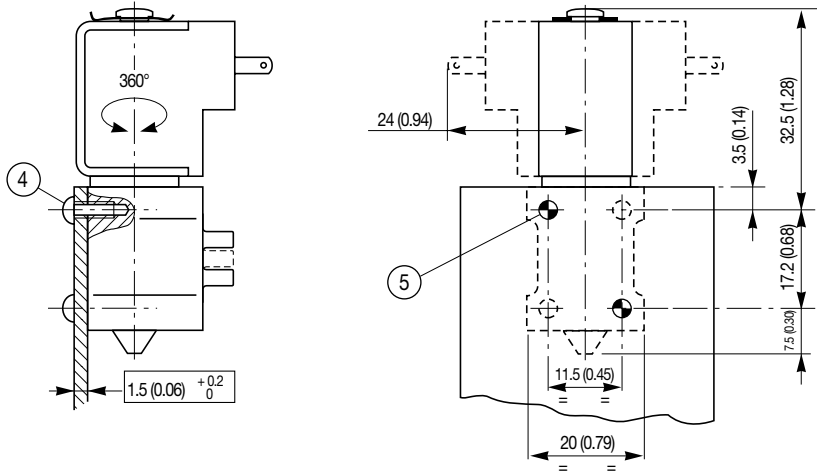

- ④ 2 self thread cutting «Torx» screws
K 22 x 6 - A2 stainless steel
(screws delivered)
- use these screws only
- use plate with correct thickness
- max. torque: 0.3 Nm
- ⑤ Two mounting holes 2.5 mm dia.
Solenoid valve body has four
holes for mounting purpose

SUPPORT PLATE MOUNTING (For solenoid valve of corresponding type)

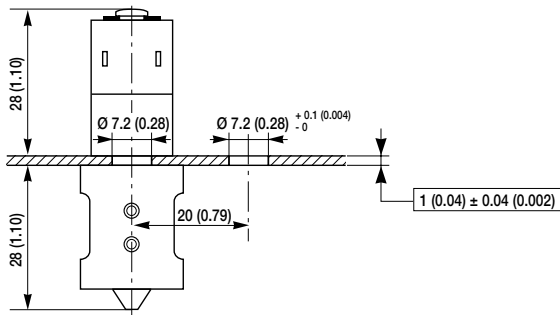

- The panel must be of non-magnetic material.
- To fit to panel, remove the clip and the solenoid valve coil and install as indicated below.

**SUPPORT PLATE
FOR 1 SOLENOID VALVE**

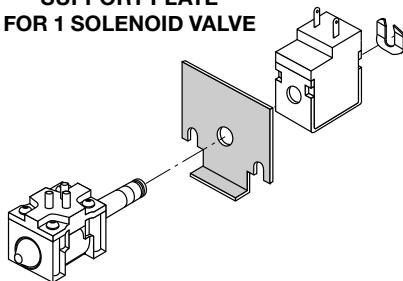

**SUPPORT PLATE
FOR 2 TO 5 SOLENOID VALVES**

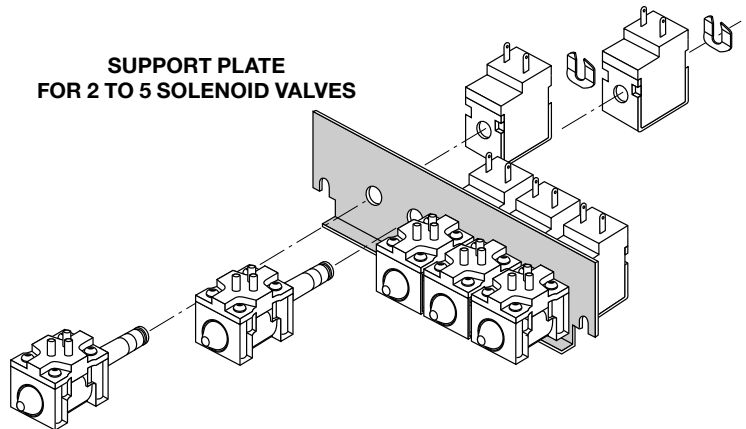

ASCO™ MINIATURE SOLENOID VALVES
ROCKER MECHANISM, FLUID ISOLATION, HOSE CONNECTIONS

SUPPORT PLATE FOR 1 TO 5 SOLENOID VALVES

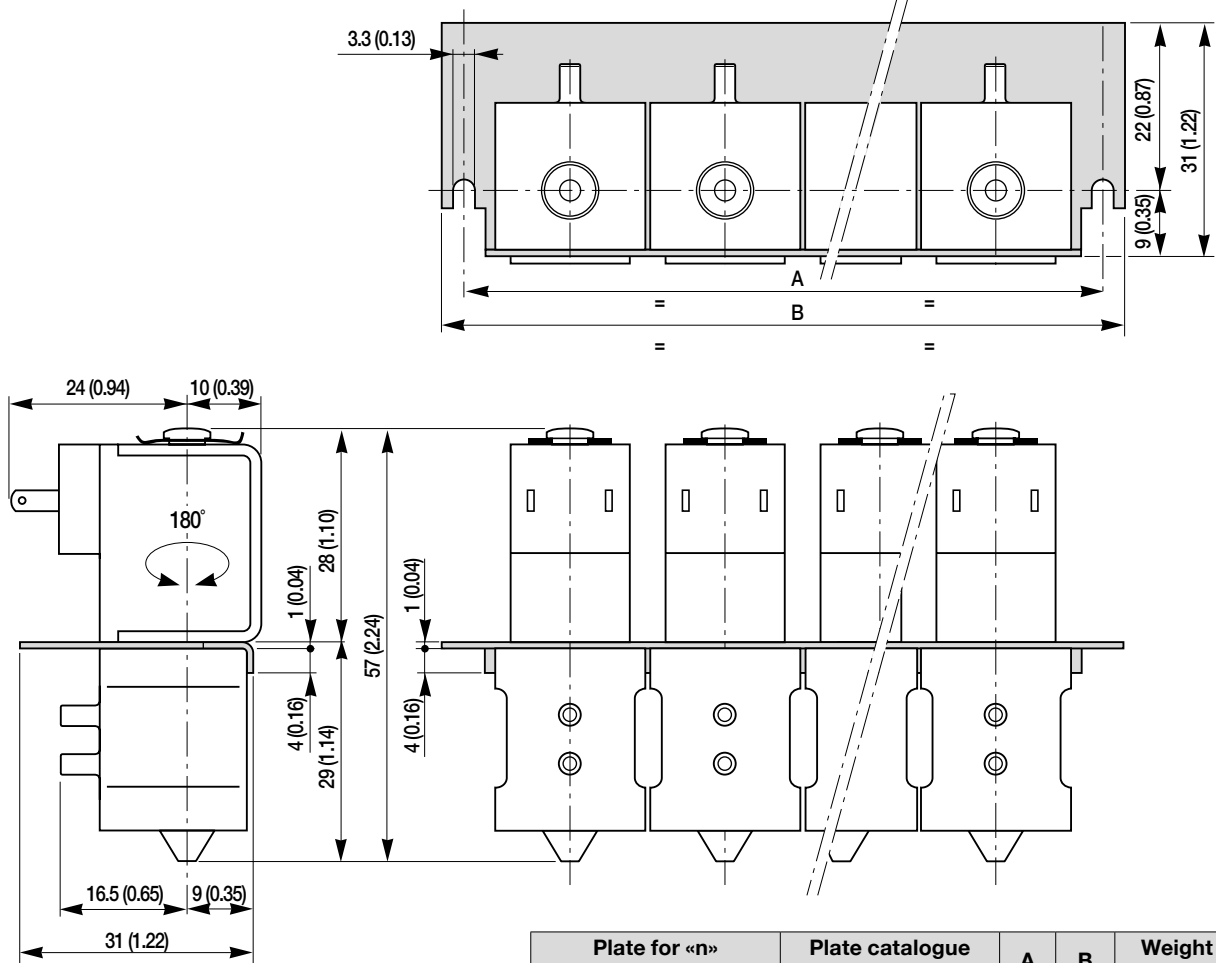
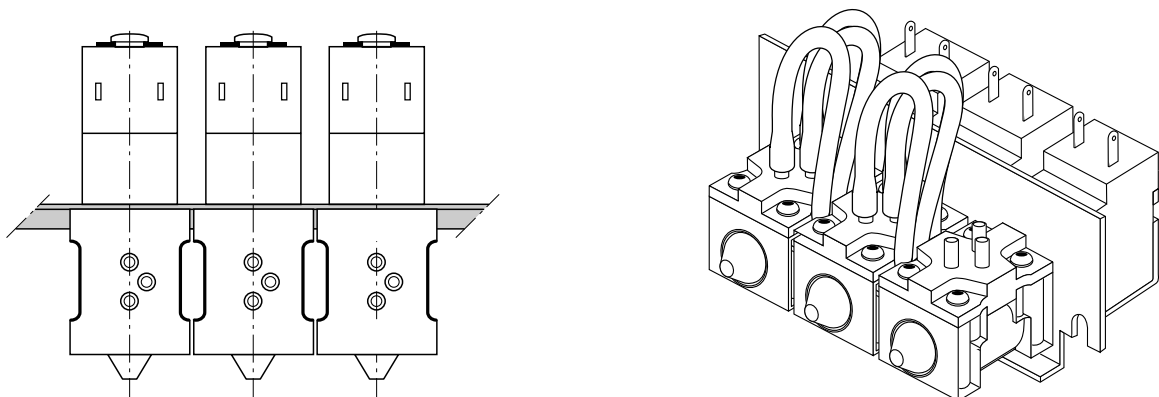

Plate for «n» solenoid valves	Plate catalogue number	A	B	Weight ⁽¹⁾ kg
1	88211001	31	40	0.1
2	88211002	51	60	0.15
3	88211003	72	80	0.2
4	88211004	92	100	0.25
5	88211005	113	121	0.3

⁽¹⁾ Plate only.

SIMPLE TUBING

When valves mounted side by side on a support plate, an area is left open so that tubes pass between valve bodies



01004GB-2019-R01

ASCO™ MINIATURE SOLENOID VALVES

STEPPER MOTOR PINCH VALVES

SERIES
S170-S370

- Stepper motor pinch valve, suitable to shut off media without producing neither turbulent flows, nor dead spaces. Particularly suitable for most of the analytical, medical and food applications.
- If equipped with fitting control electronics, the valve can perform ON-OFF functions, as well as analog input and potentiometer control. The “OPEN” and “CLOSE” positions of the valve will be set as indicated in the section “OPERATING INSTRUCTIONS”.
- The system allows a bi-directional through flow and a high flow rate.
- The valve is suitable for elastic tubings with hardness up to 90 Shore A.
- The tubing (not included in our supply) is the only material in contact with the fluid.
- Typical applications include:
 - Blood analysis devices
 - Sample handling
 - Devices with dynamic regulation

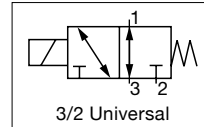
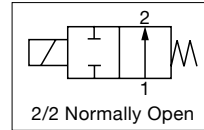
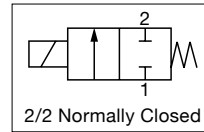

General Valve Information*	
Body	Anodized aluminium
Pinching device	POM (reinforced acetal copolymer)
Engine cover	PA (Polyamide)
Board cover	PA (Polyamide)
Internal components	Brass and Stainless Steel
max. Tube hardness	90 Shore A
Ambient temperature	-10°C +60°C
Minimum step	0.033mm/step

* Ensure that the compatibility of the materials in contact with the fluids is verified.

	Electrical Characteristics	
	Versions without electronic board	Versions with electronic board
Continuous duty	ED 100%	ED 100%
Insulation class	B (130°C)	B (130°C)
Drive methods	1-2 phase	
Drive circuit	bipolar chopper	
Windings resistance	24Ω	
Current / phase	500mA	
Electric connection	Molex pitch 2.54mm 4 pins	Molex pitch 2.54mm 6 pins Molex pitch 2.54mm 2 pins
Protection degree	IP 40 (DIN40050)	IP 40 (EN 60529)

01093GB-2019-R01

Specifications											
Catalog number	Tubing		Pinching strength (N)	Closing speed (mm/s)	Power Rating (W)	Voltage	Operation	LED indicators			
	max. O.D. (mm)	orifice size (mm)						Green	Yellow	Red	Blue
2-way											
S170XA01X0900XX	9.5		up to 80N	3.33	9	12V DC	Wiring	N/A			
2-way On/Off											
S170XA01X1900VU	9.5	6.4	up to 80N	3.33	9	[12%24] V	Wiring	Valve open	Valve closed	Alarm/ Malfunction	Programming mode
S170XA01X2900VU							Analog input (0-5V)	see Operating instructions			
S170XA01X3900VU							Analog input (4-20mA)				
S170XA01X4900VU							Potentiometer	Valve open	Valve closed		
S170XA01X5900VU							Fail saving	Valve open	Valve closed		
2-way normally open											
S170XA01X8900VU	9.5	6.4	up to 80N	3.33	9	[12%24] V	Fail saving controlled via Potentiometer proportional flow control	Valve open	Valve closed	Alarm/ Malfunction	Programming mode
2-way normally closed											
S170XA01X8901VU	9.5	6.4	up to 80N	3.33	9	[12%24] V	Fail saving controlled via Potentiometer proportional flow control	Valve open	Valve closed	Alarm/ Malfunction	Programming mode
S170XA02X1900VU							On/Off				
3-way											
S370XA01X0900XX	9.5		up to 80N	3.33	9	[12%24] V	Wiring	N/A			
3-way On/Off											
S370XA01X1900VU	9.5	6.4	up to 80N	3.33	9	[12%24] V		Upper Tube open Lower Tube closed	Upper Tube closed Lower Tube Open	Alarm/ Malfunction	Programming mode

Dimensions: mm (inches)

S170-XA01X0900XX

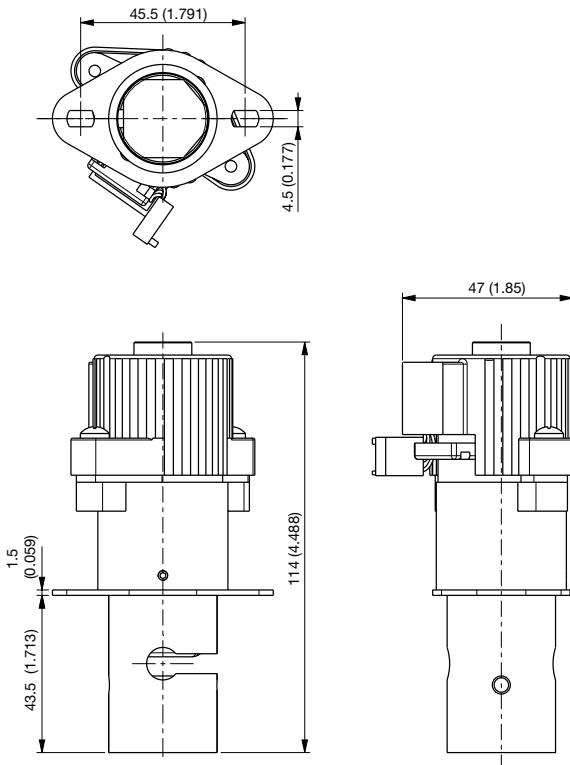

S370-XA01X0900XX

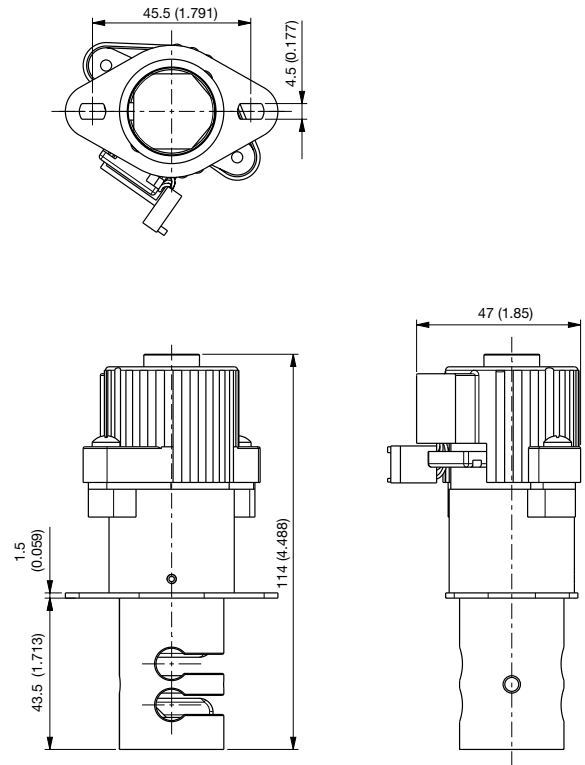

STEPPER MOTOR WIRING

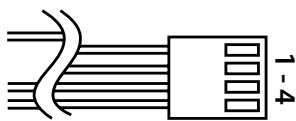

PIN NO.	WIRE COLOR	MOTOR
1	YELLOW	B3
2	ORANGE	B1
3	BROWN	A3
4	BLACK	A1

WIRE COLOUR CODE

CONNECTOR PIN NO.	HEAD SPINDLE IN STEP			
	1	2	3	4
1	+	+	-	-
2	-	-	+	+
3	-	+	+	-
4	+	-	-	+

CONNECTOR PIN NO.	HEAD SPINDLE out STEP			
	1	2	3	4
1	-	-	+	+
2	+	+	-	-
3	-	+	+	-
4	+	-	-	+

Notes

- Some data, e.g. actuating time and power absorption, are directly depending on the electronic control and can vary accordingly
- For the use of a tubing with outside diameter smaller than 6mm, it is necessary to install the tubing guide sleeve (drawing K29501)

01093GB-2019-R01

Dimensions: mm (inches)

S170XA01X1900VU
S170XA01X2900VU
S170XA01X3900VU
S170XA01X4900VU
S170XA01X5900VU
S170XA02X1900VU

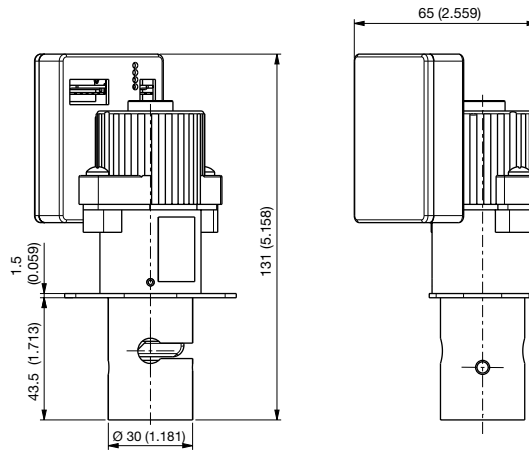
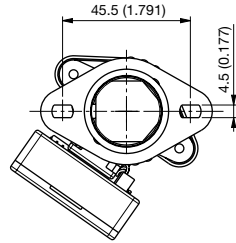

Electrical connection

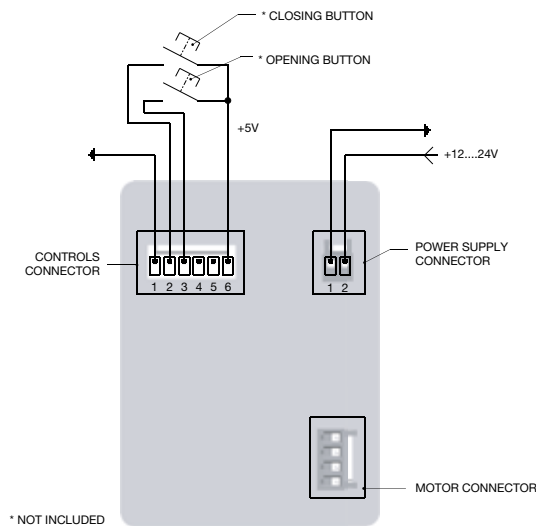

S170XA01X1900VU

Operating Instructions

When power is supplied, the valve will reset (red and green LEDs on) and will automatically move to OPEN position (red LED off).

1. Insert the tube in the respective slot
- The valve is now operational and by providing the opening or closing pulse (minimum 10ms), the valve will act accordingly.

LED signals meaning:

- Green LED on -> Valve open
- Yellow LED on -> Valve closed

Notes

- Valve position fixed on loss of power.
- When the power will be restored, the valve will reset (red and green LEDs on) and will automatically move to OPEN position (red LED off).
- For use with different tubings, the min/max opening of the pinching device can be modified as indicated in the Maintenance Instructions. As an alternative, it is also possible to order the valves already programmed, with the desired strokes.
- Some data, e.g. actuating time and power absorption, are directly depending on the electronic control and can vary accordingly
- Valve position fixed on loss of power. "Fail Saving" function available on demand.

S170XA02X1900VU

Operating Instructions

When power is supplied, the valve will reset (red and green LEDs on) and will automatically move to CLOSED position (red LED off).

1. Give an OPEN command
 2. Insert the tube in the respective slot
- The valve is now operational and by providing the opening or closing pulse (minimum 10ms), the valve will act accordingly.

LED signals meaning:

- Green LED on -> Valve open

Notes

- Valve position fixed on loss of power.
- When the power will be restored, the valve will reset (red and green LEDs on) and will automatically move to CLOSED position (red LED off).

S370XA01X1900VU

Operating Instructions

When power is supplied, the valve will not move and the red LED will be on.

By simultaneously providing the opening and closing pulses, the valve will reset (red, yellow and green LEDs on) and will automatically move to OPEN position (red and yellow LEDs off).

1. Insert the tube in the upper slot
2. Provide a closing command and insert the tube in the lower slot

The valve is now operational and by providing the opening or closing pulse (minimum 10ms), the valve will act accordingly.

LED signals meaning:

- Green LED on -> upper slot open – lower slot closed
- Yellow LED on -> upper slot closed – lower slot open

Notes

- Valve position fixed on loss of power.
- When the power will be restored, the valve will not move and the red LED will be on.
- Remove the tube from the lower slot. If the current position of the valve makes it difficult to remove the tube, use the closing command to facilitate this operation. During this phase, the yellow and red LEDs will be on.
- After removing the tube, provide simultaneously the opening and closing pulses, so that the valve resets (red, yellow and green LEDs on). This way, the valve will automatically move to OPEN position (red and yellow LEDs off). Perform a closing command and insert the tube in the lower slot.

01093GB-2019-R01

Electrical connection

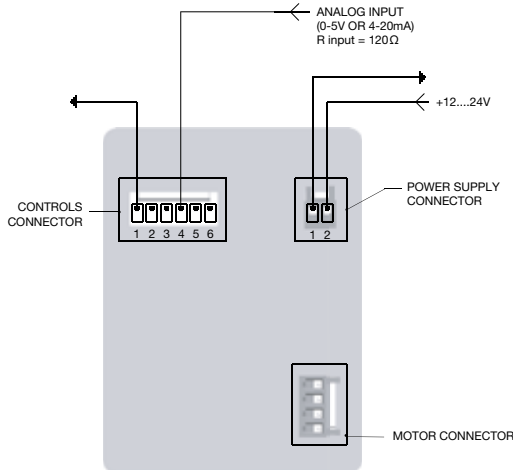

S170XA01X2900VU
S170XA01X3900VU

Operating Instructions

When power is supplied, the valve will reset (red and green LEDs on) and will automatically move to CLOSED position.

Depending on the version, there will be:

- a. green LED on and yellow LED flashing for the “voltage version” [0 ÷ 5]V
- b. yellow LED on and green LED flashing for the “current version” [4 ÷ 20]mA.

1. Depending on the chosen version, supply 5V or 20mA input to have a complete opening of the valve.
2. Insert the tube in the respective slot

The valve is now operational and by providing a [4 ÷ 20]mA or a [0 ÷ 5]V signal (depending on the chosen version), the valve will act accordingly.

LED signals meaning:

- green LED on and yellow LED flashing -> analogic input on (“voltage version”)
- yellow LED on and green LED flashing -> analogic input on (“current version”)

Notes

- Valve position fixed on loss of power.
- When the power will be restored, the valve will reset (red and green LEDs on) and will automatically move to the position set by the input analog signal.
- For use with different tubings, the min/max opening of the pinching device can be modified as indicated in the Maintenance Instructions. As an alternative, it is also possible to order the valves already programmed, with the desired strokes.
- Some data, e.g. actuating time and power absorption, are directly depending on the electronic control and can vary accordingly
- Valve position fixed on loss of power. “Fail Saving” function available on demand.

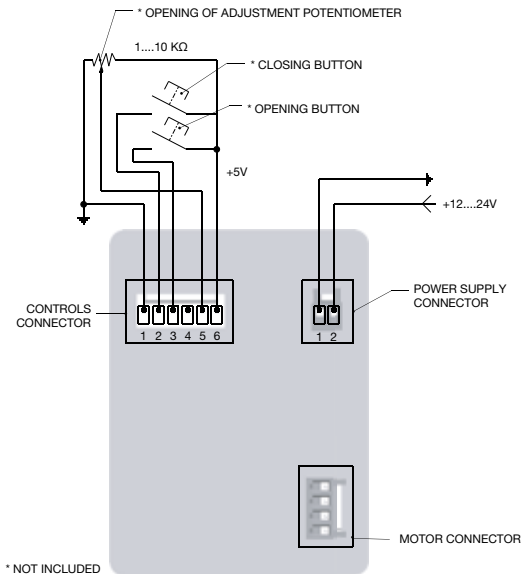

S170XA01X4900VU

Operating Instructions

When power is supplied, the valve will reset (red and green LEDs on) and will automatically move to OPEN position (red LED off).

If the position of the potentiometer doesn't allow a complete opening of the valve (the yellow LED will be on, in addition to the red and green ones), adjust the potentiometer so as to have a complete opening.

1. Insert the tube in the respective slot

The valve is now operational and by providing the opening or closing pulse (minimum 10ms), the valve will act accordingly.

LED signals meaning:

- Green LED on -> Valve open*
- Yellow LED on -> Valve closed

*the opening degree is controlled by the position of the potentiometer.

Notes

- Valve position fixed on loss of power. When the power will be restored, the valve will reset (red and green LEDs on) and will automatically move to OPEN position (red LED off). If the potentiometer is not in complete opening position, the yellow LED will be on.
NB: With the open valve, it will be possible to adjust the opening degree according to your needs, by adjusting the potentiometer.
- For use with different tubings, the min/max opening of the pinching device can be modified as indicated in the Maintenance Instructions. As an alternative, it is also possible to order the valves already programmed, with the desired strokes.
- Some data, e.g. actuating time and power absorption, are directly depending on the electronic control and can vary accordingly
- Valve position fixed on loss of power. “Fail Saving” function available on demand.

Electrical connection

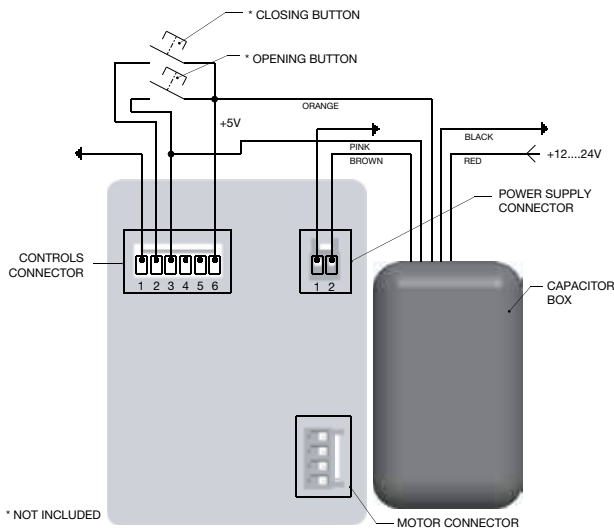

S170XA01X5900VU

Operating Instructions

When power is supplied, the valve will be in OPEN position (green LED on).

1. Insert the tube in the respective slot

The valve is now operational and by providing the opening or closing pulse (minimum 10ms), the valve will act accordingly.

LED signals meaning:

- Green LED on -> Valve open
- Yellow LED on -> Valve closed

Notes

- The valve, being normally open on loss of power (through the condenser block), will move to OPEN position.
- For use with different tubings, the min/max opening of the pinching device can be modified as indicated in the Maintenance Instructions. As an alternative, it is also possible to order the valves already programmed, with the desired strokes.
- Some data, e.g. actuating time and power absorption, are directly depending on the electronic control and can vary accordingly

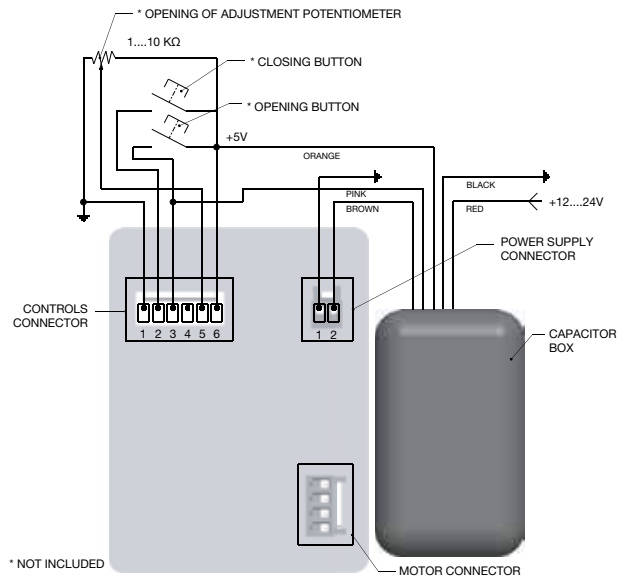

S170XA01X8900VU S170XA01X8901VU

Operating Instructions

When power is supplied, the valve will reset (red and green LEDs on) and will automatically move to OPEN position (red LED off).

If the position of the potentiometer doesn't allow a complete opening of the valve (the yellow LED will be on, in addition to the red and green ones), adjust the potentiometer so as to have a complete opening.

1. Insert the tube in the respective slot

The valve is now operational and by providing the opening or closing pulse (minimum 10ms), the valve will act accordingly.

LED signals meaning:

- Green LED on -> Valve open*
- Yellow LED on -> Valve closed

*the opening degree is controlled by the position of the potentiometer.

Notes

- The normally closed valve will, in case of loss of power (through the capacitor box), move to CLOSED position. The normally open valve will, in case of loss of power (through the capacitor box), move to OPEN position*. NB: With the open valve, it will be possible to adjust the opening degree according to your needs, by adjusting the potentiometer.
- For use with different tubings, the min/max opening of the pinching device can be modified as indicated in the Maintenance Instructions. As an alternative, it is also possible to order the valves already programmed, with the desired strokes.
- Some data, e.g. actuating time and power absorption, are directly depending on the electronic control and can vary accordingly

ASCO™ MINIATURE SOLENOID VALVES

LEVER SOLENOID FLUID ISOLATION VALVES

- Lever mechanism isolation valves designed for use with aggressive and corrosive liquids and gases in analytical instrumentation and the chemical manufacturing industries
- Large orifice sizes make these valves ideal for high flow-rate and high pressure applications
- Ideally suited for quickly flushing systems of corrosive media and routing aggressive reagents to chemical reaction vessels and waste containers
- Available in both a 2-Way normally closed and normally open versions, as well as 3-Way normally closed, normally open and universal versions; each with multiple connection options
- Meets all relevant CE directives, and is RoHS compliant
- Typical applications include:
 - Raw-material Chemical Manufacturing
 - Pharmaceutical
 - Chip/Wafer Manufacturing
 - Waste Water Treatment

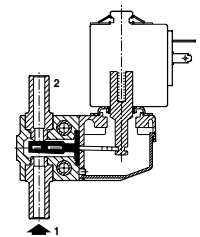
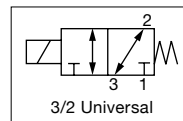
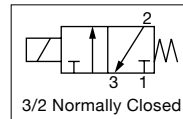
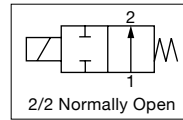
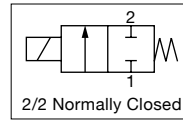

2/2 NC Function

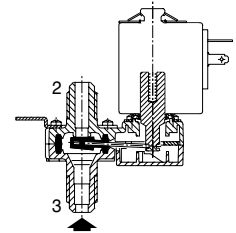

2/2 NC Function

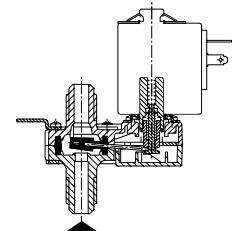

2/2 NO Function

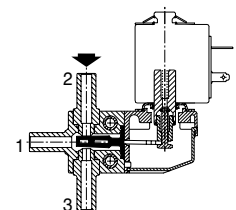

3/2 NC Function

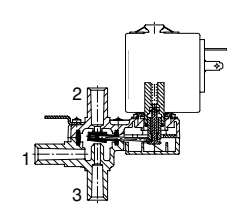

3/2 U Function

Fluids*	Temperature Range	Seal Materials*
Air, Inert Gases, Filtered Water, Oil or Liquids	-10 °C to 100 °C (14 °F to 212 °F)	VMQ (silicone) FKM (fluoroelastomer) EPDM (ethylene-propylene)

* Ensure that the compatibility of the materials in contact with the fluids is verified

General Valve Information		
Body	PEI (polyetherimide)	G 1/2: PPS (polypropylene sulphide)
Response Time	~ 25ms	
Max. Viscosity	37 cSt (mm ² /s)	

Electrical Characteristics	
Coil Insulation Class	F
Connector	Spade plug (cable Ø6-8mm or Ø6-10mm)
Connector Specification	with coil 6W/6W (BMX) DIN 43650, 11mm, industry standard B, with coil 8W/9W (AMX) ISO 4400/EN 175301-803, form A
Electrical Safety	IEC 335
Electrical Enclosure Protection	Molded IP65 (EN 60529)
Standard Voltages ¹	12 VDC, 24 VDC AC ~: 24 V to 115 V to 230 V/50 Hz (BMX = 50 – 60 Hz)

¹ Other voltages and 60 Hz available on request

Prefix Option	Power Ratings				Ambient Temperature Range °C (°F)	Replacement Coil		Type ¹
	Inrush VA	Holding VA	Hot/ Cold W			230 V/50 Hz	24 VDC	
			W	W				
SC	16	10	6	6	-10 to 60 (14 to 40)	43005164	43005149	01 (BMX)
	23	14	8	9	-10 to 60 (14 to 40)	43005149	43005144	02 (AMX)
	44	24	8	13	-10 to 60 (14 to 40)	43005320	43005317	03 (FNX)

¹ Refer to the dimensional drawings on the following page

01021GB-2019-R01

Specifications												
Spigot O.D.	Pipe connection	Orifice Size	Flow coefficient		Operating Pressure bar (psi)			Power Rating (W)		Catalog number	Options	
			Kv (m³/h)	Cv	min.	max.		~	=		FKM	EPDM
mm (inches)		mm (inches)				inert gases	liquids					
2/2 NC - Normally closed, VMQ Seals												
8 (0.31)	-	2.7 (0.11)	0.23	0.27	0	5 (72.5) [10/145]	5 (72.5)	6	6	SCH283A003	V	E
8 (0.31)	-	3.4 (0.13)	0.30	0.35	0	3 (43.5) [6/87]	3 (43.5)	6	6	SCH283A004	V	E
11 (0.43)	-	5.5 (0.22)	0.55	0.64	0	1.5 (21.8)	1 (14.5)	8	9	SCH283A010	-	-
-	G 1/4	3.2 (0.13)	0.32	0.37	0	1.5 (21.8)	1.5 (21.8)	8	9	SCG283A013	-	-
-	G 1/4	5.5 (0.22)	0.55	0.64	0	1.5 (21.8)	1 (14.5)	8	9	SCG283A014	-	-
2/2 NC - Normally closed, EPDM Seals												
11 (0.43)	-	5.5 (0.22)	0.55	0.64	0	4.5 (65.3)	1 (14.5)	8	9	SCH283A008E	V	-
-	G 1/4	3.2 (0.13)	0.32	0.37	0	10 (145)	2.4 (34.81)	8	9	SCG283A011E	V	-
-	G 1/4	5.5 (0.22)	0.55	0.64	0	4.5 (65.3)	1 (14.5)	8	9	SCG283A012E	V	-
-	G 1/2	10 (0.394)	1.6	1.85	0	1.6 (23.2)	0.25 (3.63)	13	13	SCG283C006E	V	-
2/2 NO - Normally open, VMQ Seals												
8 (0.31)	-	3.4 (0.13)	0.30	0.35	0	3 (43.5) [6/87]	3 (43.5)	6	6	SCH283A016	V	E
2/2 NO - Normally open, FKM Seals												
11 (0.43)	-	5.5 (0.22)	0.55	0.64	0	1.5 (21.8)	1 (14.5)	8	9	SCH283A018V	-	-
3/2 NC - Normally closed, VMQ Seals												
8 (0.31)	-	3.4 (0.13)	0.30	0.35	0	1 (14.5)	1 (14.5)	6	6	SCH383A003	V	E
3/2 NO - Normally open, FKM Seals												
8 (0.31)	-	3.4 (0.13)	0.30	0.35	0	2.5 (36.2)	2 (29)	6	6	SCH383A004V	-	-
-	G 1/2	9 (0.35)	1.6	1.85	0	0.4 (5.8)	-	13	-*	SCG383C006	-	-
3/2 NO - Normally open, EPDM Seals												
8 (0.31)	-	3.4 (0.13)	0.30	0.35	0	2.5 (36.2)	2 (29)	6	6	SCH383A004E	-	-
3/2 U - Universal, VMQ Seals												
11 (0.43)	-	3.2 (0.12)	0.28	0.32	0	1.5 (21.8)	1.5 (21.8)	8	9	SCH383A007	V	E
-	G 1/4	3.2 (0.12)	0.28	0.32	0	1.5 (21.8)	1.5 (21.8)	8	9	SCG383A008	V	E

* AC Version available only
[] Value for pressure with FKM and EPDM seals

How to Order

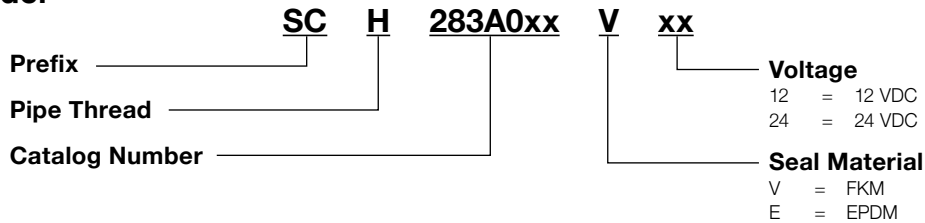

ASCO™ MINIATURE SOLENOID VALVES

LEVER SOLENOID FLUID ISOLATION VALVE

SERIES
283/383

Dimensions: mm (inches)



TYPE 01
Prefix "SC" Solenoid
DIN 43650



TYPE 02
Prefix "SC" Solenoid
ISO 4400

SCH283A003/A004/A016

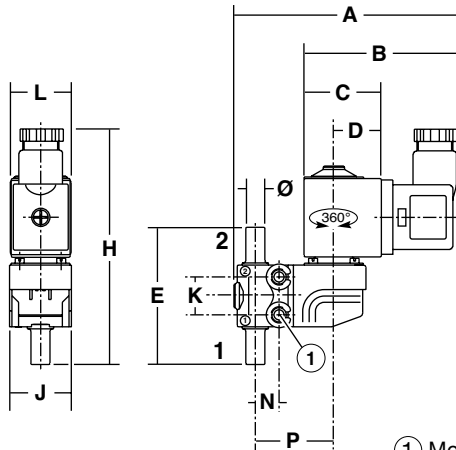

SCH283A010/A008/A018V

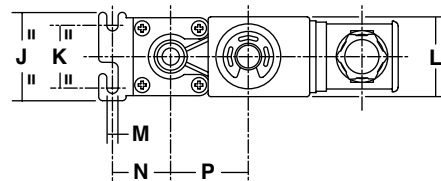
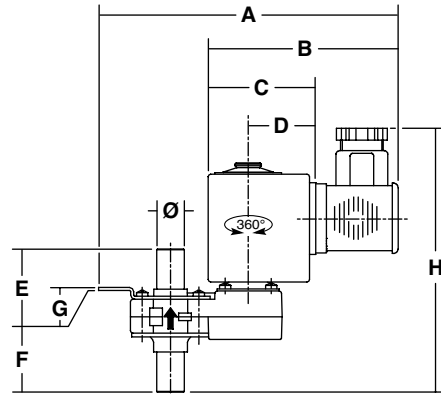

① Mounting: 2 holes
4.3mm (0.17in)

Pressure inlet:

NC function: orifice 1 (type 01) or arrow on body (type 02)
NO function: orifice 2 (type 01) or arrow on body (type 02)

Type	Prefix Option	Catalog Number	A	B	C	D	E	F	G	H	J	K	L	M	N	P	Weight ² kg
01	SC	SCH283A003/A004	94	64.5	33.5	21	58	-	-	97	26	16	25	-	10	33	0.170
		SCH283A016	(3.7)	(2.54)	(1.32)	(0.83)	(2.28)	-	-	(3.82)	(1.02)	(0.63)	(0.98)	-	(0.39)	(1.30)	0.200
02	SC	SCH283A010/A008E/018V	121.5	78	43	27	16.5	40.5	1.2	105	35	25	32	4.5	23	31	0.285
			(4.78)	(3.07)	(1.69)	(1.06)	(0.65)	(1.59)	(0.047)	(4.13)	(1.38)	(0.98)	(1.26)	(0.18)	(0.91)	(1.22)	

² Including coil(s) and connector(s)

01021GB-2019-R01

Dimensions: mm (inches)



TYPE 01
Prefix "SC" Solenoid
ISO 4400

**SCG283A011/012/
013/014/019V**

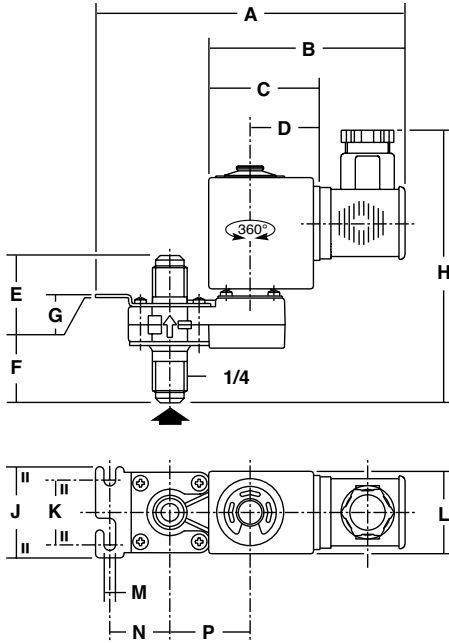

TYPE 02
Prefix "SC" Solenoid
ISO 4400

SCG283C006

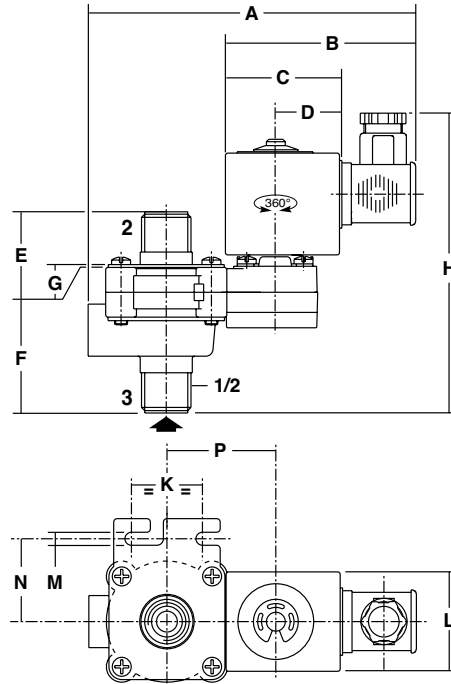

Pressure inlet:

NC function: arrow on body (type 01) or orifice 3 (type 02)
NO function: arrow on body (type 01)

Type	Prefix Option	Catalog Number	A	B	C	D	E	F	G	H	J	K	L	M	N	P	Weight ² kg
01	SC	SCG283A011E/ 012E/013/014/019V	121.5 (4.78)	78 (3.07)	43 (1.69)	27 (1.06)	16.5 (0.65)	40.5 (1.59)	1.2 (0.047)	105 (4.13)	35 (1.38)	25 (0.98)	32 (1.26)	4.5 (0.177)	23 (0.906)	31 (1.22)	0.285
02	SC	SCG283C006E	142.5 (5.61)	84 (3.31)	49 (1.93)	28 (1.10)	23.5 (0.93)	61.5 (2.42)	1.2 (0.047)	128 (5.04)	-	30 (1.18)	42 (1.65)	5.5 (0.217)	35 (1.38)	46 (1.81)	0.57

² Including coil(s) and connector(s).

ASCO™ MINIATURE SOLENOID VALVES

LEVER SOLENOID FLUID ISOLATION VALVE

SERIES
283/383

Dimensions: mm (inches)



TYPE 01
Prefix "SC" Solenoid
DIN 43650



TYPE 02
Prefix "SC" Solenoid
ISO 4400

SCH383A003 / A004V / A004E

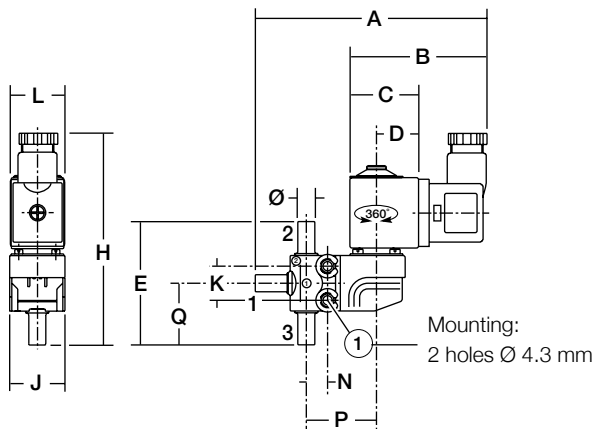

SCH383A007

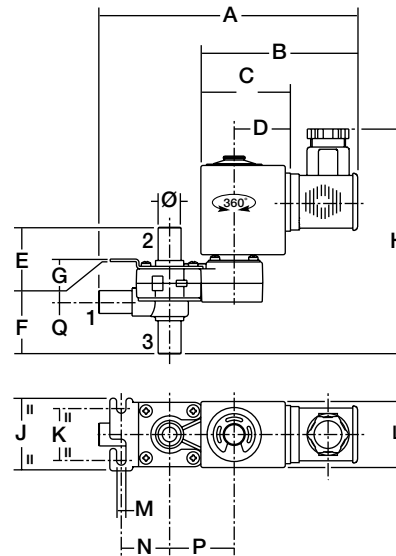

Pressure inlet:

- NC function: orifice 2 (type 01)
- NO function: orifice 3 (type 01)
- U function: all orifices (type 02)

Type	Prefix Option	Catalogue number	A	B	C	D	E	F	G	H	J	K	L	M	N	P	Q	Weight ² kg
01	SC	SCH383A003/A004V/A004E	111 (4.37)	64.5 (2.54)	33.5 (1.32)	21 (0.83)	58 (2.28)	-	-	97 (3.82)	26 (1.02)	16 (0.63)	25 (0.98)	-	10 (0.39)	33 (1.30)	29 (1.14)	0.200
02	SC	SCH383A007	127 (5.0)	78 (3.07)	43 (1.69)	27 (1.06)	16.5 (0.65)	40.5 (1.59)	1.2 (0.05)	105 (4.13)	35 (1.38)	25 (0.98)	32 (1.26)	4.5 (0.18)	23 (0.91)	31 (1.22)	19.5 (0.77)	0.345

² Including coil(s) and connector(s).

01021GB-2019-R01

Dimensions: mm (inches)



TYPE 01
Prefix "SC" Solenoid
ISO 4400

SCG383A008



TYPE 02
Prefix "SC" Solenoid
ISO 4400

SCG383C006

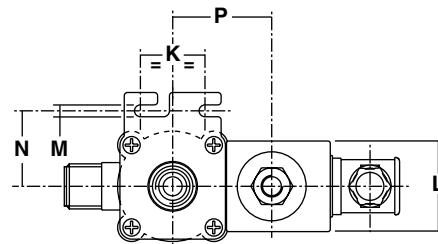
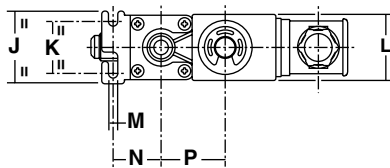
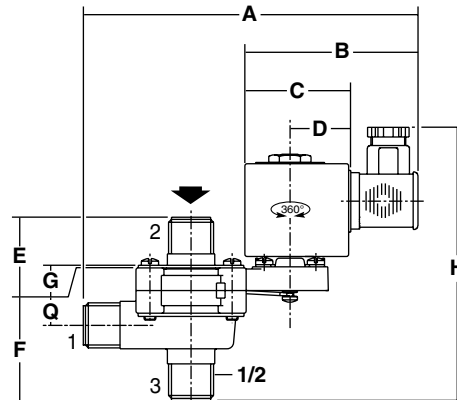
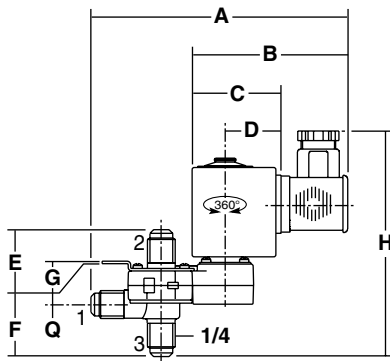

Type	Prefix option	Catalogue number	A	B	C	D	E	F	G	H	J	K	L	M	N	P	Q	Weight ² kg
01	SC	SCG383A008	127 (5.0)	78 (3.07)	43 (1.69)	27 (1.06)	16.5 (0.65)	44.5 (1.75)	1.2 (0.05)	109 (4.29)	35 (1.38)	25 (0.98)	32 (1.26)	4.5 (0.18)	23 (0.91)	31 (1.22)	19.5 (0.77)	0.345
02	SC	SCG383C006	159 (6.26)	84 (3.31)	49 (1.93)	28 (1.10)	23.5 (0.93)	61.5 (2.42)	1.2 (0.05)	128 (5.04)	-	30 (1.18)	42 (1.65)	5.5 (0.22)	35 (1.38)	46 (1.81)	26.5 (1.04)	0.51

² Including coil(s) and connector(s).

Options

- Valves can also be supplied with FKM (fluoroelastomer) and EPDM (ethylene-propylene) seals.
- Plug with visual indication and peak voltage suppression or with cable length of 2m (78.7in)

Installation

- The solenoid valves can be mounted in any position without affecting operation. For optimum performance mount solenoid vertical and upright
- Replacement coils are available: BMX: DC: 12 V, cat. no.: **43005158** /AC: 24 V, cat. no.: **43005161**; 115 V, cat. no.: **43005162** AMX: DC: 12 V, cat. no.: **43005143**/AC: 24 V, cat. no.: **43005146**; 115 V, cat. no.: **43005147**

ASCO™ MINIATURE SOLENOID VALVES

PINCH VALVES, COMPACT 2-WAY SOLENOID

- The 284 Series are 2-Way normally closed and normally open solenoid operated pinch valves designed for use with highly aggressive or high-purity liquids in analytical and medical instrumentation, and industrial applications
- Hermetic separation of control mechanism and the fluid within the tubing prevents particulate contamination caused by friction of moving parts, assuring maximum purity of liquids
- Removable and rotatable electrical coils allow for easy installation and worry-free maintenance
- Bi-directional flow for exceptional versatility
- Available in a large range of body sizes to accommodate a wide variety of tubing sizes
- Meets all relevant CE directives, and is RoHS compliant
- Typical applications include:
 - Hemodialysis
 - Urinary Collection Systems
 - Intravenous (IV) Systems
 - Drug Dispensing

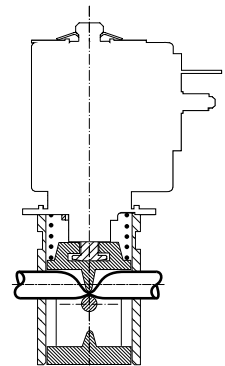
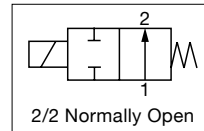
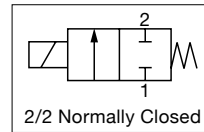

2/2 Normally Closed

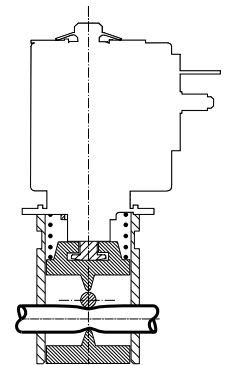

2/2 Normally Open

Fluids*	Temperature Range
Air, Inert Gases, Water, Oil or Liquids	0 °C to 50 °C (32 °F to 122 °F)

* Ensure that the compatibility of the materials in contact with the fluids is verified

General Valve Information*		
Body	Aluminum, anodized	POM (Graphite-reinforced polyacetal)
Pinch Mechanism	POM (Graphite-reinforced polyacetal)	
Others	Stainless Steel	
Guide Tube	Nickel-plated brass	
Coil frame		Galvanized steel
Recommended Tubing	VMQ (silicone) (max. Hardness: 50 Shore A) Tubing not supplied with valve	VMQ (silicone) (max. Hardness: 50 Shore A) 30cm (12in) tubing supplied with valve

* Ensure that the compatibility of the materials in contact with the fluids is verified

Electrical Characteristics		
	Aluminium Body	POM Body
Coil Insulation Class	F	A
Connector	Spade plug; cable Ø4-6mm (0.16-0.24in), Ø6-10mm (0.24-0.40in)	305mm (12in) Lead Wires
Connector Specification	4 W (DNX-4) DIN 43650, 9.4mm (0.37in), industry standard B 6 W/13 W (AMX/FNX) ISO 4400/EN 175301-803, form A	
Electrical Safety	IEC 335	IEC 335
Electrical Enclosure Protection	Coil type 01 = IP65 Coil type 02-03 = IP65	IP30 (EN 60529)
Standard Voltages ¹	12 VDC, 24 VDC	12 VDC, 24 VDC
Power Consumption	4 W, 9 W, 13 W	2.8 W
Response Time	< 20ms	<10 ms

¹ Other voltages on request

Prefix Option	Power Ratings			Ambient Temperature Ranges	Replacement Coil		Type 2	
	Inrush	Holding	Hot/Cold		12 VDC	24 VDC		
	VA	VA W	W					
SC	-	-	-	4	-10 to 60 (14 to 140)	43005268	43005269	01 (DNX-4)
				9		43005143	43005144	02 (AMX)
				13		43005316	43005317	03 (FNX)
				2.8		-	-	-

² Refer to the dimensional drawings on the following page

01085GB-2019-R01

Specifications										
Tube I.D.	Tube O.D.	Pinch Force	Operating Pressure bar (psi)			Power Rating	Catalog Number			
			min.	max.			Aluminium	POM		24 VDC
mm (inches)	mm (inches)	daN		air, inert gas	liquids	W				
2/2 NC - Normally Closed										
0.76 (0.030)	1.65 (0.065)	0.18	0	0.8 (11.6)	0.8 (11.6)	-	4	SCH284B001	-	-
1.02 (0.040)	2.16 (0.085)	0.22	0	0.8 (11.6)	0.8 (11.6)	-	4	SCH284B002	-	-
1.57 (0.062)	3.18 (0.125)	0.28	0	0.8 (11.6)	0.8 (11.6)	-	4	SCH284B003	-	-
1.98 (0.078)	3.18 (0.125)	0.25	0	0.8 (11.6)	0.8 (11.6)	-	4	SCH284B004	-	-
2.7 (0.106)	4.9 (0.193)	0.65	0	0.8 (11.6)	0.8 (11.6)	-	9	SCH284A005	-	-
4.8 (0.189)	7.9 (0.311)	1.1	0	0.8 (11.6)	0.8 (11.6)	-	13	SCH284B006	-	-
6.4 (0.252)	9.5 (0.374)	1.4	0	0.8 (11.6)	0.8 (11.6)	-	13	SCH284B007	-	-
1.6 (0.063)	3.2 (0.126)	0.28	0	1.5 (21.8)	1.5 (21.8)	-	2.8	-	P284A020LCA00V1	P284A020LCA00V3
1.6 (0.063)	3.2 (0.126)	0.28	0	1.5 (21.8)	1.5 (21.8)	-	2.8	-	P284A021LCA00V1 2)	P284A021LCA00V3 2)
2) P284A021LCA00V1/P284A021LCA00V3 = The flange is rotatable with 90° (please see "Pic. 2" on following page)										
2/2 NO - Normally Open										
0.76 (0.030)	1.65 (0.065)	0.18	0	0.8 (11.6)	0.8 (11.6)	-	4	SCH284B009	-	-
1.02 (0.040)	2.16 (0.085)	0.22	0	0.8 (11.6)	0.8 (11.6)	-	4	SCH284B010	-	-
1.57 (0.062)	3.18 (0.125)	0.28	0	0.8 (11.6)	0.8 (11.6)	-	4	SCH284B011	-	-
1.98 (0.078)	3.18 (0.125)	0.25	0	0.8 (11.6)	0.8 (11.6)	-	4	SCH284B012	-	-
2.7 (0.106)	4.9 (0.193)	0.65	0	0.8 (11.6)	0.8 (11.6)	-	9	SCH284A013	-	-
4.8 (0.189)	7.9 (0.311)	1.1	0	0.8 (11.6)	0.8 (11.6)	-	13	SCH284B014	-	-
6.4 (0.252)	9.5 (0.374)	1.4	0	0.8 (11.6)	0.8 (11.6)	-	13	SCH284B015	-	-
1.6 (0.063)	3.2 (0.126)	0.28	0	1.5 (21.8)	1.5 (21.8)	-	2.8	-	P284A022LCA00V1	P284A022LCA00V3
1.6 (0.063)	3.2 (0.126)	0.28	0	1.5 (21.8)	1.5 (21.8)	-	2.8	-	P284A023LCA00V1 2)	P284A023LCA00V3 2)

2) P284A023LCA00V1/P284A023LCA00V3 = The flange is rotatable with 90° (please see "Pic. 2" on following pages)

ASCO™ MINIATURE SOLENOID VALVES

PINCH VALVES, COMPACT 2-WAY SOLENOID

How to Order Aluminium body

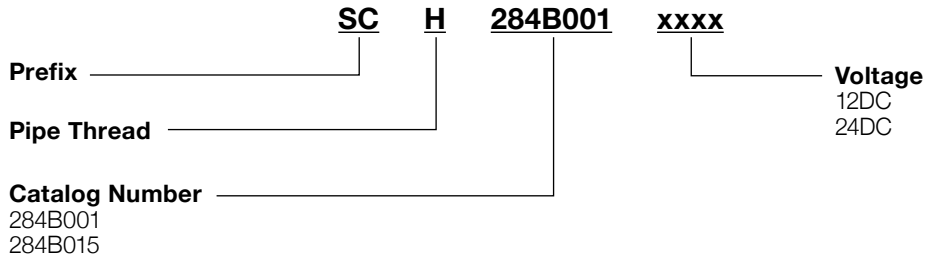

How to Order POM Body

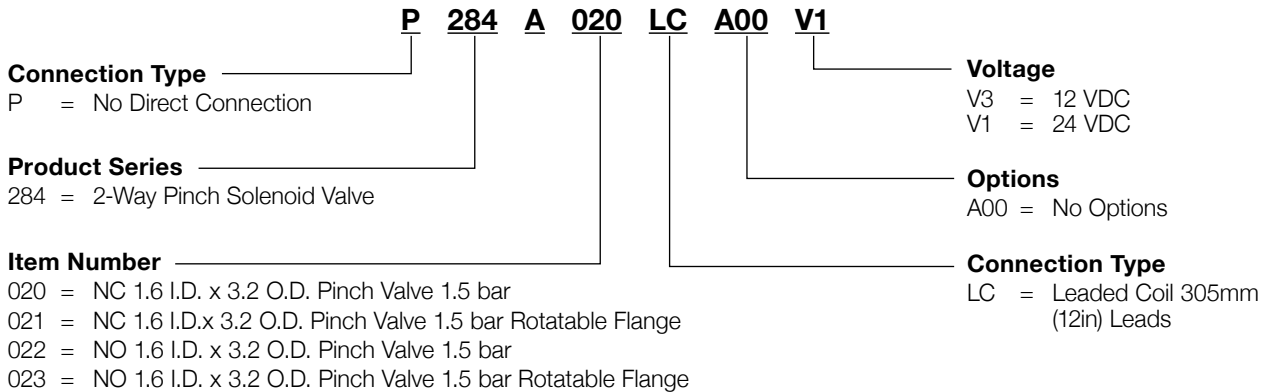

Options

- Flexible tubes having to use an external guiding device for optimum support (see dimensions):
 - With an outside diameter lower than 2.2mm (0.087in) (catalog numbers **SCH284B001** to **..B004**)
 - With an outside diameter lower than 3.5mm (0.138in) (catalog number **SCH284A005**)
 - With an outside diameter lower than 6mm (0.236in) (catalog numbers **SCH284B006** and **..007**)
- Contact us for information regarding the usage of different tubing other than those recommended
- Plug with visual indication and peak voltage suppression or with cable length of 2m (78.7in)

Installation

- The solenoid valves can be mounted in any position without affecting operation, however, for optimum performance it is recommended that they be fitted with the solenoid operator at the top
- Fixing plate built in between the body and the coil for assembly in a bank on a base plate
- Flexible tubes are not included with valve
- In case the tubing is not placed in its seat, the solenoid valve could operate incorrectly.

01085GB-2019-R01

Dimensions: mm (inches)

Type 01

Prefix "SC" solenoid
IEC 335/DIN 43650
IP65



**Type 01: SCH284B001/002/003/004/
009/010/011/012**

Type 02-03

Prefix "SC" solenoid
IEC 335/ISO 4400
IP65



Type 02: SCH284A005/A013
Type 03: SCH284B006/B007/B014/B015

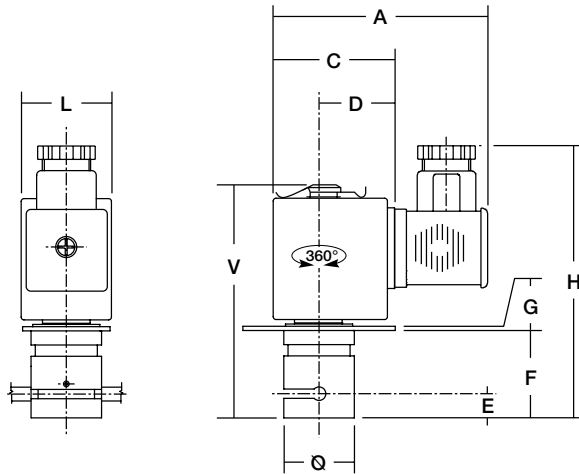

Tube Guiding Device

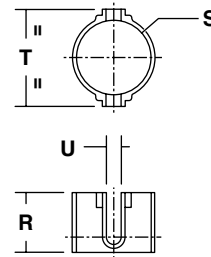

Arrangement for Mounting

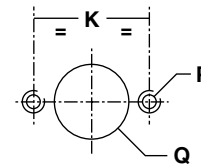

Bottom View

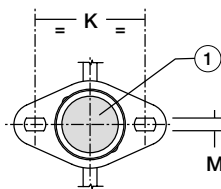

① Impulse Manual Operator

Example of Banked Assembly

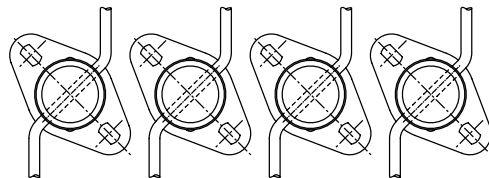

Type	Prefix Option	Catalog Number	Ø	A	C	D	E	F	G	H	K	L	M	P	Q	R	S	T	U	V	Weight ¹ kg	Tube Guiding Device	
																						Catalog Number	Weight ¹ kg
01	SC	SCH284B001/002/003/004/009/010/011/012	16 (0.63)	49.5 (1.95)	23.5 (0.93)	15 (0.60)	11 (0.43)	20 (0.79)	1 (0.04)	66 (2.60)	24 (0.95)	17 (0.67)	3.3 (0.13)	M3	16.5 (0.65)	10.7 (0.42)	16 (0.63)	24 (0.95)	2.2 (0.09)	51.2 (2.02)	0.06	C140094	0.005
02	SC	SCH284A005/A013	25 (0.98)	78 (3.07)	43 (1.69)	27 (1.06)	17.5 (0.69)	32 (1.26)	1.5 (0.06)	99 (3.90)	39 (1.54)	32 (1.26)	4.5 (0.18)	M4	25.5 (1.00)	14 (0.55)	25 (0.98)	33 (1.30)	3.2 (0.13)	82.5 (3.25)	0.28	C140095	0.009
03	SC	SCH284B006/B007/B014/B015	30 (1.18)	84 (3.31)	49 (1.93)	28 (1.10)	24.5 (0.96)	43.5 (1.71)	1.5 (0.06)	99 (3.90)	45.5 (1.80)	42 (1.65)	4.5 (0.18)	M4	30.5 (1.20)	24 (0.94)	30 (1.18)	39 (1.54)	6 (0.24)	99 (3.90)	0.47	C140096	0.015

¹ Including coil(s) and connectors

ASCO™ MINIATURE SOLENOID VALVES

PINCH VALVES, COMPACT 2-WAY SOLENOID

Dimensions: mm (inches)

2/2 Normally Closed

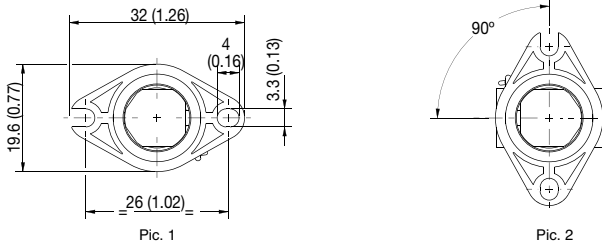

2/2 Normally Open

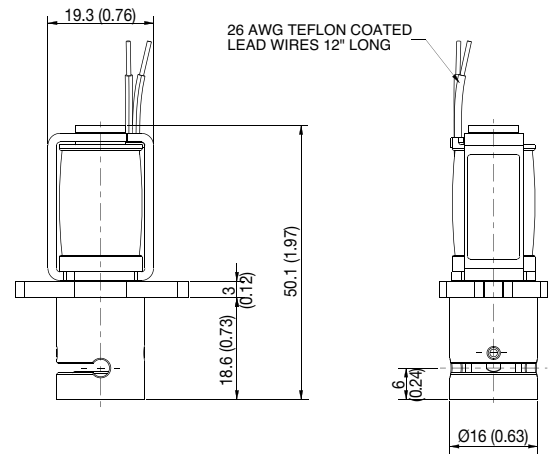
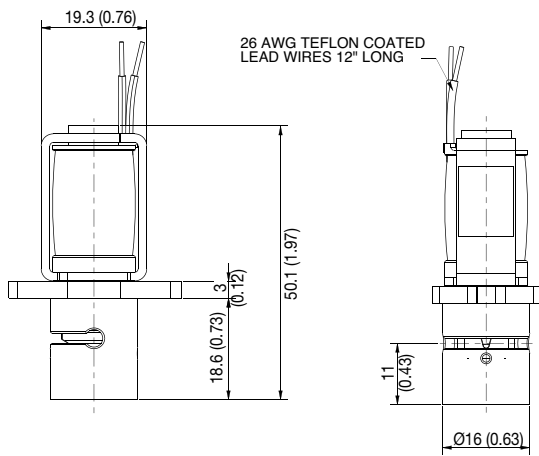
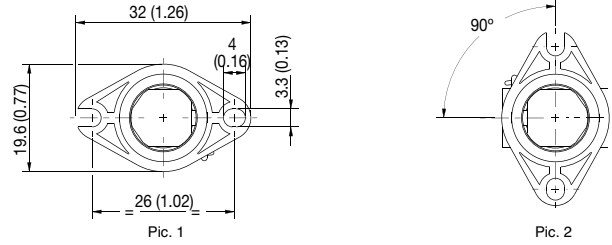

Tube Guiding Device

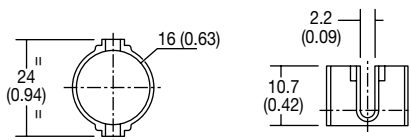

Arrangement for Wall-fitting

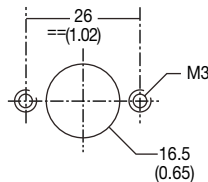

Catalog Number	Weight
	kg
P284A020LCA00V1/V3	0.04
P284A021LCA00V1/V3	
P284A022LCA00V1/V3	
P284A023LCA00V1/V3	

Tube Guiding Device	
Catalog Number	Weight
	kg
25978-01	0.005

01085GB-2019-R01

ASCO™ MINIATURE SOLENOID VALVES

PINCH VALVES, COMPACT 3-WAY SOLENOID

- The 384 Series is a 3-Way universal solenoid-operated pinch valve designed for use with highly aggressive or high-purity liquids in analytical and medical instrumentation, and industrial applications
- Hermetic separation of control mechanism and the fluid within the tubing prevents particulate contamination caused by friction of moving parts, assuring maximum purity of liquids
- Available in a large range of body sizes to accommodate a wide variety of tubing sizes
- Removable and rotatable electrical coils allow for easy installation and worry-free maintenance
- Bi-directional flow for exceptional versatility
- Meets all relevant CE directives, and is RoHS compliant
- Typical applications include:
 - Hemodialysis
 - Urinary Collection Systems,
 - Intravenous (IV) Systems
 - Drug Dispensing

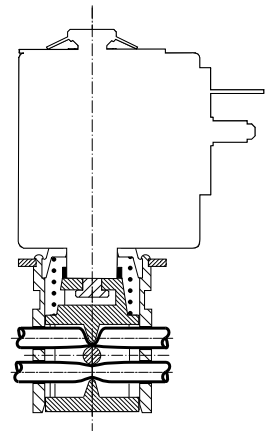
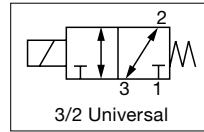

Fluids*	Temperature Range
Air, Inert Gases, Water, Oil or Liquids	0 °C to 50 °C (32 °F to 122 °F)

* Ensure that the compatibility of the materials in contact with the fluids is verified

General Valve Information*		
Body	Aluminum, anodized	POM (Graphite-reinforced polyacetal)
Pinch Mechanism	POM (Graphite-reinforced polyacetal)	
Others	Stainless Steel	
Guide Tube	Nickel-plated Brass	
Coil frame	Galvanized steel	
Recommended Tubing	VMQ (silicone) (max. hardness: 50 Shore A) (Tubing not supplied with valve)	VMQ (silicone) (max. Hardness: 50 Shore A) 30cm (12in) tubing supplied with valve

Electrical Characteristics		
	Aluminium body	POM body
Coil Insulation Class	F	F
Connector	Spade plug; cable Ø4-6mm (0.16-0.24in), Ø6-10mm (0.24-0.40in)	
Connector Specification	4 W/8 W/6 W (DMX); DIN 43650, 9.4 mm, industry standard B; 6 W/13 W (AMX/FNX); ISO 4400/EN 175301-803, form A	305mm (12in) Lead Wires
Electrical Safety	IEC 335	IEC 335
Electrical Enclosure Protection	Coil type 01 = IP65 / Coil type 02-03 = IP65	IP30 (EN 60529)
Standard Voltages ¹	12 VDC, 24 VDC	12 VDC, 24 VDC
Power Consumption	4W, 6W, 8W, 9W, 13W	3.5W
Response Time	< 20ms	< 10ms

¹ Other voltages on request

Prefix Option	Power Ratings				Ambient Temperature Ranges °C (°F)	Replacement Coil		Type ²
	Inrush VA	Holding VA	Hot/Cold W			12 VDC	24 VDC	
			W	W				
SC	-	-	4	-10 to 60 (14 to 140)	43005268	43005269	01 (DNX-4)	
			8		500701-001	500701-002		
			6		500701-003	500701-004		
			9		43005143	43005144		02 (AMX)
			13		43005316	43005317	03 (FNX)	

² Refer to the dimensional drawings on the following page

USE IN INTERMITTENT SERVICE
Minimum waiting time between each application of power

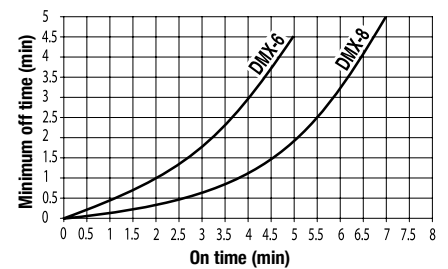

01086GB-2019-R01

Specifications										
Tube I.D.	Tube O.D.	Pinch Force	Operating Pressure bar (psi)			Power Rating		Catalog Number		
			min.	max.						
mm (inches)	mm (inches)	daN		inert gases	liquids	W	Aluminium body	POM body		
								24 VDC	12 VDC	
0.76 (0.030)	1.65 (0.065)	0.12	0	0.8 (11.6)	0.8 (11.6)	- 4	SCH384B004	-	-	
1.02 (0.040)	2.16 (0.085)	0.18	0	0.8 (11.6)	0.8 (11.6)	- 4	SCH384B001	-	-	
1.57 (0.062)	3.18 (0.125)	0.22	0	0.8 (11.6)	0.8 (11.6)	- 8	SCH384B0023	-	-	
1.98 (0.078)	3.18 (0.125)	0.18	0	0.8 (11.6)	0.8 (11.6)	- 6	SCH384B0033	-	-	
3.4 (0.132)	4.7 (0.183)	0.4	0	0.8 (11.6)	0.8 (11.6)	- 9	SCH384A005	-	-	
4.8 (0.187)	7.9 (0.313)	0.85	0	0.8 (11.6)	0.8 (11.6)	- 13	SCH384B006	-	-	
6.4 (0.250)	9.5 (0.375)	1.1	0	0.8 (11.6)	0.8 (11.6)	- 13	SCH384B007	-	-	
1.6 (0.063)	3.2 (0.126)	0.22	0	1.5 (21.8)	1.5 (21.8)	- 3.5	-	P384A024LCA00V1	P384A024LCA00V3	
1.6 (0.063)	3.2 (0.126)	0.22	0	1.5 (21.8)	1.5 (21.8)	- 3.5	-	P384A025LCA00V14	P384A025LCA00V34	

³ Observe the minimum of time stated, see graph above ⁴ The flange is rotatable with 90° (please see "Pic. 2" on following page)

How to Order

Aluminum body

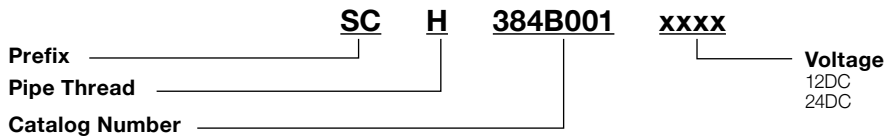

How to Order

POM Body

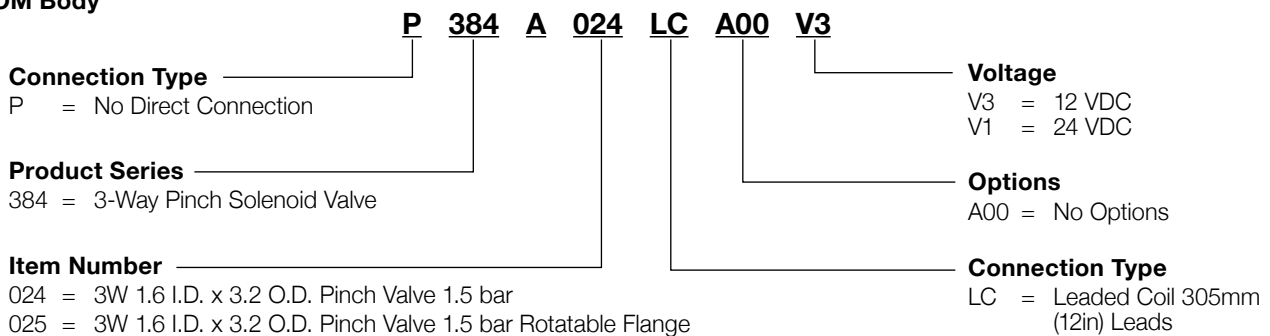

ASCO™ MINIATURE SOLENOID VALVES

PINCH VALVES, COMPACT 3-WAY SOLENOID

Dimensions (Aluminium body): mm (inches)



Type 01 Prefix "SC" solenoid
IEC 335/DIN 43650
IP65

Type 01: SCH384B001/0002/003/004

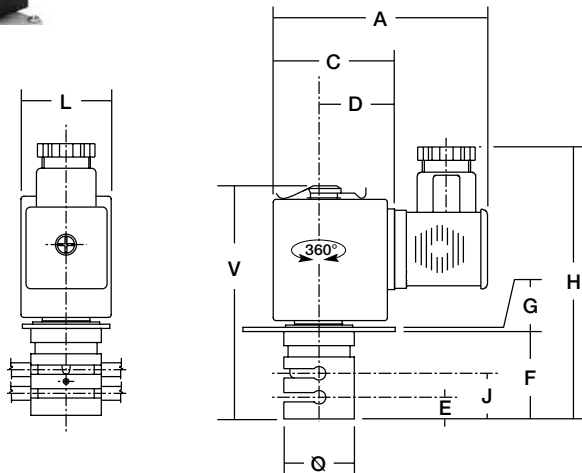

① Impulse Manual Operator

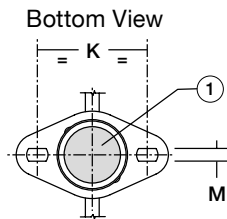

Type 02-03 Prefix "SC" solenoid
IEC 335/ISO 4400
IP65

Type 02: SCH384A005
Type 03: SCH384B006/B007

Tube Guiding Device Arrangement for Wall-Fitting

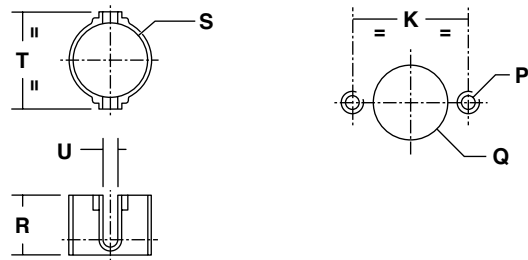

Example of Banked Assembly

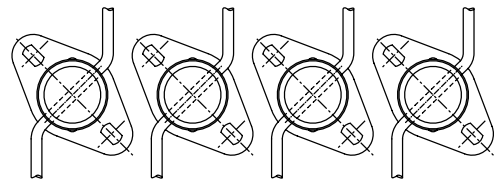

Type	Prefix Option	Catalog Number	Ø	A	C	D	E	F	G	H	K	L	M	P	Q	R	S	T	U	V	Weight ¹		
																					kg	kg	
01	SC	SCH384B001/002/003/004	16 (0.63)	49.5 (1.95)	23.5 (0.92)	15 (0.59)	11 (0.24)	20 (0.79)	1 (0.04)	66 (2.60)	24 (0.43)	17 (0.67)	3.3 (0.13)	M3	16.5 (0.65)	10.7 (0.42)	16 (0.63)	24 (0.94)	2.2 (0.09)	51.2 (2.02)	0.06	C140094	0.005
02	SC	SCH384A005	25 (0.98)	78 (3.07)	43 (1.69)	27 (1.06)	17.5 (0.41)	32 (1.26)	1.5 (0.06)	99 (3.90)	39 (1.54)	32 (1.26)	3.3 (0.18)	M4	25.5 (1.00)	14 (0.55)	25 (0.98)	33 (1.30)	3.2 (0.12)	82.5 (3.25)	0.30	C140095	0.009
03	SC	SCH384B006/B007	30 (1.18)	84 (3.31)	49 (1.93)	28 (1.10)	24.5 (0.96)	43.5 (1.71)	1.5 (0.06)	99 (3.90)	45.5 (1.79)	42 (1.65)	4.5 (0.18)	M4	30.5 (1.20)	24 (0.94)	30 (1.18)	39 (1.54)	6 (0.24)	99 (3.90)	0.45	C140096	0.015

Tube Guiding Device	
Catalog Number	Weight ¹ kg
C140094	0.005
C140095	0.009
C140096	0.015

¹ Including coil(s) and connectors

Options (Aluminium body)

- Flexible tubes having to use an external guiding device for optimum support (see dimensions):
 - With an outside diameter lower than 2.2mm (0.087in) (catalog numbers **SCH384B001** to **.B004**)
 - With an outside diameter lower than 3.5mm (0.138in) (catalog number **SCH384A005**)
 - With an outside diameter lower than 6mm (0.240in) (catalog numbers **SCH384B006** and **..007**)
 - Contact us for information regarding the usage of different tubing other than those recommended
- Plug with visual indication and peak voltage suppression or with cable length of 2m (78.7in)

Installation (Aluminium body)

- The solenoid valves can be mounted in any position without affecting operation, however, for optimum performance it is recommended that they be fitted with the solenoid operator at the top
- Fixing plate built in between the body and the coil for assembly in a bank on a base plate
- Flexible tubes are not included in our supply
- In case the tubing is not placed in its seat, the solenoid valve could operate incorrectly.

01086GB-2019-R01

Dimensions (POM body): mm (inches)

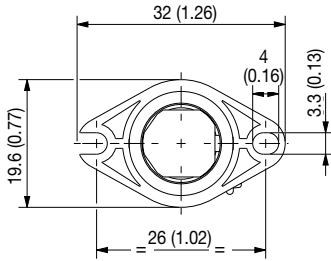

Pic. 1

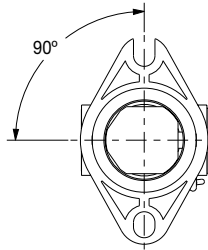

Pic. 2

Tube Guiding Device

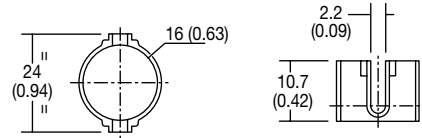

Arrangement for Wall-fitting

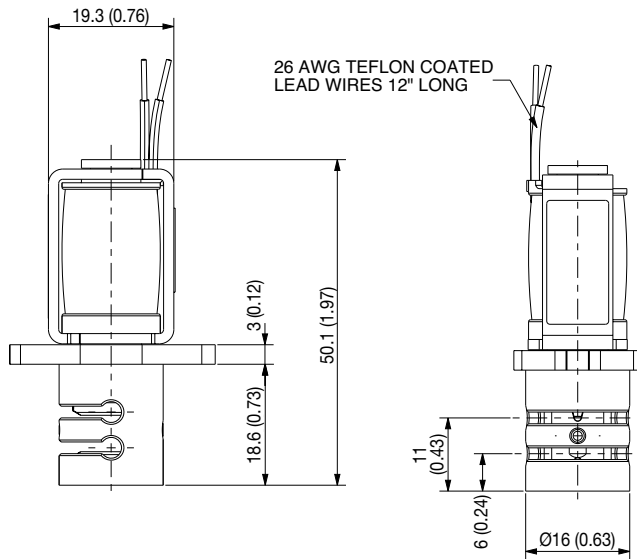
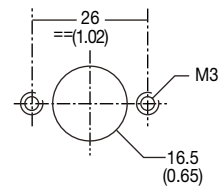

Catalog Number	Weight ¹	Tube Guiding Device	
	kg	Catalog Number	Weight ¹
P384A024LCA00V1/V3	0.04		
P384A025LCA00V1/V3		25978-01	0.005

¹ Including coil(s) and connectors

Options (POM body)

- Flexible tubes having to use an external guiding device for optimum support (see dimensions);
- With an outside diameter lower than 2.2mm (0.087in)
- Contact us for information regarding the usage of different tubing other than those recommended

Installation (POM body)

- The solenoid valves can be mounted in any position without affecting operation, however, for optimum performance it is recommended that they be fitted with the solenoid operator at the top
- Fixing plate built in between the body and the coil for assembly in a bank on a base plate
- In case the tubing is not placed in its seat, the solenoid valve could operate incorrectly.

ASCO™ MINIATURE SOLENOID VALVES

ROCKER MECHANISM, FLUID ISOLATION VALVES

- Rocker isolation valves are designed for use with neutral or highly aggressive liquids in analytical instrumentation
- Special rocker mechanism, combined with a separating diaphragm, prevents heat transfer to the fluid and eliminates the sticking effect of the valve seat
- Hermetic separation of control mechanism prevents particulate contamination caused by friction of moving parts, assuring maximum purity of liquid samples
- Excellent self-draining capability and easy-to-flush low-volume internal cavity make these valves ideal in application where cross-contamination must be minimized
- Removable and rotatable electrical coils allow for easy installation and worry-free maintenance
- Meets all relevant CE directives
- Typical applications include:
 - In-vitro Diagnostics
 - Hematology
 - DNA Sequencing
 - Surgical Fluid Management

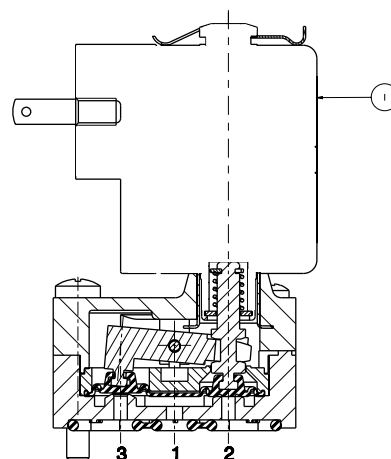
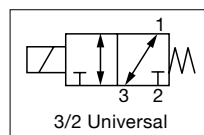

Fluids*	Temperature Range	Seal Materials*
liquids or gases	10°C to +80°C (14°F to 176°F)	FFKM (perfluoroelastomer) or EPDM (ethylene-propylene)

* Ensure that the compatibility of the materials in contact with the fluids is verified

General Valve Information		
	PEEK Body	PA Body
Body	PEEK	PA (polyamide 12)
Differential pressure	See «Specifications» [1 bar =100 kPa] 0.7 bar abs. (vacuum on polyamide body only)	
Maximum viscosity	37 cSt (mm ² /s)	
Response time	20 ms	
Internal volume	< 67 µl	

Electrical Characteristics	
Coil insulation class	F
Coil	Detachable and rotatable. Two spade terminals 2.8 x 0.5 mm (DIN 46340) (or detachable size 15 connector)
Electrical enclosure protection	Moulded IP 65 spade terminals Moulded IP 66 Solenoid lead wires (EN 60529)
Standard voltages *	12 VDC, 24 VDC

* Other voltages on request.

Prefix option	Power ratings				Ambient temperature range °C (°F)	Replacement coil		Type (1)
	Inrush		Holding			12 VDC	24 VDC	
	VA	VA	W	W				
SC	-	-	-	4	-10 to 60 (14 to 140)	43005268	43005269	1
L	-	-	-	4	-10 to 60 (14 to 140)	43005408	43005430	2

(1) Refer to the dimensional drawings on the following page.

01003GB-2019-R01

Specifications													
Pipe Size	Orifice Size	Flow Coefficient			Operating Pressure bar (psi)			Power Rating (W)		Catalog Number		Seal Materials	
					min.	max. (PS)						FKM	EPDM
		(mm)	Kv (m ³ /h)	Cv		(l/min)	Gases (*)	Liquids (*)	PEEK Body	PA Body			
Pad mount	1.5	0.03	0.034	0.5	0	2.4 (34.8)	2.4 (34.8)	-	4	SCS385A001		V	E
1/4" - 28 UNF thread										SCE385A001			
Barbed fitting										SCH385A001			
Pad mount	1.5	0.03	0.034	0.5	0	2 (29.0)	2 (29.0)	-	4		SCS385A002E	-	-
1/4" - 28 UNF thread											SCE385A002E		
Barbed fitting											SCH385A002E		

How To Order

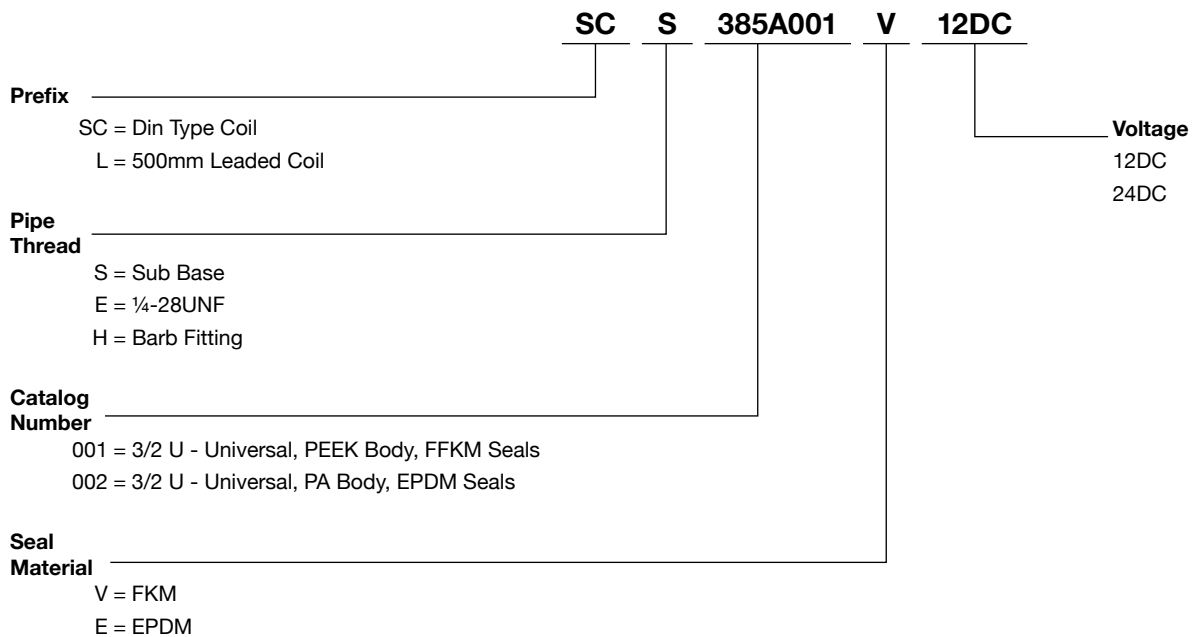

Options

- Connector size 15, catalogue number 88143581

Installation

- The solenoid valves can be mounted in any position without affecting operation.
- Can be used for the following functions, depending on how the ports are connected:
- Installation/maintenance instructions are included with each valve.

ASCO™ MINIATURE SOLENOID VALVES

ROCKER MECHANISM, FLUID ISOLATION VALVES

Dimensions: mm (inches)



Type 01
Solenoid with spade terminals (SC)
EN 60529
IP 65

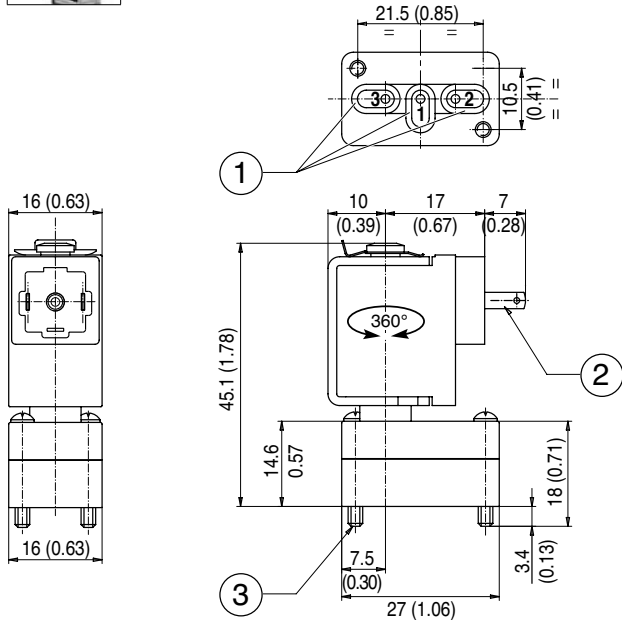

- ① 1 mounting pad seal.
- ② Coil with 2 Faston-type terminals 2.8 x 0.5 (DIN 46340).
- ③ Mounting : 2 screws M2.5 x 18.

Type	Prefix option	Weight (1) kg
01	SC	0.04

(1) Including coil, without connector.



Type 02
Leaded Coil (L)
24 AWG, lead wires: 500 mm (19.7 in) long
IP 66

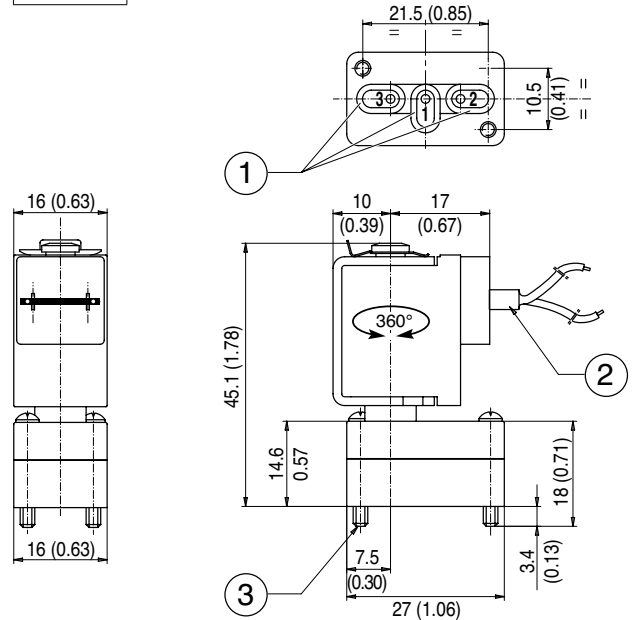

- ① 1 mounting pad seal.
- ② Coil with 24 AWG, lead wires: 500mm (19.7in) long
- ③ Mounting : 2 screws M2.5 x 18.

Type	Prefix option	Weight (1) kg
02	L	0.04

(1) Including coil, without connector.

01003GB-2019-R01

Dimensions: mm (inches)

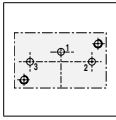

Pad Mount

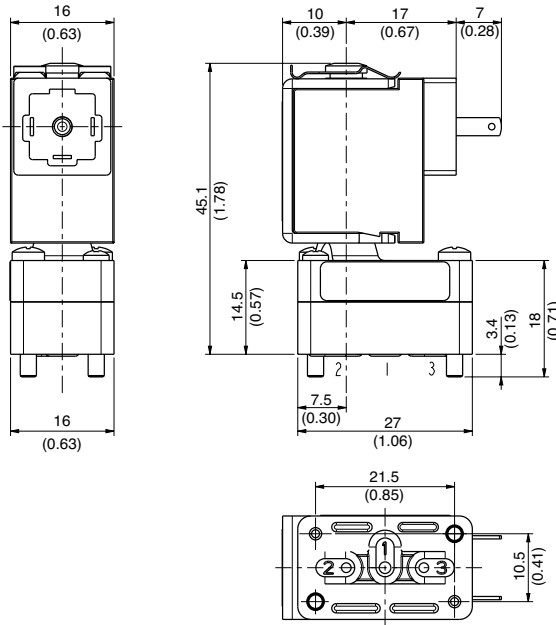

1/4" - 28 UNF thread

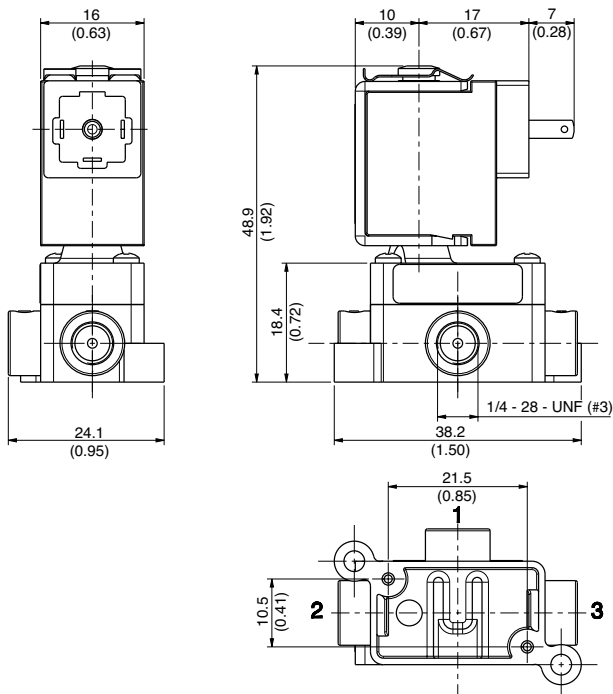

Barbed Fitting

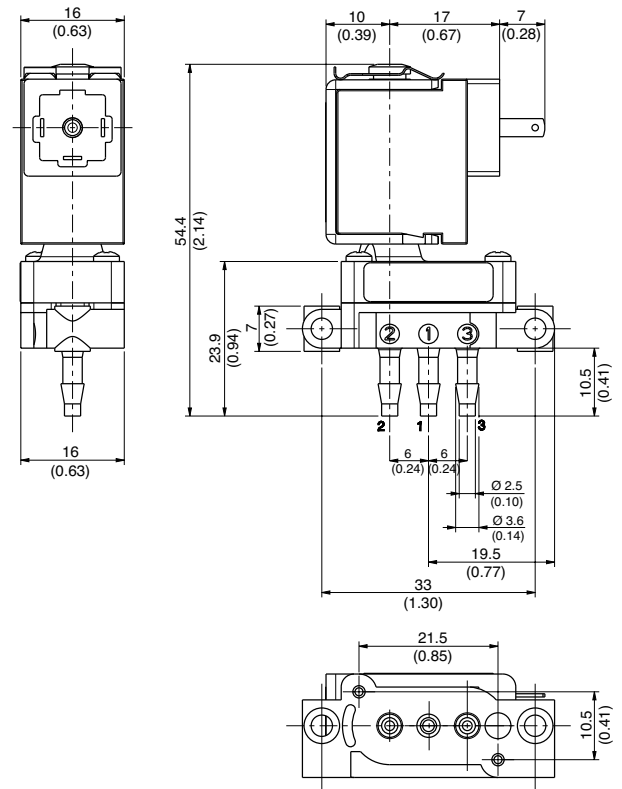

ASCO™ MINIATURE SOLENOID VALVES

GENERAL SERVICE VALVES, FLAT SPRING SOLENOID

- The 065 Series 2-Way and 3-Way manifold mount valves are designed for analytical and medical applications where high gas flow is required
- Flat spring technology ensures no contamination of gases (no friction)
- The valves have a service life of more than 1 billion cycles when used with inert gases
- Very short response times allow these valves to be used in applications that require precise media control
- Small form factor saves valuable space in portable devices
- Available in a variety of versions for a wide range of applications: threaded connections or pad-mount for installation on multiple manifolds
- Meets all relevant CE directives, and is RoHS compliant
- Typical applications include:
 - Respiratory Therapy
 - Patient Monitoring
 - Compression Therapy (DVT)
 - Industrial Air Monitoring

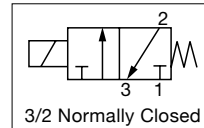
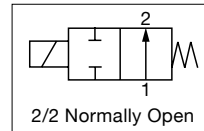
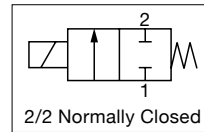

Fluids*	Temperature Range	Seal Materials*
Air, Inert Gases	0 °C to 60 °C (0 °F to 140 °F)	FKM (fluoroelastomer), EPDM, NBR ¹

¹ FFKM seals for corrosive fluids available on request
 * Ensure that the compatibility of the materials in contact with the fluids is verified.

General Valve Information	
Body	Stainless steel, AISI 303 (1.4305)
Others	Stainless steel, FKM
Response Time	< 10ms
Vacuum Rating	-1 bar (-14.5 psi)
Maximum Viscosity	20 cSt (mm ² /s)

Electrical Characteristics	
Coil Insulation Class	F
Electrical Safety	IEC 335
Standard Voltages	6 VDC, 12 VDC, 24 VDC
Power Consumption	2 W at 20 °C

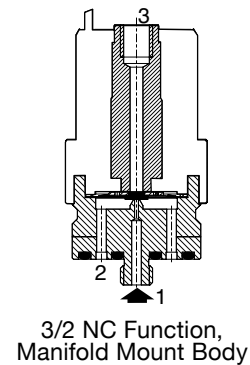
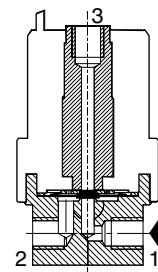
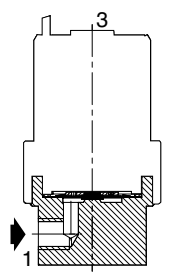
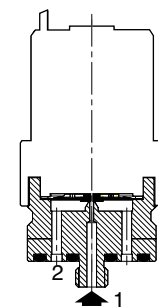
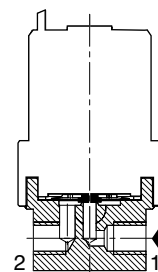

Protection	Power Rating				Ambient Temperature Range	Electrical Connection	Type ¹
	Inrush	Holding		Hot/Cold			
VA	VA	VA	W	W	°C (°F)		
IP40 (EN 60529)	-	-	-	2.1/2.1	0 to 60 (0 to 140)	Lead wires (ETFE), length 0.35m (13.8in)	01

¹ Refer to the dimensional drawings on the following page

Specifications								
Connection	Orifice Size	Flow Coefficient		Operating Pressure bar (psi)		Power Rating	Catalog Number	
		mm (inches)	Kv (m ³ /h)	Cv	min.		max.	W
2/2 NC - Normally Closed								
M5 1	0.6 (0.024)	0.013	0.015	0	7 (101)	2.1	LE065A001V	LS065A001V
	1.0 (0.040)	0.025	0.029	0	5 (72.5)	2.1	LE065A002V	LS065A002V
	1.4 (0.055)	0.032	0.037	0	3 (43.5)	2.1	LE065A003V	LS065A003V
	2.0 (0.080)	0.057	0.066	0	1.5 (21.8)	2.1	LE065A004V	LS065A004V
2/2 NO - Normally Open								
M5	0.6 (0.024)	0.013	0.015	0	7 (101)	2.1	LE065A005V	-
	1.0 (0.040)	0.025	0.029	0	5 (72.5)	2.1	LE065A006V	-
	1.4 (0.055)	0.032	0.037	0	3 (43.5)	2.1	LE065A007V	-
	2.0 (0.080)	0.057	0.066	0	1.5 (21.8)	2.1	LE065A008V	-
3/2 NC - Normally Closed								
M5 1	0.6 (0.024)	0.013	0.015	0	7 (101)	2.1	LE065A009V	LS065A009V
	1.0 (0.040)	0.025	0.029	0	5 (72.5)	2.1	LE065A010V	LS065A010V
	1.4 (0.055)	0.032	0.037	0	3 (43.5)	2.1	LE065A011V	LS065A011V
	2.0 (0.080)	0.057	0.066	0	1.5 (21.8)	2.1	LE065A012V	LS065A012V

1 External thread with pad-mount body

How to Order

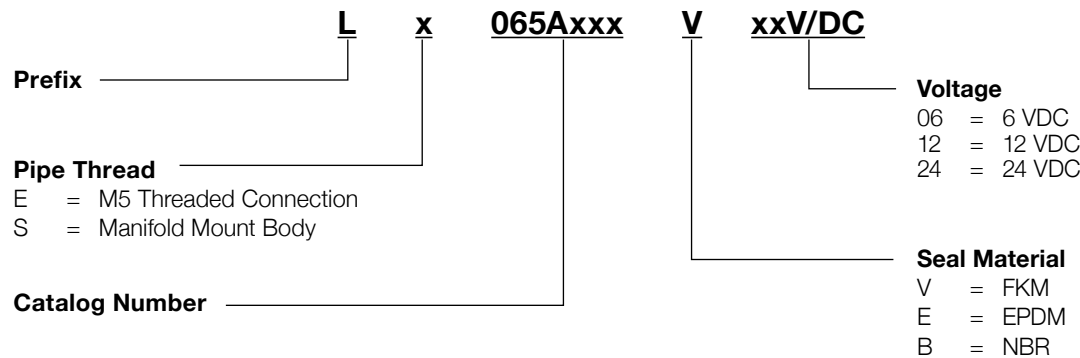

Options

- Cleaned for oxygen service
- Other pipe connections are available
- 0.7 W rated coil available on request

Installation

- The solenoid valves can be mounted in any position without affecting operation
- Threaded solenoid valves have 2 mounting holes in body

ASCO™ MINIATURE SOLENOID VALVES

GENERAL SERVICE VALVES, FLAT SPRING SOLENOID

Dimensions: mm (inches)

2-Way Flat Spring Solenoid

Type 01 Prefix "L" solenoid
Leaded Coil
IP40



LE065A001V/002V/003V/004V

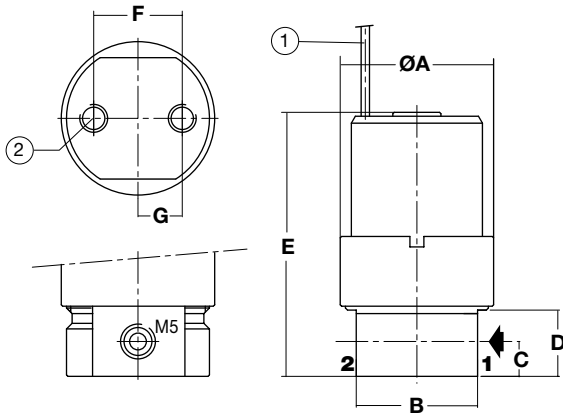

LS065A001V/002V/003V/004V

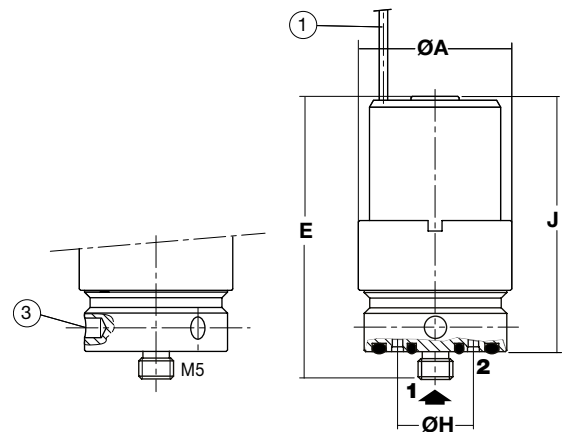

LE065A005V/006V/007V/008V

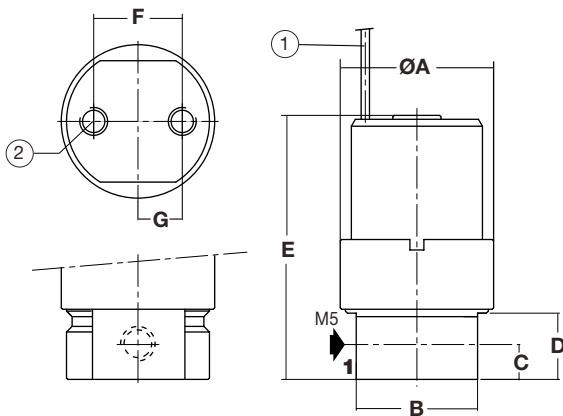

Mounting pad

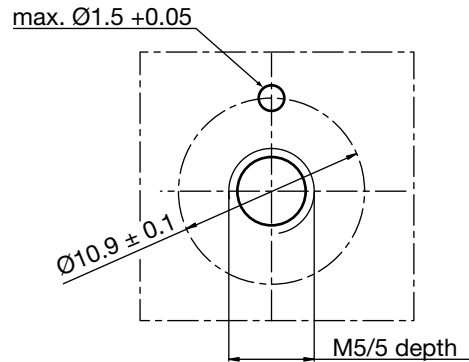

- ① 2 electrical supply wires, length: 0.35m (13.8in)
- ② 2 mounting holes ØM4, depth: 6mm (0.24in)
- ③ Mounting with hook spanner wrench DIN 1810B

Type	Prefix Option	Catalog Number	A	B	C	D	E	F	G	H	J
01	L	LE065A001V/002V/003V/004V	22 (0.87)	17.4 (0.69)	5 (0.20)	9.5 (0.37)	38 (1.50)	12.7 (0.50)	6.35 (0.25)	-	-
		LS065A001V/002V/003V/004V	22 (0.87)	-	-	-	41 (1.61)	-	-	10.9 (0.43)	37 (1.46)
		LE065A005V/006V/007V/008V	22 (0.87)	17.4 (0.69)	5 (0.20)	9.5 (0.37)	38 (1.50)	12.7 (0.50)	6.35 (0.25)	-	-

1 Including leads, length: 0.35m (13.8in)

01089GB-2019-R01

Dimensions: mm (inches)

3-Way Flat Spring Solenoid

Type 01 Prefix "L" solenoid
Leaded Coil
IP40



LE065A009V/010V/011V/012V

LS065A009V/010V/011V/012V

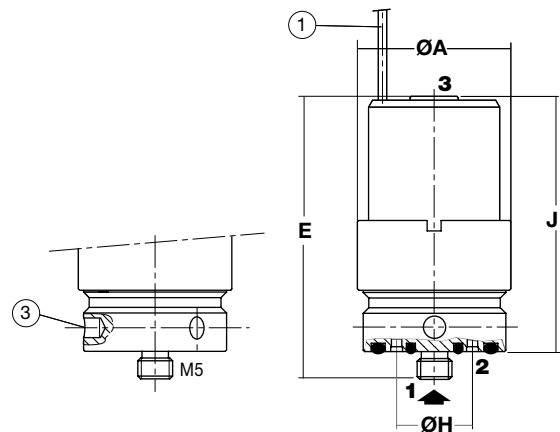
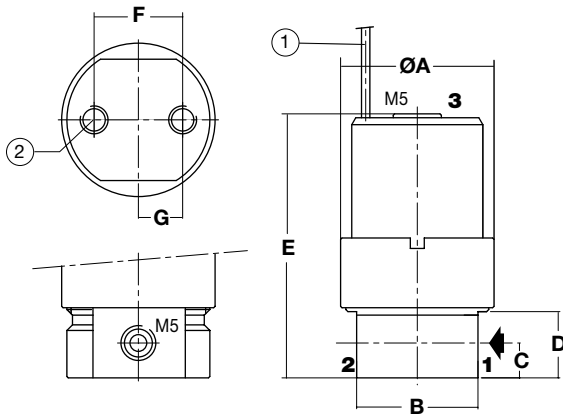

Mounting pad

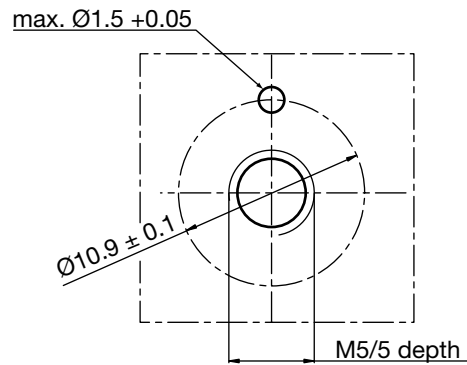

- ① 2 electrical supply wires, length: 0.35m (13.8in)
- ② 2 mounting holes ØM4, depth: 6mm (0.24in)
- ③ Mounting with hook spanner wrench DIN 1810B

Type	Prefix Option	Catalog Number	A	B	C	D	E	F	G	H	J
01	L	LE065A009V/010V/011V/012V	22 (0.87)	17.4 (0.69)	5 (0.20)	9.5 (0.37)	38 (1.50)	12.7 (0.50)	6.35 (0.25)	-	-
		LS065A009V/010V/011V/012V	22 (0.87)	-	-	-	41 (1.61)	-	-	10.9 (0.43)	37 (1.46)

1 Including leads, length: 0.35m (13.8in)

01089GB-2019-R01

ASCO™ MINIATURE SOLENOID VALVES

GENERAL SERVICE VALVES, MINIATURE SOLENOID

- Series 076 solenoid valves are designed for use with air and inert gases and can also be used to pilot other valves or cylinders.
- Compact architecture and low power consumption of only 0.9 W make them ideal for portable medical devices.
- Option for side-by-side mounting on complex manifold solutions is ideal for control of multiple flow paths in portable or small envelope applications.
- Meets all relevant CE directives, and is RoHS compliant.
- Typical applications include:
 - Respiratory Therapy
 - Patient Simulators
 - Pilot Valves
 - Wide Range of Other General Service Needs

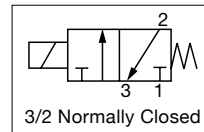

Fluids	Temperature Range	Seal Materials
Air or Inert Gas, non-lubricated	-5 °C to 50 °C (23 °F to 122 °F)	FKM

NOTE: Additional constructions and options are available including alternate elastomers and orifice sizes. Minimum quantities apply.

General Valve Information	
Body	PA / PBT
Others	Acetal, Brass, Nickel, Stainless Steel
Response Time	< 10ms

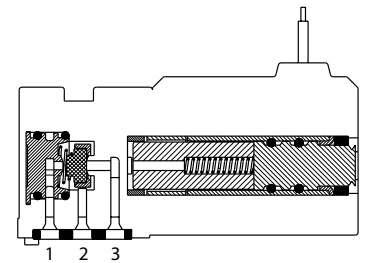

3/2 NC Pad Mount Body

Electrical Characteristics	
Standard Voltages*	5 VDC, 12 VDC, 24 VDC
Power Consumption	0.9 W

* Other voltages on request

NOTE: The solenoid valves are designed for continuous operation within the maximum ambient temperature limits.

Insulation Class	Coil Insulation	Protection	Ambient Temperature Range	Electrical Connection
	°C (°F)		°C (°F)	
F	155 (311)	IP40	-5 to 50 (23 to 122)	24 AWG Lead wires, 0.3m (12.0in) long, PTFE coated

Specifications										
Orifice Size				Flow Coefficient		Operating Pressure bar (psi)		Power Rating	Voltage	Catalog Number
mm (inches)						min.	max.			
1	2	2	3	Kv (m ³ /h)	Cv	gases, liquids		W		
3/2 NC - Normally Closed										
0.7 (0.028)	0.8 (0.032)	0.011	0.009	-0.9 (-13)	6.9 (100)	0.9	24 VDC	R076A101L0V00F1		
							12 VDC	R076A101L0V00F3		
							5 VDC	R076A101L0V00D1		

01097GB-2019-R02

How to Order

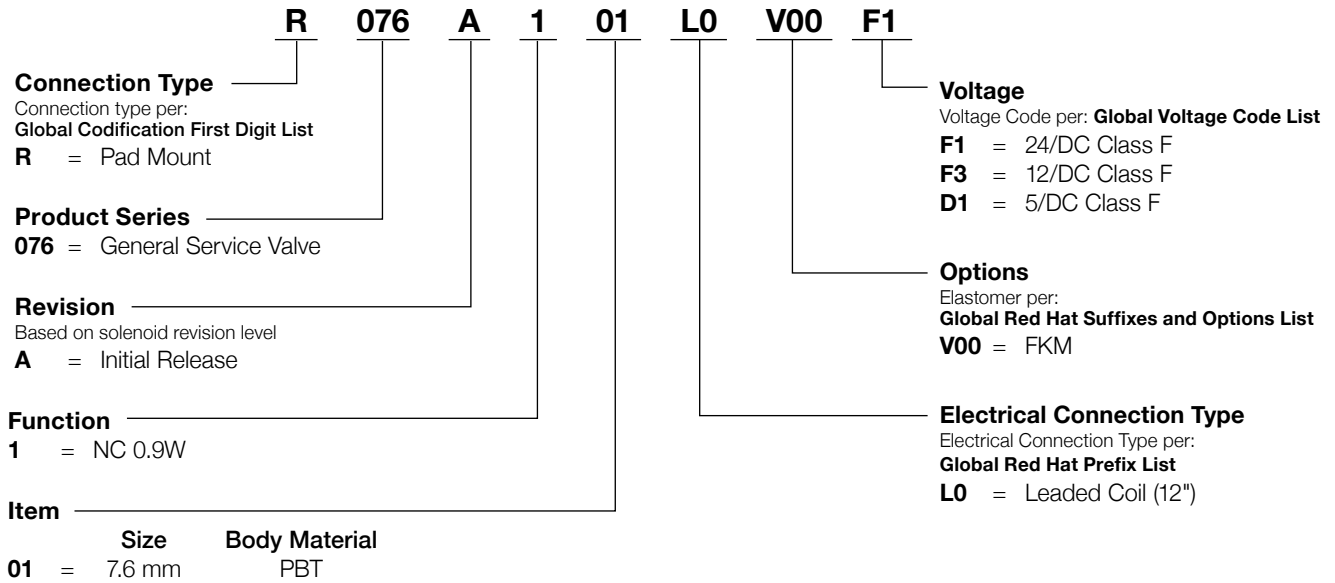

ASCO™ MINIATURE SOLENOID VALVES

GENERAL SERVICE VALVES, MINIATURE SOLENOID

Dimensions: mm (inches)

3-Way Pad Mount Solenoid Valve

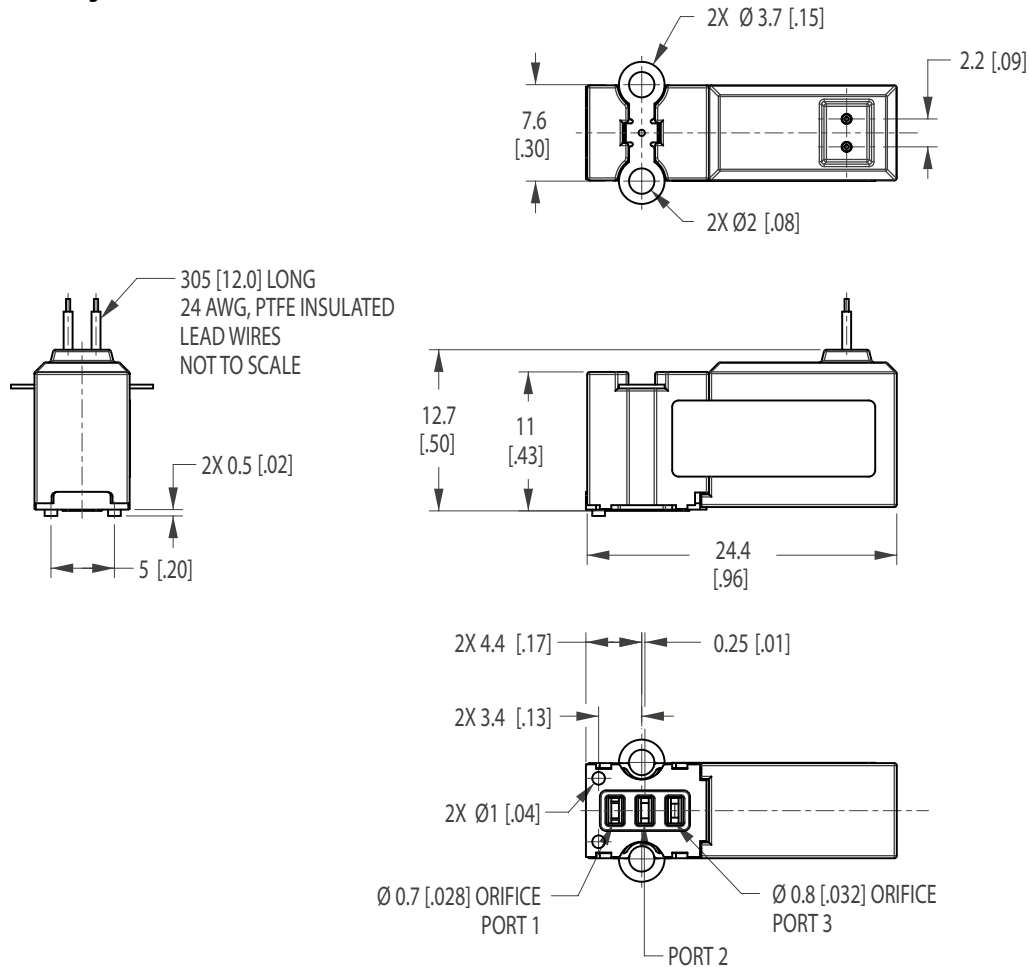

Manifold Interface

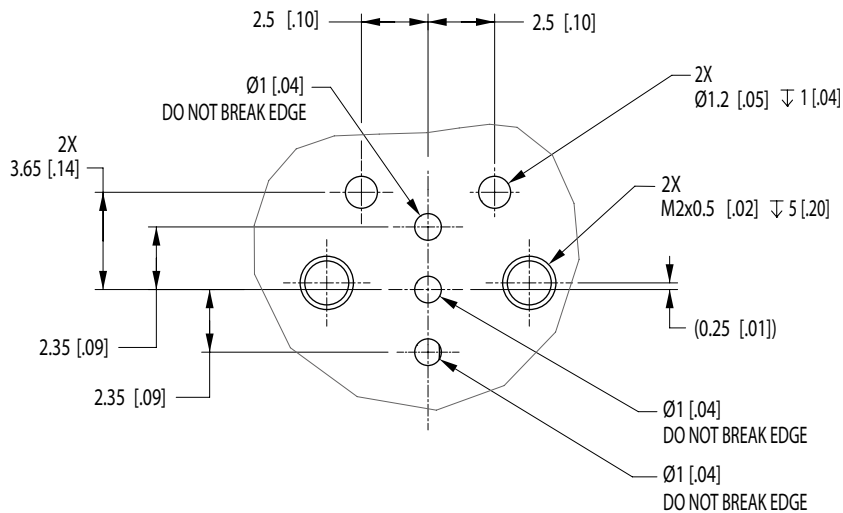

01097GB-2019-R02

ASCO™ MINIATURE SOLENOID VALVES

GENERAL SERVICE VALVES

- Series 090 solenoid valves are designed for use with air and inert gases
- Flow to size ratio ideal for portable oxygen therapy applications
- Compact light-weight architecture and low power consumption make them ideal for portable medical devices
- Exceptional service lifetime over 50 million cycles that increases OEM instrument reliability
- Meets all relevant CE directives, and is RoHS compliant
- Typical applications include:
 - Oxygen Delivery
 - Compression Therapy
 - Gas Analyzers

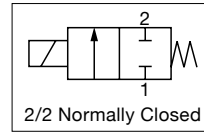

Fluids*	Temperature Range	Seal Materials*
Air or Inert Gas ¹	0 °C to 60 °C (32 °F to 140 °F)	FKM

¹ filtered at 10µm

* Ensure that the compatibility of the materials in contact with the fluids is verified.

NOTE: Additional constructions and options are available including alternate elastomers and orifice sizes. Minimum quantities apply.

General Valve Information	
Body	PBT
Others	Stainless Steel
Response Time	< 15ms
Vacuum Rating	-0.9 bar (13 psi)

Electrical Characteristics	
Duty Cycle	Intermittent, must use spike and hold noted below
Spike and Hold	Spike at nominal voltage for 500 – 5000 ms max. Hold at 50% of nominal voltage.
Connector	Lead wires
Connector Specification	28 AWG PVC insulated
Standard Voltages*	12 VDC, 24 VDC
Power Rating	4.3 W Inrush, 1.0 W Hold

* Other voltages on request

Insulation Class	Coil Insulation	Ambient Temperature Range	Electrical Connection
	°C (°F)	°C (°F)	
F	155 (311)	0 to 60 (32 to 140)	28 AWG PVC insulated

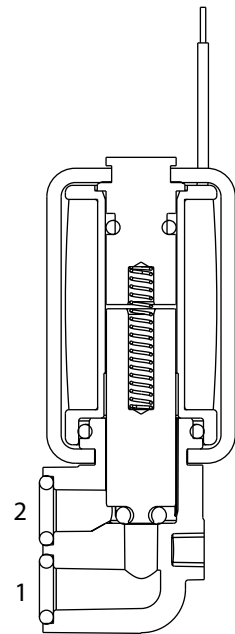

2/2 NC
Pad Mount

Specifications								
Connection	Orifice Size	Flow Coefficient		Operating Pressure bar (psi)		Power Rating (W)		Catalog Number
		Kv (m ³ /h)	Cv	min.	max.	Inrush	Hold	
2/2 NC - Normally Closed								
Pad Mount, PBT (F)	2.4 (0.093)	0.183	0.072	-0.9 (-13)	1.4 (20)	4.3	1.0	R090x220LAV00Fx

01096GB-2019-R01

How to Order

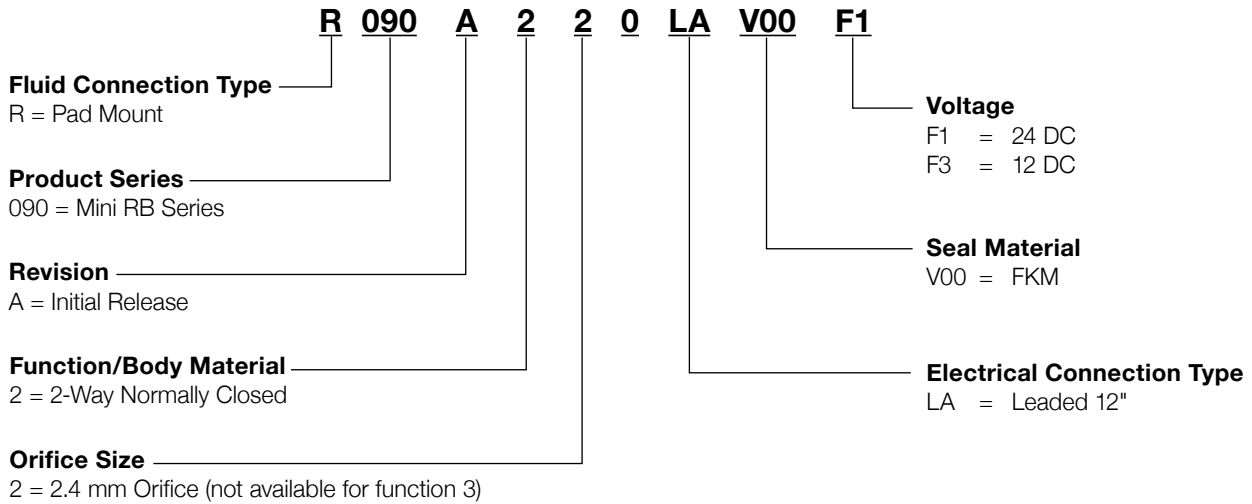

Options

- Other seal materials available on request
- Other voltages and electrical connections available
- Oxygen service

Installation

- The solenoid valves can be mounted in any position without affecting operation.

Dimensions: mm (inches)

2-Way and Pad Mount Solenoid Valve

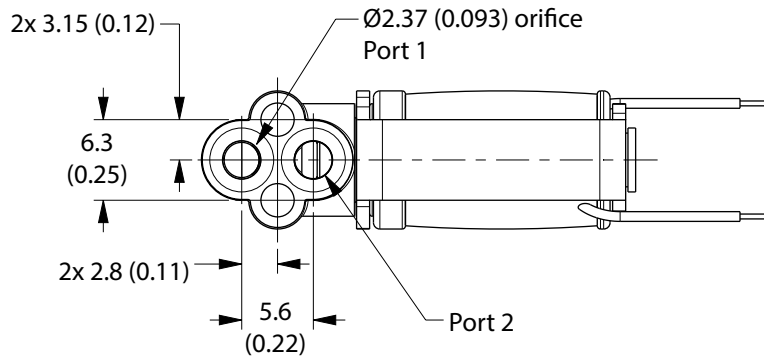
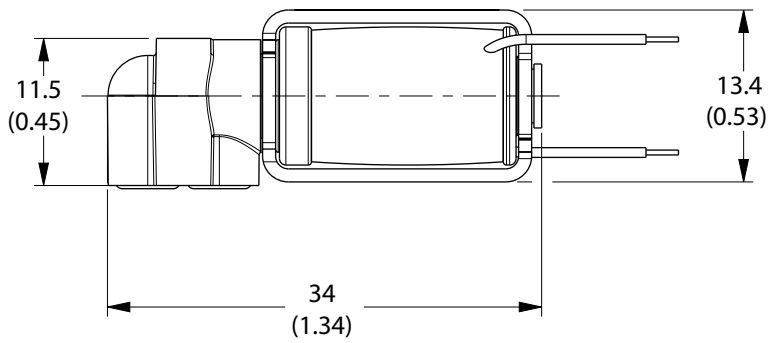
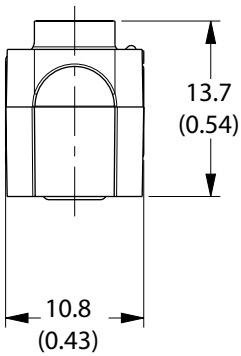
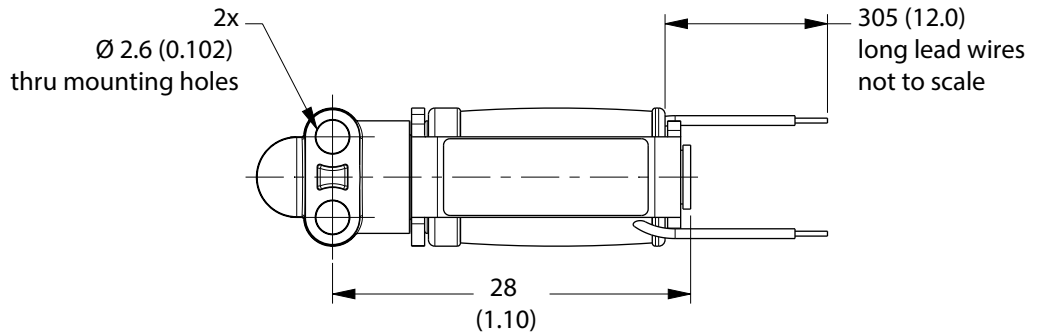

01096GB-2019-R01

Dimensions: mm (inches)

Mounting Pattern for Pad Mount Solenoid Valve

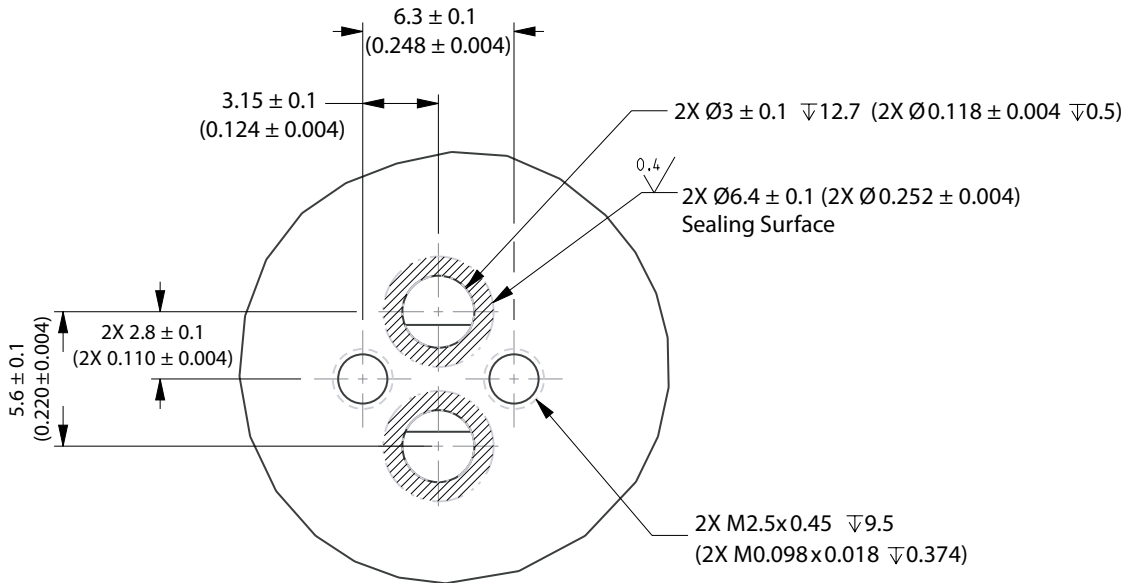

ASCO™ MINIATURE SOLENOID VALVES

GENERAL SERVICE VALVE, COMPACT 2-WAY SOLENOID

- Direct acting solenoid valve for use with air and inert gases
- Manifold mount construction that is suitable for a wide variety of gas application
- Exceptionally long service lifetime ensures maximum reliability
- High-flow design is ideal for quickly inflating / deflating therapeutic air bladders in support surface applications
- Typical applications include
 - Hospital Beds
 - Therapeutic Support Surfaces
 - Endoscopy Drying Systems
 - Deep Vein Thrombosis (DVT)

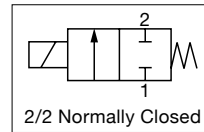

Fluids*	Temperature Range	Seal Materials*
Air, inert gases	0°C to 55°C (32°F to 131°F)	NBR

* Ensure that the compatibility of the materials in contact with the fluids is verified.

General Valve Information	
Body	Stainless Steel

Electrical Characteristics	
Coil Insulation Class	B
Duty Cycle	Intermittent, must use spike and hold noted below
Spike and Hold	Spike at nominal voltage for 500 - 5000 ms max. Hold at 50% of nominal voltage.
Connector	Lead Wires
Connector Specification	28 AWG PVC Insulated
Electrical Enclosure Protection	IP40
Standard Voltages*	12 VDC

* Other voltages on request.

Electrical Connection	Power Ratings		Ambient Temperature Range
	Inrush	Holding	
	W	W	°C (°F)
Lead Wires	7.6	1.9	0 to 55 (32 to 131)

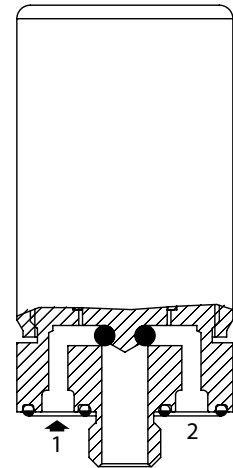

2/2 Normally Closed

Specifications								
Connection	Orifice Size	Flow Coefficient		Operating Pressure bar (psi)		Power Rating (W)		Catalog Number
	mm (inches)	Kv (m ³ /h)	Cv	min.	max.	Inrush	Hold	
2/2 NC - Normally Closed								
1/4-28 UNF Stud Manifold Mount	4.0 (0.16)	2.621	0.387	0 bar (0 psi)	0.34 bar (5 psi)	7.6	1.9	R096A001L0N00V3

01082GB-2019-F01

How to Order

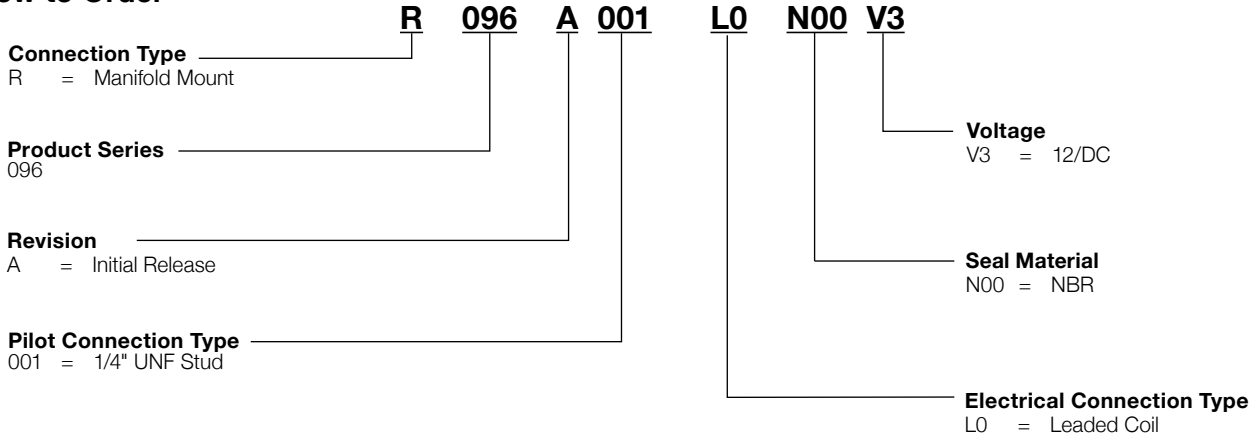

Dimensions: mm (inches)

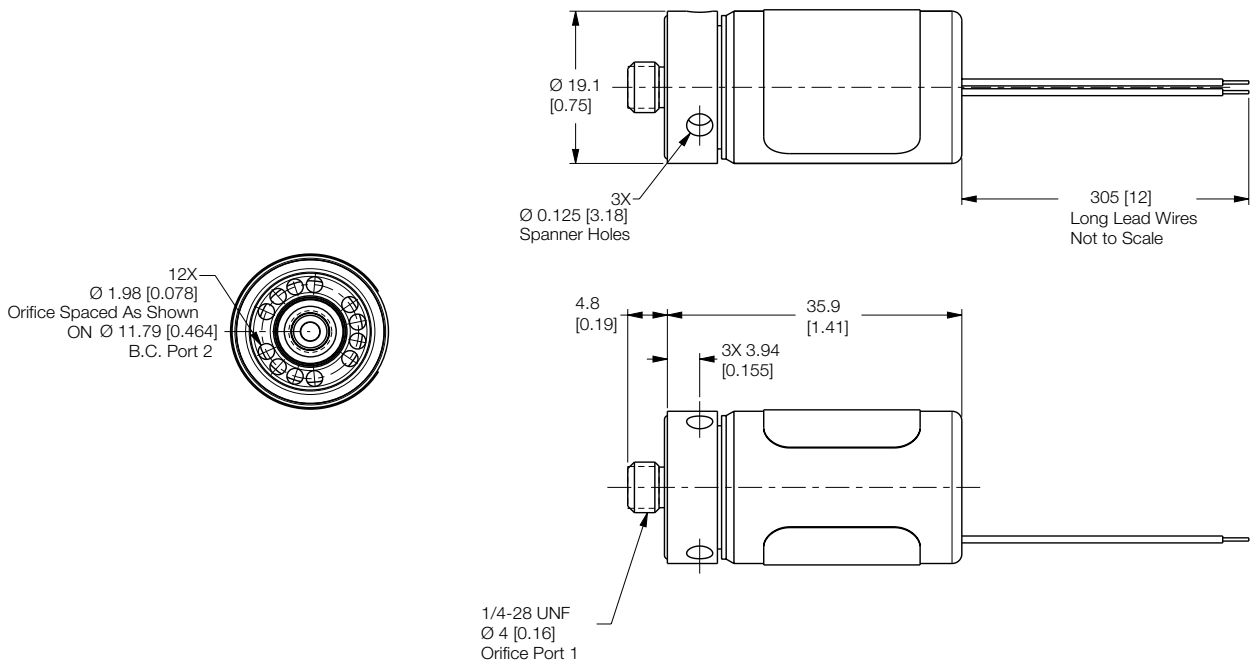

ASCO™ MINIATURE SOLENOID VALVES

GENERAL SERVICE VALVES

SERIES
L123 / L257 / L323

- Direct acting solenoid valve.
- Suitable to shut off liquid and gaseous fluids; suitable for low pressure steam and applications in sterilising autoclaves (verify the compatibility of materials with fluids in contact).
- Typical applications include
 - Dental equipment
 - Steam sterilizers
 - Bio-medical analyzers
 - Low pressure steam

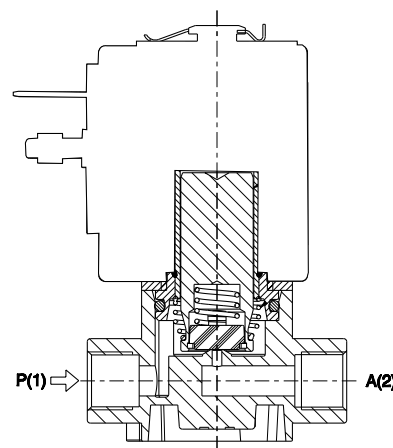
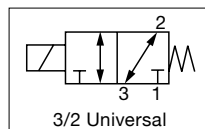
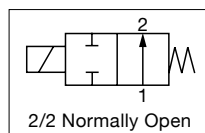
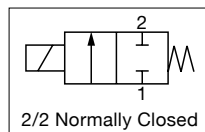

General Valve Information	
Body	PPS
Seals*	FKM
Internal Components	Stainless Steel Stainless Steel and PPS
Seat	PPS
Core Tube	Stainless Steel
Shading coil	Copper
Fluids	Liquids or gases
Fluid temperature	0°C +130°C
Differential pressure	see "Specifications" [1 bar = 100 kPa]
Response time	~ 20ms
Max. Viscosity	37 cSt (mm ² /s)

* Ensure that the compatibility of the materials in contact with the fluids is verified

Electrical Characteristics				
	ZA10A (UL class F - for UL cl.H: ZA34 (E153691))	ZA10B (UL class F - for UL cl.H: ZA34 (E153691))	ZA10G (UL class F - for UL cl.H: ZA34 (E153691))	
Continuous duty	ED 100%	ED 100%	ED 100%	
Coil Insulation Class	F (155°C) on request class H (180°C)	F (155°C)	F (155°C) on request class H (180°C)	
Connector	DIN 46340 - 3 pole connector (EN175301-803)	DIN 46340 - 3 pole connector (EN175301-803)	DIN 46340 - 3 pole connector (EN175301-803)	
Encapsulation material	PPS (polyphenylsulfure) fiberglass reinforced	PET (polyethylene-terephthalate) fiberglass reinforced	PPS (polyphenylsulfure) fiberglass reinforced	
Electrical Enclosure Protection	IP67 (EN60529) with plug connector	IP65 (EN60529) with plug connector	IP67 (EN60529) with plug connector	
Standard Voltages*	DC	12-24 V (+10% -5%)	24V (+10% -5%) (UL)	12-24 V (+10% -5%)
	AC	24V/50Hz - 110V/50Hz (120V/60Hz) - 230V/50Hz (+10% -15%)		

* other voltages and frequencies on request

01094GB-2019-F01

Specifications																					
Pipe Connection	Orifice Size	Flow Coefficient		Operating Pressure, bar				Power Rating (W)			Catalog Number		Sealing Materials*	Notes							
				min.	max.				AC (VA)		DC (W)	Threaded Body									
					Gases		Liquids		Inrush	Holding					Coil						
					AC	DC	AC	DC													
mm	Kv (m ³ /h)	Cv																			
2/2 NC - Normally Closed																					
G1/8	1.6	0.09	0.10	0	10	10	10	10	23	14	9	L123V01	ZA10A	FKM	1,2,3						
	2.3	0.15	0.17		10	10	10	10													
	3.2	0.25	0.29		10	4	10	4													
Barbed ports	1.6	0.09	0.10		10	10	10	10				L123V02			2,3						
	2.3	0.15	0.17		10	10	10	10													
	3.2	0.25	0.29		10	4	10	4													
Barbed ports with ring nut	1.6	0.09	0.10		10	10	10	10				L123V03			2,3,4						
	2.3	0.15	0.17		10	10	10	10													
	3.2	0.25	0.29		10	4	10	4													
Barbed ports	2.3	0.15	0.17		10	10	10	10				L132V04			3,5						
	3.2	0.25	0.29		10	4	10	4													
2/2 NO - Normally Open																					
G1/8	3	0.18	0.21	0	3	3	3	3	23	14	9	L257V02	ZA10A	FKM	1, 3,5						
Barbed ports												L257V01				2,3					
Barbed ports with ring nut		L257V03	2,3,4																		
G1/4	4.2	0.33			0.38	2.5	2.5	2.5				2.5			23	14	10	L257V04	ZA10A	1,3	
			2.5			2.5	2.5	2.5				23			14	10	L257V05	ZA10B			
Barbed ports		0.26	0.30		2.5	2.5	2.5	2.5				23			14	10	L257V05	ZA10A	3		
					2.5	2.5	2.5	2.5				23			14	10	L257V05	ZA10B			
Barbed ports		2.5	0.14		0.16	5	5	5				5			23	14	9	L257V06	ZA10A		2,3
		3	0.18		0.21	3	3	3				3									
3/2 U - Universal																					
G1/8	2.3	0.2	0.23		0	4	4								23	14		L323V01G	ZA10A	FKM	1,2,3
Barbed ports						4	4	4				23			14		12		ZA10G		
				Barbed ports with ring nut		0.12	0.14	4	4	4	4	23	14	12	L323V02G	ZA10A	2,3				
4								4	4	4	23	14	12	L323V03G	ZA10G						
Barbed ports				0.2		0.23	4	4	4	4	23	14		12	L323V04G	ZA10A	2,3				
							4	4	4	4	23	14	12	L323V04G	ZA10G						

* Sealings: FKM = Fluoro-carbon elastomer

1 Maximum driving torque of the pipe fittings for thread connections = 2Nm

2 Only for use with steam, consider following values: PSmax 2.8 bar (max fluid temperature 130°)

3 The pressure values shown in the table refer to the potential of the valve: they can be lower depending on the connection system used

4 Maximum driving torque of ring nut 1.2Nm

5 Only for use with steam, consider following values: PSmax 2.8 bar (max fluid temperature 130°)

ASCO™ MINIATURE SOLENOID VALVES

GENERAL SERVICE VALVES

SERIES
L123/L257/L323

Dimensions: mm (inches)

L123V01

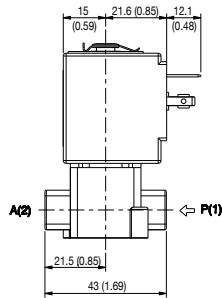
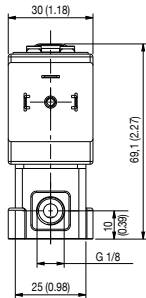
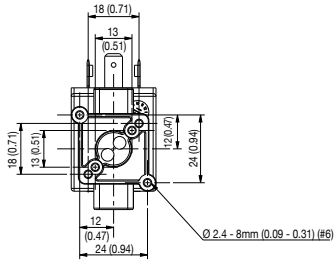

L123V02

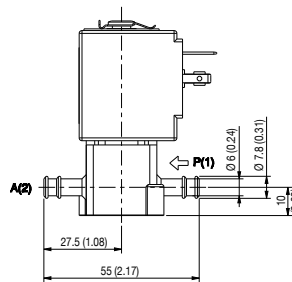

L123V03

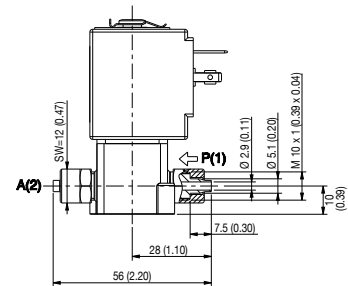

L123 V04

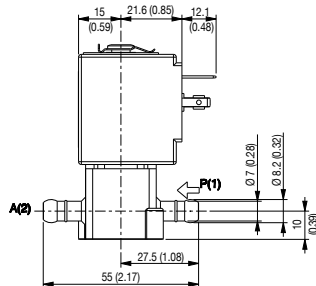
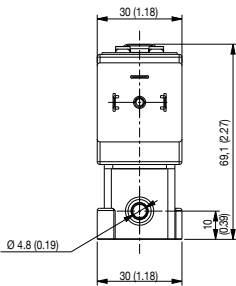
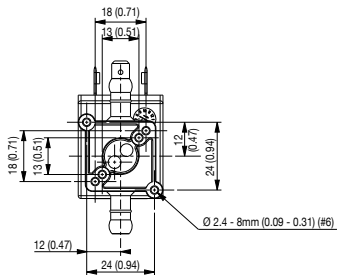

01094GB-2019-R01

Dimensions: mm (inches)

L257V02

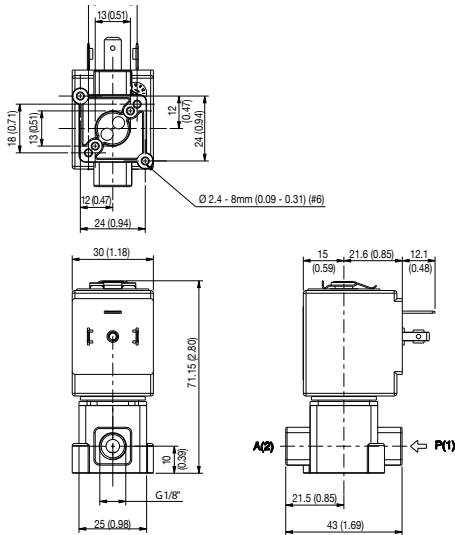

L257V01

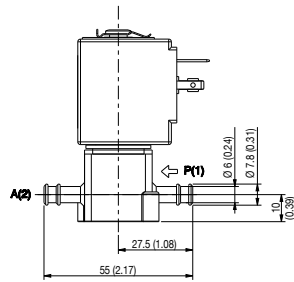

L257V03

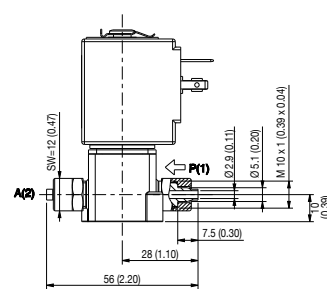

L257V04

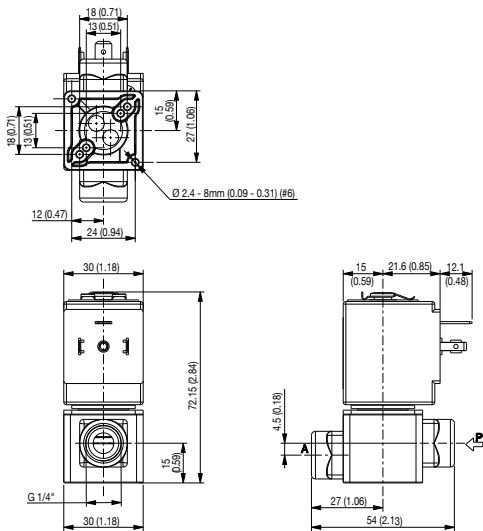

L257V05

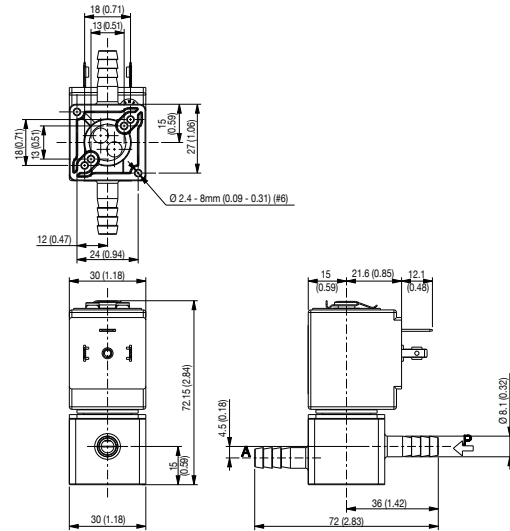

ASCO™ MINIATURE SOLENOID VALVES

GENERAL SERVICE VALVES

SERIES
L123/L257/L323

Dimensions: mm (inches)

L257V06

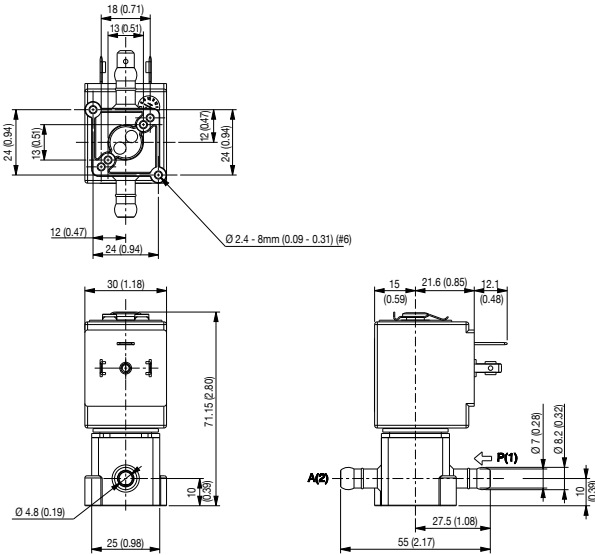

L323V01G

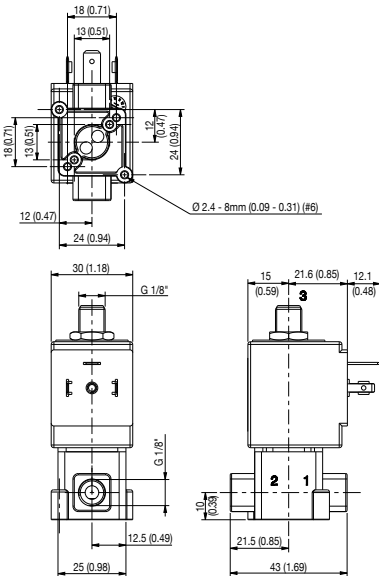

L323V02G

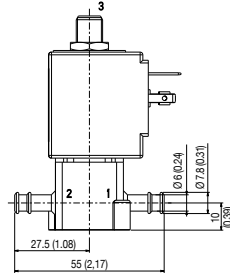

L323V03G

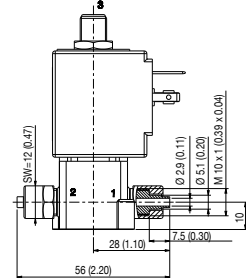

01094GB-2019-R01

Dimensions: mm (inches)

L323-V04G

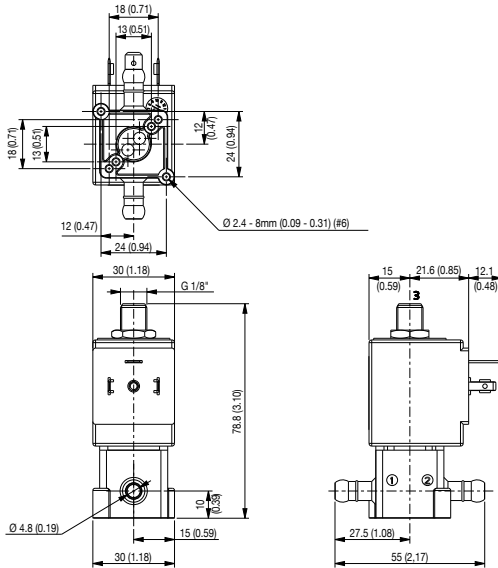

Spare Part Kits

L123-V01/V02/V03/V04

Kit description	Kit P.N.	Consisting of:
Core kit	G3139401	Core
Core return spring kit	G3022401	N.10 core return spring
O-Ring guide assembly kit	GU2428000017	N.10 O-Ring guide assembly
Guide assembly kit	G31487	Guide assembly Coil clip
Coil	ZA10A	Coil

L257-V01/V02/V03

Kit description	Kit P.N.	Consisting of:
Core kit	G3138301	Core return spring Core O-Ring guide assembly Pusher Sealing disc return spring Sealing disc
Core return spring kit	G290513-001	N°.10 Core return spring
O-Ring guide assembly kit	GU2428000015	N°.10 OR guide assembly
Guide assembly kit	G31488	Guide assembly Coil clip
Coil	ZA10A	Coil

L257-V04 / L257-V05

Kit description	Kit P.N.	Consisting of:
Core kit	G3138301	Core return spring Core O-Ring guide assembly Pusher Sealing disc return spring Sealing disc
Core return spring kit	G290513-001	N°.10 Core return spring
O-Ring guide assembly kit	GU2428000015	N°. 10 OR guide assembly
Guide assembly kit	G31488	Guide assembly Coil clip
Coil	ZA10A ZA10B	Coil

L257-V06

Kit description	Kit P.N.	Consisting of:
Core kit	G3138301	Core return spring Core O-Ring guide assembly Pusher Sealing disc return spring Sealing disc
Core return spring kit	G290513-001	N°.10 Core return spring
O-Ring guide assembly kit	GU2428000015	N°. 10 OR guide assembly
Guide assembly kit	G31488	Guide assembly Coil clip
Coil	ZA10A	Coil

L323-V01G/V02G/V03G/V04G

Kit description	Kit P.N.	Consisting of:
Core kit	G3065101	Core
Core return spring kit	G3022401	N.10 core return spring
O-Ring guide assembly kit	GU2428000017	N.10 O-Ring guide assembly
Guide assembly	290564-001R	Guide assembly
Coil	ZA10A ZA10G	Coil

Installation

- Solenoid valve can be mounted in any position; vertical with coil upwards preferred.
- When using any sealant for fittings, please check its chemical compatibility with body material (PPS).
- In case of disassembling for usual maintenance, the fixing screws of the guide assembly have to be tightened with 0.6±0.7 Nm torque.

01094GB-2019-F01

ASCO™ MINIATURE SOLENOID VALVES

GENERAL SERVICE VALVES, MINIATURE SOLENOID

- The 188 Series solenoid valves are designed for use with air and inert gases, and can also be used to pilot other valves or cylinders
- Compact architecture and low power consumption of only 1.3 W make them ideal for portable medical devices
- Also available in a 1 W version for increased versatility
- LED visual indicator and electrical protection circuitry are standard features
- Meets all relevant CE directives, and is RoHS compliant
- Typical applications include:
 - Respiratory Therapy
 - Dental
 - Anesthesia Delivery
 - Industrial Gas Analyzers

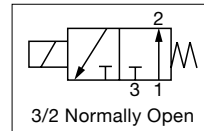
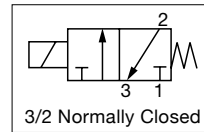

Fluids	Temperature Range	Seal Materials
Air or Inert Gas, non-lubricated ¹	5 °C to 50 °C (41 °F to 122 °F)	NBR (Nitrile)
		FKM

¹ filtered at 25 µm
NOTE: Additional constructions and options are available including alternate elastomers and orifice sizes. Minimum quantities apply.

General Valve Information	
Body	PA (polyamide) MXD6
Others	Stainless steel, nickel-plated steel, synthetic material, aluminum
Response Time	< 10ms
Options	Oxygen clean available 300 Series Stainless Steel Body

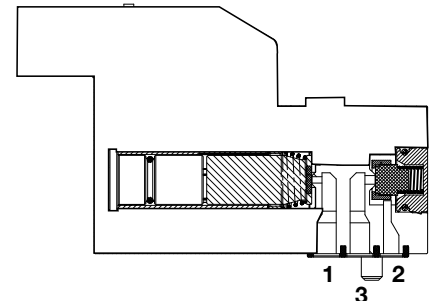

3/2 NC or 3/2 NO Function
Pad Mount Body

Electrical Characteristics	
Standard Voltages*	5 VDC, 12 VDC, 24 VDC (-15%/+10%)
Power Consumption	1 - 1.3 W

* Other voltages on request
NOTE: The solenoid valves are designed for continuous operation within the maximum ambient temperature limits.

Insulation Class	Coil Insulation	Protection	Ambient Temperature Range	Electrical Connection
	°C (°F)	VA	°C (°F)	
F	155 (311)	IP40	5 to 50 (41 to 122)	Connector with two 0.5mm ² lead wires + built-in LED and electrical protection or lead wires, 0.5m (19.7in) long

00217GB-2019-R01

Specifications								
Orifice Size		Flow Coefficient		Operating Pressure bar (psi)		Power Rating W	Type of Electrical Connection*	Catalog Number
mm (inches)		Kv (m ³ /h)	Cv	min.	max. gases, liquids			
1 → 2	2 → 3							
3/2 NC - Normally Closed								
0.5 (0.020)	0.7 (0.028)	0.006	0.007	0	8 (116)	1.3	01	18801003
							02	18801076
							03	18801074
							04	18801078
							1	18801072
0.8 (0.031)	0.8 (0.031)	0.007	0.008	0	4 (58)	1.3	01	18801081
							02	18801082
							03	18801083
							04	18801084
							1	18801085
1.0 (0.040)	1.0 (0.040)	0.011	0.013	0	2.5 (36)	1.3	01	18801086
							02	18801087
							03	18801088
							04	18801089
							1	18801090
3/2 NO - Normally Open								
0.5 (0.020)	0.5 (0.020)	0.006	0.007	0	6 (87)	1.3	01	18801063
							02	18801077
							03	18801075
							04	18801079
							1	18801073
0.8 (0.031)	0.8 (0.031)	0.007	0.008	0	3 (43.5)	1.3	01	18801091
							02	18801092
							03	18801093
							04	18801094
							1	18801095
1.0 (0.040)	1.0 (0.040)	0.011	0.013	0	1.5 (21.8)	1.3	01	18801096
							02	18801097
							03	18801098
							04	18801099
							1	18801100

* Type 01, 02, 03, 04 with LED and electrical protection
 01 = horizontal, width 5.08mm (0.2in)
 02 = vertical, width 5.08mm (0.2in)

03 = horizontal, width 2.54mm (0.1in)
 04 = vertical, width 2.54mm (0.1in)
 05 = cable ends 0.5m long (19.7in), 0.25mm²

Dimensions: mm (inches)

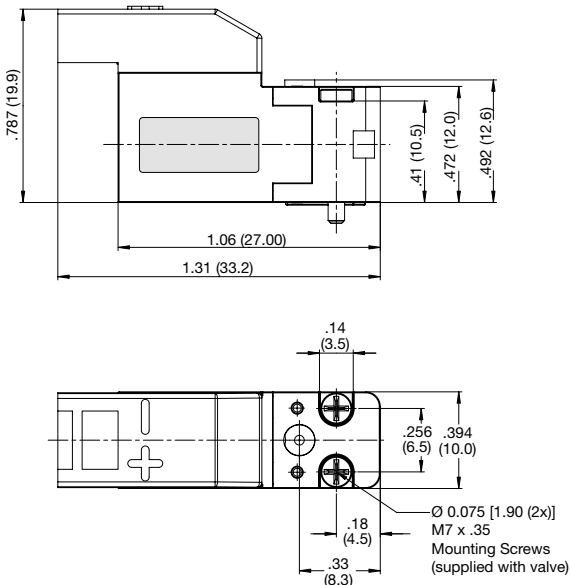

NOTE: The connectors to be ordered separately.
Includes one connector with two wires.

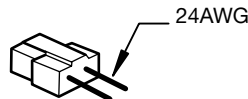

Length	Catalog Number
20" (0.5m)	88118801
59" (1.5m)	88118802
118" (3m)	88118803

00217GB-2019-R01

ASCO™ MINIATURE SOLENOID VALVES

GENERAL SERVICE VALVES, MINIATURE SOLENOID

Dimensions: mm (inches)

Valve Mounted on Single Subbase

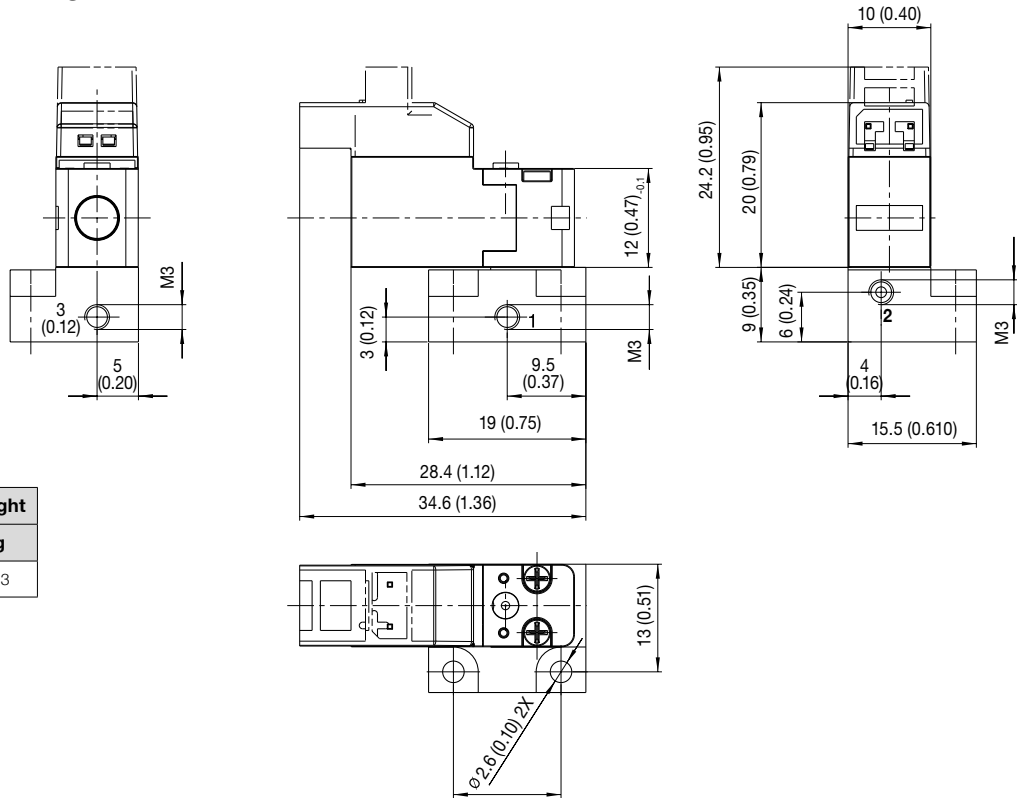

Number of Valves	Subbase Catalog Number	Weight kg
1	35300101	2.53

Manifold Interface

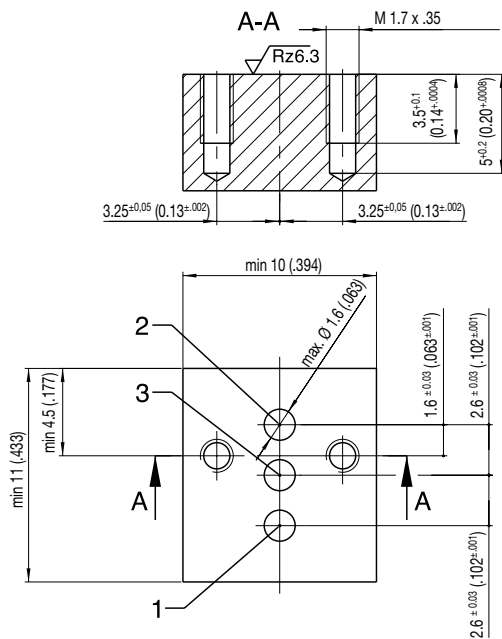

00217GB-2019-R02

ASCO™ MINIATURE SOLENOID VALVES

GENERAL SERVICE VALVES, MINIATURE SOLENOID WITH LATCHING COIL

- The 188 Series latching coil solenoid valves are designed for use with air and inert gases, and can also be used to pilot other valves or cylinders
- The benefit of the latching coil is that no power consumption is needed to hold the valve in the open position
- Compact architecture and low power consumption of only 1.3 W make them ideal for portable medical devices
- Also available in a 1 W version for increased versatility
- LED visual indicator and electrical protection circuitry are standard features
- Meets all relevant CE directives, and is RoHS compliant
- Typical applications include:
 - Respiratory Therapy
 - Dental
 - Anesthesia Delivery
 - Industrial Gas Analyzers

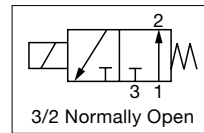
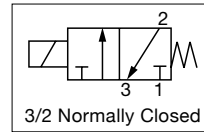

Fluids	Temperature Range	Seal Materials
Air or Inert Gas, non-lubricated ¹	5 °C to 50 °C (41 °F to 122 °F)	NBR (Nitrile)
		FKM

¹ filtered at 25µm

General Valve Information*	
Body	PA (polyamide) MXD6
Others	Stainless steel, nickel-plated steel, synthetic material, aluminum
Response Time	< 10ms
Options	Oxygen clean available 300 Series Stainless Steel Body

* Other materials on request

Electrical Characteristics	
Standard Voltages*	5 VDC, 12 VDC, 24 VDC (-15%/+10%)
Power Consumption	1 - 1.3 W

* Other voltages on request

Insulation Class	Coil Insulation	Protection	Ambient Temperature Range	Electrical Connection
	°C (°F)		VA	
F	155 (311)	IP40	5 to 50 (41 to 122)	Connector with two 0.5mm ² lead wires + built-in LED and electrical protection or lead wires, 0.5m (19.7in) long

Specifications								
Orifice Size mm (inches)		Flow Coefficient Kv (m ³ /h) Cv		Operating Pressure bar (psi)		Power Rating W	Type of Electrical Connection*	Catalog Number
				min.	max. gases, liquids			
1 → 2	2 → 3							
3/2 NC/NO								
0.5 (0.020)	0.7 (0.028)	0.007	0.008	0	7 (101)	1.3	01	18801101
							02	18801102
							03	18801103
							04	18801104
							05	18801105
0.8 (0.031)	0.8 (0.031)	0.009	0.010	0	3 (43.5)	1.3	01	18801106
							02	18801107
							03	18801108
							04	18801109
							05	18801110
1.0 (0.040)	1.0 (0.040)	0.011	0.013	0	1 (14.5)	1.3	01	18801111
							02	18801112
							03	18801113
							04	18801114
							05	18801115

* Type 01, 02, 03, 04 with LED and electrical protection
01 = horizontal, width 5.08mm (0.2in)
02 = vertical, width 5.08mm (0.2in)

03 = horizontal, width 2.54mm (0.1in)
04 = vertical, width 2.54mm (0.1in)
05 = cable ends 0.5m long (19.7in), 0.25mm²

Wiring Diagram

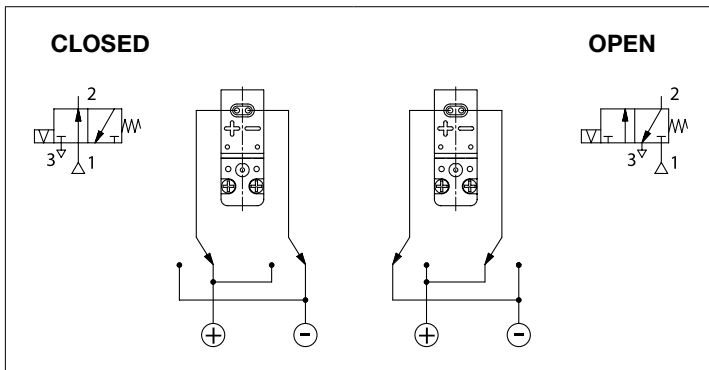

Functional Diagram

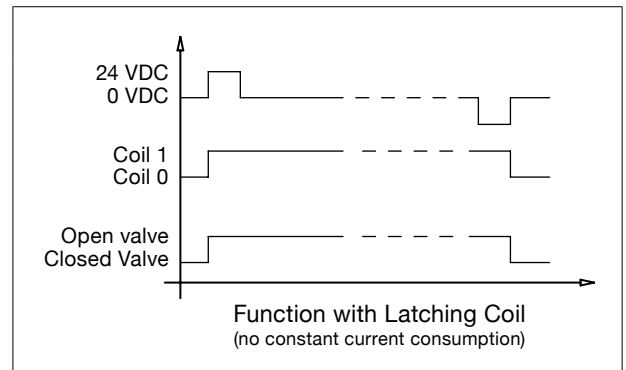

ASCO™ MINIATURE SOLENOID VALVES

GENERAL SERVICE VALVES, MINIATURE SOLENOID WITH LATCHING COIL

SERIES
188

Dimensions: mm (inches)

Type 01

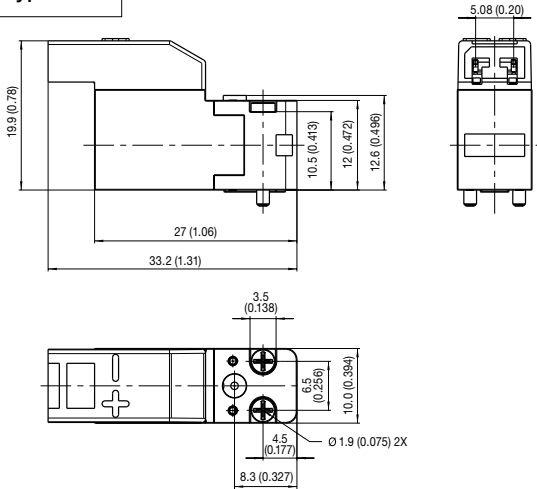

Type 02

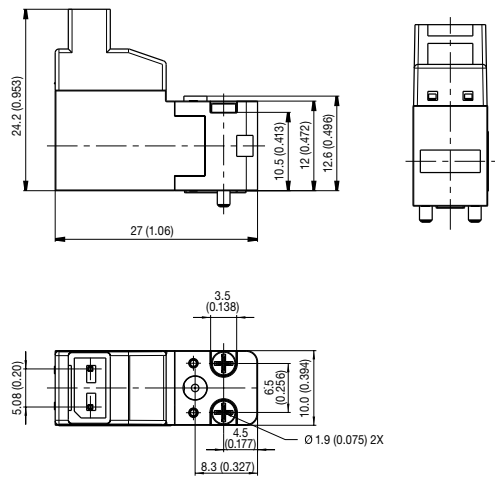

Type 03

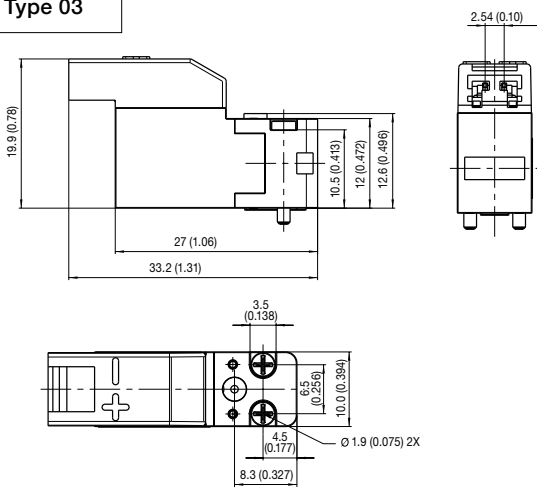

Type 04

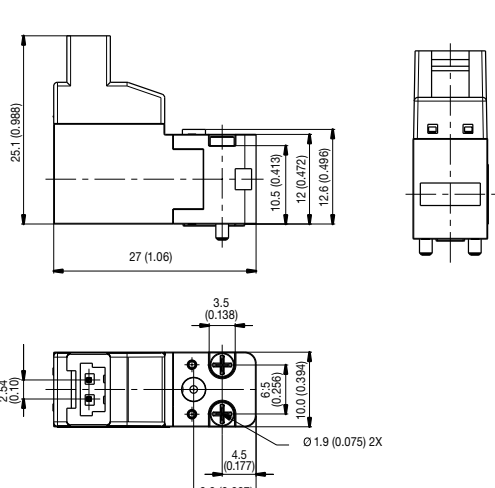

Type 05

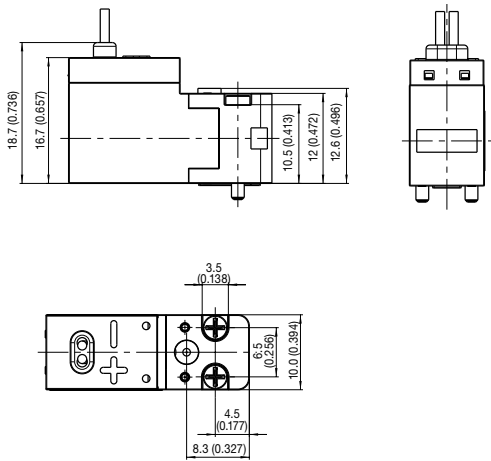

Flange Facing

NO
3 = Pressure
2 = Outlet
1 = Exhaust
NC
1 = Pressure
2 = Outlet
3 = Exhaust
Use in vacuum (NO)
3 = Vacuum pump
2 = Outlet
1 = Atmosphere
Use in vacuum (NC)
1 = Vacuum pump
2 = Outlet
3 = Atmosphere

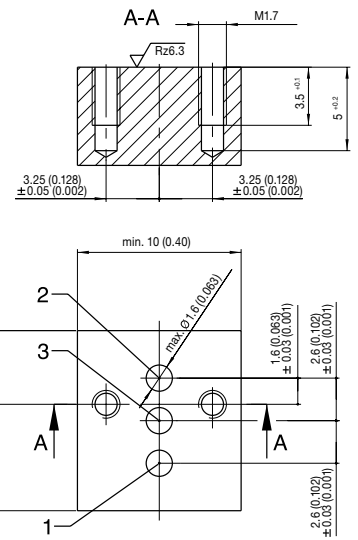

00217GB-2019-R01

Dimensions: mm (inches)

Solenoid Valve Mounted on Single Subbase

Number of Valves	Subbase Catalog Number	Weight
		kg
1	35300101	0.015

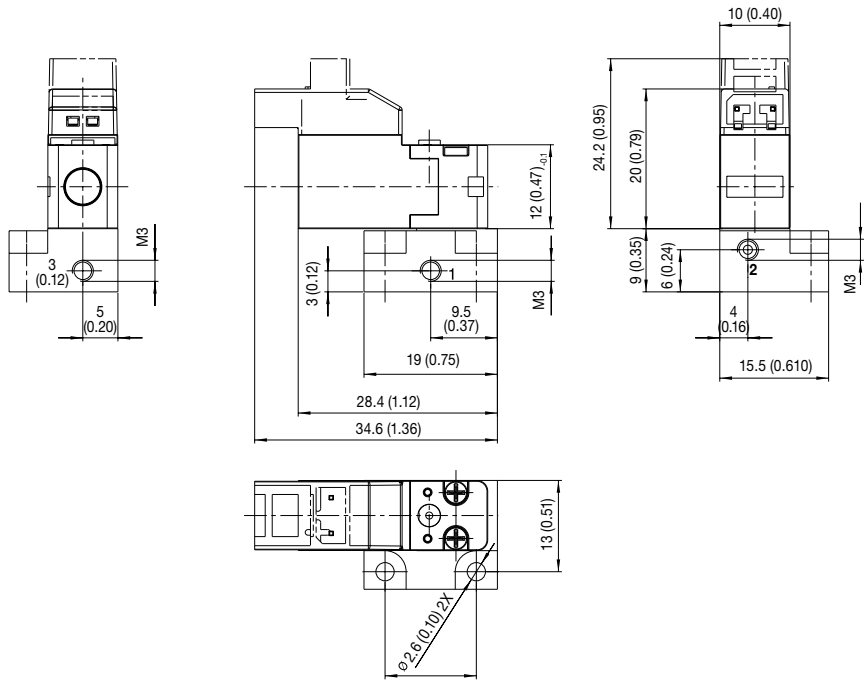

Solenoid Valve Mounted on Multiple Subbase

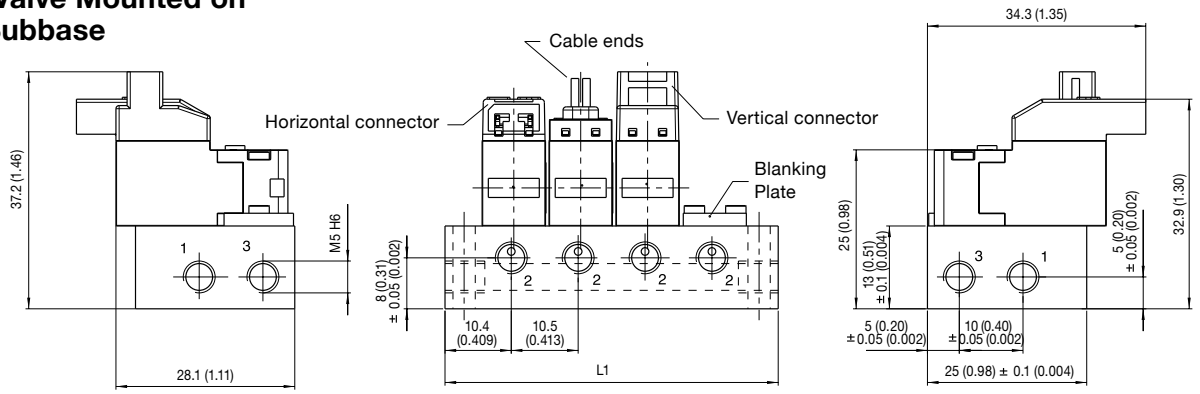

Number of Valves	Subbase Catalog Number*	Length	
		L1	L2
2	35300102	33.5 (1.32)	27.5 (1.08)
3	35300103	44 (1.73)	38 (1.50)
4	35300104	54.5 (2.15)	48.5 (1.91)
5	35300105	65 (2.56)	59 (2.32)
6	35300106	75.5 (2.97)	69.5 (2.74)
7	35300107	86 (3.39)	80 (3.15)
8	35300108	96.5 (3.80)	90.5 (3.56)
9	35300109	107 (4.21)	101 (3.98)
10	35300110	117.5 (4.63)	111.5 (4.39)

A : Blanking plate, cat. number 88135305

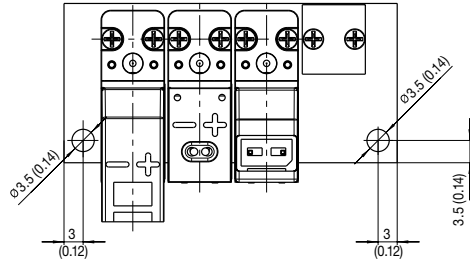

NOTE:

The connectors must be ordered separately, please indicate the quantity and one of the following codes:
Connector, 2 wires:

- Distance between contacts 5.08mm (0.2in)
- Length 0.5m (19.7in) - cat. no.: **88118801**
- Length 1.5m (59.1in) - cat. no.: **88118802**
- Length 3m (118in) - cat. no.: **88118803**
- Distance between contacts 2.54mm (0.1in)
- Length 0.5m (19.7in) - cat. no.: **88118806**
- Length 1.5m (59.1in) - cat. no.: **88118807**
- Length 3m (118in) - cat. no.: **88118808**

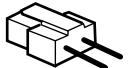

ASCO™ MINIATURE SOLENOID VALVES

GENERAL SERVICE VALVES, 3-WAY UNIVERSAL

- The Series 226 3-way direct acting solenoid valve can be used with both liquids and gases
- Low power consumption, as well as latching coil versions, results in a decrease in OEM instrument power consumption as well as a decrease in heat transferred to the fluid media
- Small form-factor saves space in OEM instruments and are well-suited for portable and hand-held field devices
- Multiple electrical connection options offer greater flexibility in OEM instrument design and serviceability
- Meets all relevant CE directives, and is RoHS compliant
- Typical applications include:
 - Dental Equipment
 - Gas Chromatography
 - Industrial Analyzers
 - Respiratory Devices

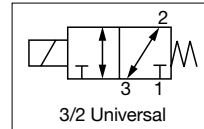
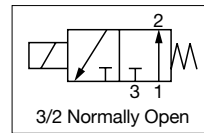
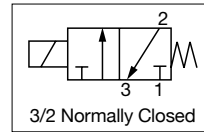

Fluids*	Temperature Range	Seal Materials*
Liquids and gases	-10°C to 90°C (14°F to 194°F) (NBR) 0°C to 90°C (32°F to 194°F) (FKM)	NBR or FKM

* Ensure that the compatibility of the materials in contact with the fluids is verified.

General Valve Information	
Body	Brass
Internal components	Brass, PEI (Polyetherimide) and stainless steel
Seat	1 ↔ 2: Brass - 1 ↔ 3: PEI
Core tube	Brass
Maximum allowable pressure (PS)	16 bar (232 psi)
Response Time	<10ms
Max viscosity	3°E (22 cStokes or mm ² /s)

Electrical Characteristics	
Continuous duty	ED 100%
Encapsulation material	PA (Polyamide) fiberglass reinforced
Insulation class	F (155°C)
Ambient temperature	-10°C to 60°C (14°F to 140°F)
Electric connection*	DIN 46340 – micro plug connector
Electrical Enclosure Protection	IP 65 (EN 60529) with micro plug connector
Standard Voltages	DC: 12 VDC, 24 VDC (+10% - 5%)

* leaded coil on request

NOTE:

These micro-solenoid valves are not suitable for stagnating media subject to vaporization which deposit solid, calcareous, incrusting residues or similar. Sealings: NBR = Nitrile Butadiene Rubber FKM = Fluoro-carbon elastomer.
1 - For reference, F1 = 24 VDC; F3 = 12 VDC

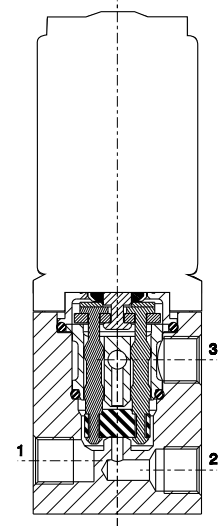

01075GB-2019-R01

Specifications																	
Port size ISO UNI 4534	Orifice Size mm (inches)	Operating Pressure, bar (psi)						Kv (m ³ /h)	Cv	Power Absorption			Sealings	Catalog Number	Voltage		
		Δp min	Δp max				AC			DC	AC (VA)				DC (W)	12V DC	24V DC
			Gases		Liquids						Inrush	Holding					
			AC	DC	AC	DC											
M5	1.2 (0.047)	0	-	-	-	-	0.04	0.05	-	-	2.5	NBR	H226A556S0A00	F3	F1		
													H226A557S0A00	F3	F1		
													H226A559S0A00	-	F1		
													H226A560S0A00	-	F1		
													H226A566S0A00	-	F1		
													H226A562S0A00	-	F1		
	2 (0.079)	0	-	-	-	-	0.08	0.09	-	-	4	FKM	H226A562S0A00	-	F1		
													NBR	H226A558S0A00	-	F1	
													H226A567S0A00	F3	-		
													FKM	H226A563S0A00	F3	-	

Dimensions: mm (inches)

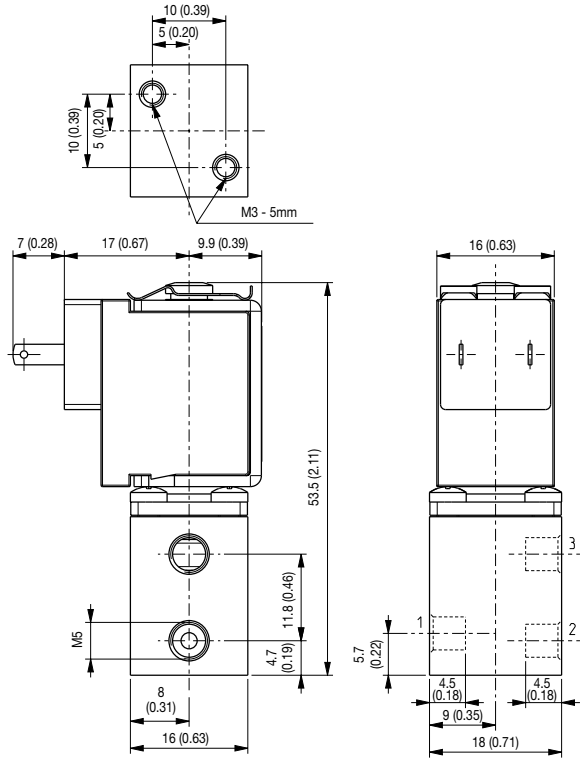

Installation

Solenoid valve can be mounted in any position; vertical with coil upwards preferred.

NOTE:
It is necessary to keep the current circulating in the coil constant, so as to maintain the solenoid valve in any pre-determined position. In case the solenoid valve is energised by voltage variation, it has to be considered that the resistance of winding increases because of the continued energizing and consequently the power decreases. Therefore, it is necessary to compensate such power decrease by increasing the voltage to re-establish the initial current value.

01075GB-2019-R01

ASCO™ MINIATURE SOLENOID VALVES

GENERAL SERVICE VALVES, 2-WAY NORMALLY OPEN

- The Series 226 direct acting solenoid valve can be used with both liquids and gases
- Low power versions (0.5W), and latching coil versions (power consumption close to zero) results in a decrease in OEM instrument power consumption as well as a decrease in heat transferred to the fluid media
- Small form-factor saves space in OEM instruments and are well-suited for portable and hand-held field devices
- Multiple electrical connection options offer greater flexibility in OEM instrument design and serviceability
- Meets all relevant CE directives, and is RoHS compliant
- Typical applications include:
 - Dental Equipment
 - Gas Chromatography
 - Industrial Analyzers
 - Respiratory Devices

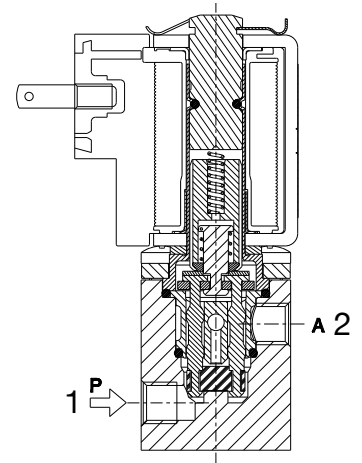
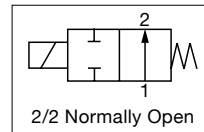

Fluids*	Temperature Range	Seal Materials*
Liquids and gases	-10°C +90°C (14°F to 194°F)	NBR

* Ensure that the compatibility of the materials in contact with the fluids is verified.

General Valve Information	
Body	Brass
Sealing	NBR
Internal components	Brass, PEI (Polyetherimide) and stainless steel
Seat	PEI
Core tube	Brass
Maximum allowable pressure (PS)	16 bar (232 psi)
Response Time	<10ms
Fluid temperature	-10°C +90°C (14°F to 194°F)
Max viscosity	3°E (22 cStokes or mm ² /s)

Electrical Characteristics	
Continuous duty	ED 100%
Encapsulation material	PA (Polyamide) fiberglass reinforced
Coil insulation class	F (155°C)
Ambient temperature	-10°C to 60°C (14°F to 140°F)
Electric connection*	DIN 46340
Electrical Enclosure Protection	IP 65 (EN 60529) with micro plug connector
Voltages DC	12 VDC, 24 VDC (-5%/+10%)

* leaded coil on request

Specifications																	
Port size ISO-UNI 4534	Orifice Size (mm)	Operating Pressure, bar (psi)						Flow Coefficient		Power absorption			Seals	Catalog Number		Voltage	
		Δp min	Δp max				Kv (m ³ /h)	Cv	AC. (VA)		DC. (W)	Valve		12V DC	24V DC		
			Gases		Liquids				Inrush	Holding							
			AC	DC	AC	DC											
M5	1 (0.039)	0	-	10 (145)	-	10 (145)	0.04	0.05	-	-	4	NBR	H226A554S0A00	F3	-		
	2 (0.079)		-	3.5 (51)	-	3.5 (51)	0.10	0.12	-	-			H226A555S0A00	F3	-		

NOTE:

These micro-solenoid valves are not suitable for stagnating media subject to vaporization which deposit solid, calcareous, incrusting residues or similar.
 Seal: NBR = Nitrile Butadiene Rubber
 1 - For reference, F1 = 24 VDC; F3 = 12 VDC

01076GB-2019-R01

Dimensions: mm (inches)

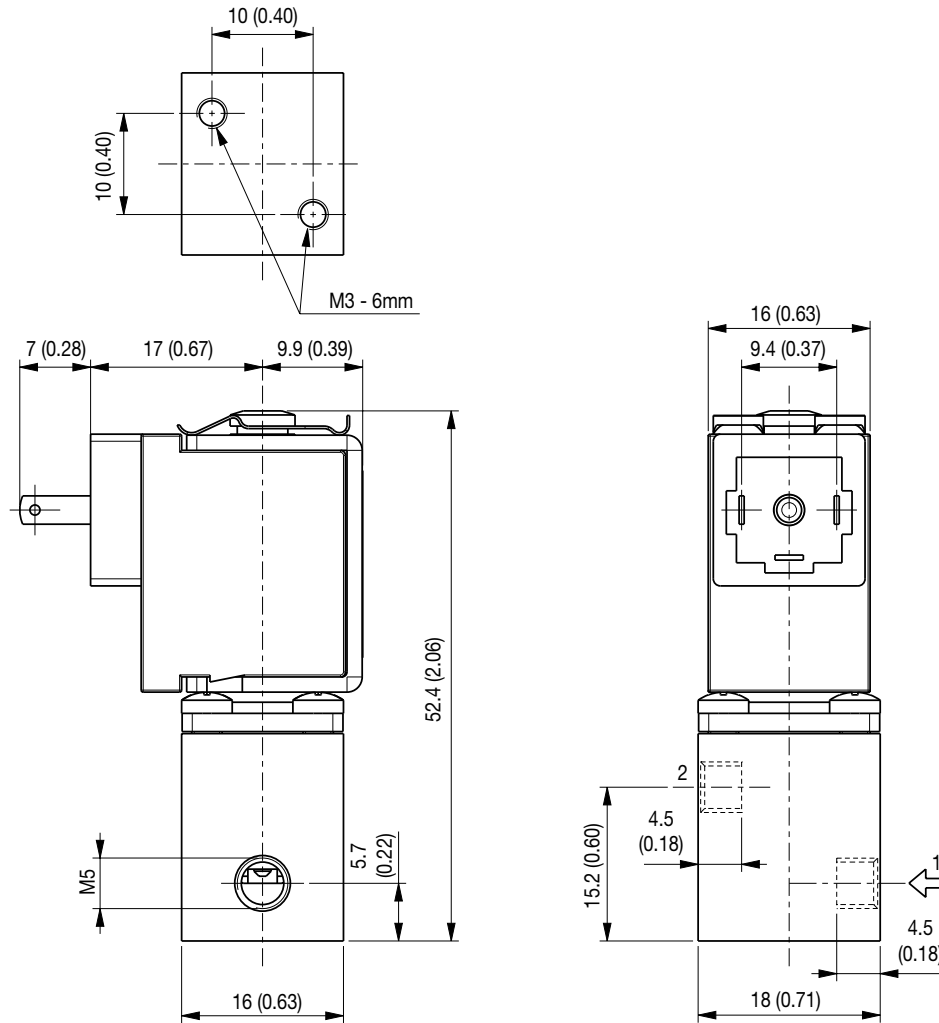

Mounting

- Solenoid valve can be mounted in any position; vertical with coil upwards preferred.

ASCO™ MINIATURE SOLENOID VALVES

GENERAL SERVICE VALVES, 2-WAY NORMALLY CLOSED - HIGH PRESSURE

- The Series 226 direct acting solenoid valve can be used with both liquids and gases
- Low power versions (0.5W), and latching coil versions (power consumption close to zero) results in a decrease in OEM instrument power consumption as well as a decrease in heat transferred to the fluid media
- Small form-factor saves space in OEM instruments and are well-suited for portable and hand-held field devices
- Multiple electrical connection options offer greater flexibility in OEM instrument design and serviceability
- Meets all relevant CE directives, and is RoHS compliant
- Typical applications include:
 - Dental Equipment
 - Gas Chromatography
 - Industrial Analyzers
 - Respiratory Devices

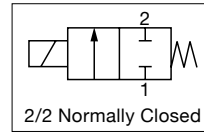

Fluids*	Temperature Range	Seal Materials*
Liquids and gases	0°C to 130°C (32°F to 266°F) (FKM) 0°C to 140°C (32°F to 284°F) (FFKM) -10°C to 90°C (14°F to 194°F) (HNBR)	FKM or FFKM or HNBR

* Ensure that the compatibility of the materials in contact with the fluids is verified.

General Valve Information	
Body	Brass
Internal components	Stainless Steel
Maximum allowable pressure (PS)	16 bar (232 psi)
Response Time	<10ms
Max viscosity	3°E (22 cStokes or mm ² /s)
Guide assembly	Stainless Steel

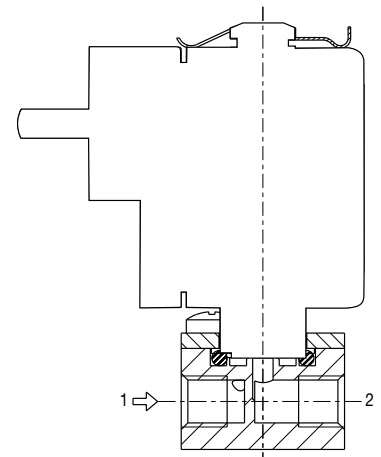

Electrical Characteristics	
Continuous duty	ED 100%
Encapsulation material	PA (Polyamide) fiberglass reinforced
Coil insulation class	F (155°C)
Ambient temperature	-10°C to 60°C (14°F to 140°F)
Electric connection*	DIN 46340
Electrical Enclosure Protection	IP65 (EN 60529) with plug micro-connector
Standard Voltages	DC: 12 VDC, 24 VDC (+10% - 5%)

* leaded coil on request

NOTE:

These micro-solenoid valves are not suitable for stagnating media subject to vaporization which deposit solid, calcareous, incrusting residues or similar. Seal: FKM = Fluoro-carbon elastomer FFKM = Perfluorated elastomer HNBR = Hydrogenated nitrile-butylene elastomer

01077GB-2019-R01

Specifications																							
Con- nection	Orifice Size mm (inches)	Operating Pressure bar (psi)				Kv (m ³ /h)	Cv	Power Rating			Sealings	Catalog Number	Voltage										
		Δp min	Δp max					AC (VA)		DC (W)			12V DC	24V DC									
			Gases		Liquids			Inrush	Holding														
			AC	DC	AC										DC								
M5	1.1 (0.043)	0	-	-	-	-	-	-	-	0.5	FKM	H226A540S0A00	F3	-									
												H226A542S0A00	-	F1									
												H226A541S0A00	F3	F1									
												H226A543S0A00	F3	F1									
	2 (0.079)										-	-	-	-	0.10	0.12	-	-	2.5	FKM	H226A549S0A00	-	F1
																					H226A551S0A00	F3	F1
																				FFKM	H226A552S0X00	-	F1

Dimensions: mm (inches)

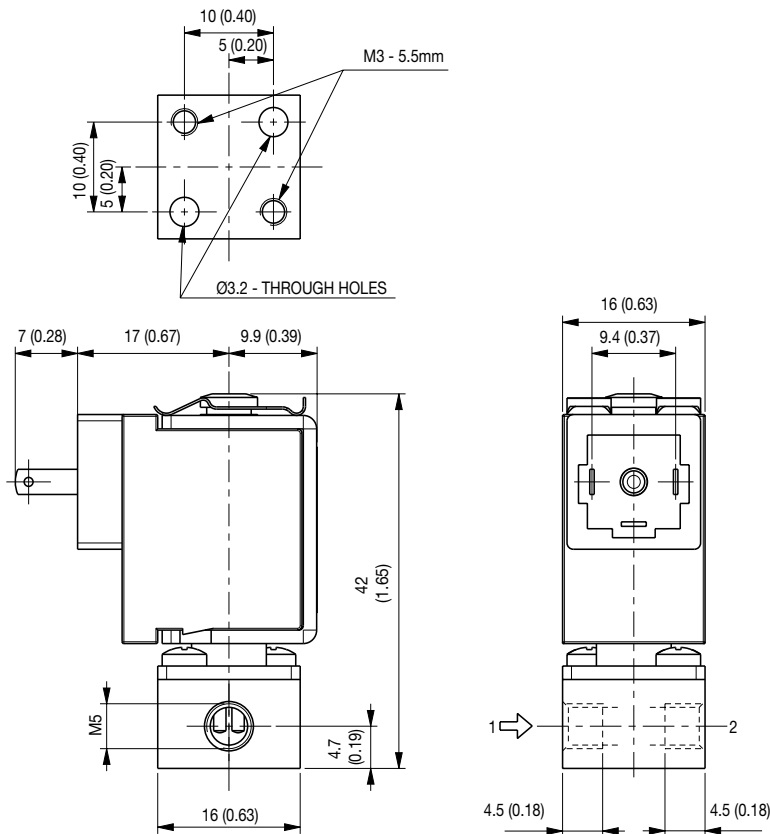

Mounting

- Solenoid valve can be mounted in any position; vertical with coil upwards preferred.

ASCO™ MINIATURE SOLENOID VALVES

GENERAL SERVICE VALVES , 2-WAY NORMALLY CLOSED - PROPORTIONAL INLINE

- Series 226 proportional valves are designed to proportionally control the flow of neutral and aggressive liquids and gases by varying the electrical input signal to the coil
- Optional manual set-screw version available to optimize flow rate / electrical signal
- Reduced heat transfer between control mechanism and fluid make them ideal for use with heat-sensitive reagents and biological samples
- Small form-factor saves space in OEM instruments and are well-suited for portable and hand-held field devices
- Multiple electrical connection options and a rotatable coil create greater flexibility in OEM instrument design and serviceability
- Various connections are available so that the valve can easily be integrated into virtually any fluidic path
- Meets all relevant CE directives, and is RoHS compliant
- Typical applications include:
 - Dental Equipment
 - Gas Chromatography
 - Industrial Analyzers
 - Respiratory Devices

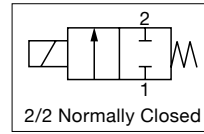

Fluids*	Temperature Range	Seal Materials*
Liquids and gases	-10°C +90°C (14°F to 194°F)	NBR

* Ensure that the compatibility of the materials in contact with the fluids is verified.

General Valve Information	
Body	Brass
Internal components	Stainless steel
Seat	Brass
Core tube	Stainless steel
Maximum allowable pressure (PS)	16 bar (232 psi)
Max viscosity	3°E (22 cStokes or mm ² /s)

Electrical Characteristics	
Continuous duty	ED 100%
Encapsulation material	PA (Polyamide) fiberglass reinforced
Insulation class	F (155°C)
Ambient temperature	-10°C to 60°C (14°F to 140°F)
Electric connection ¹	DIN 46340
Protection degree	IP 65 (EN 60529) with micro plug connector
Voltages ²	12 VDC, 24 VDC (-5%/+10%)

¹ leaded coil on request
² other voltages on request.

Specifications												
Port size ISO-UNI 4534	Orifice Size (mm)	Operating Pressure bar (psi)		Flow Coefficient		Power Rating			Seals	Series and Type Valve	Voltage	
						AC. (VA)		DC. (W)			12V DC	24V DC
		Min	Max	Kv (m ³ /h)	Cv	Inrush	Holding					
M5	1.6	0.5 (7.25)	5 (72.5)	0.04	0.05	-	-	4	NBR	H226A546S0A00	F3	-
										H226A546S0A00	-	F1
										H226A547S0A00	F3	-
										H226A547S0A00	-	F1
		0.2 (2.90)	3 (43.5)					2.5		H226A545S0A00	F3	-
										H226A545S0A00	-	F1

010789B-2019-R01

Dimensions: mm (inches)

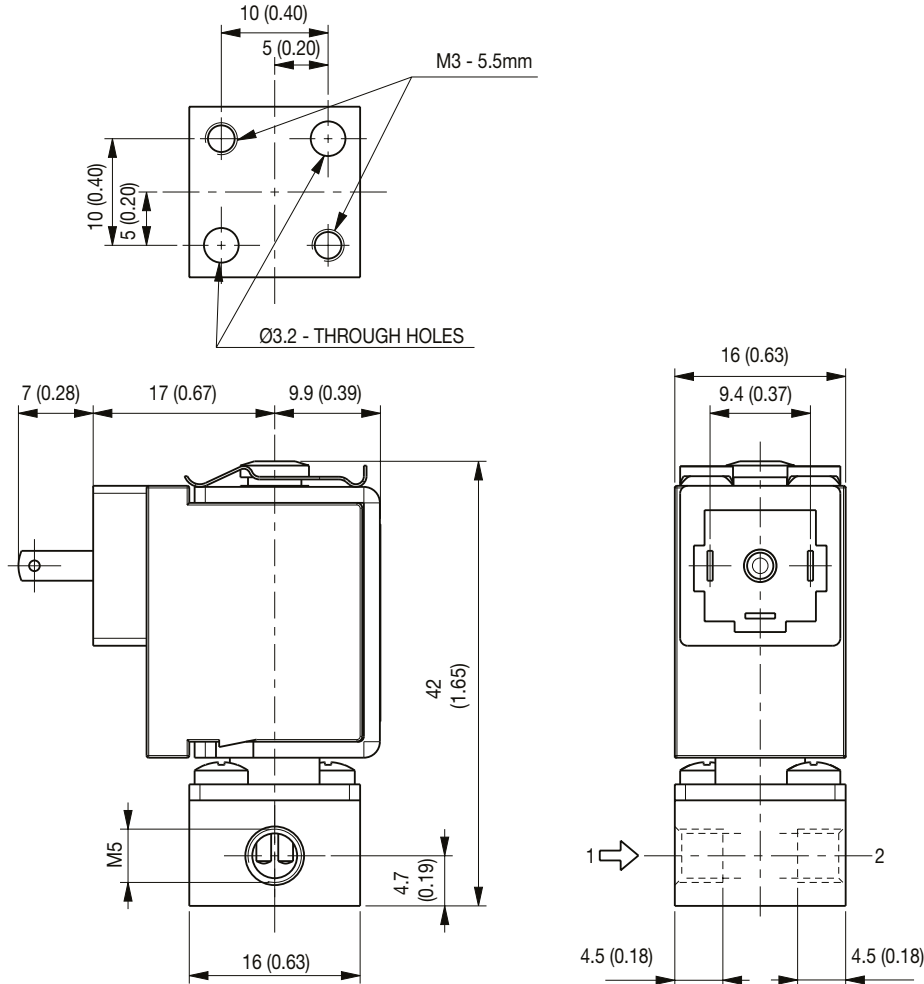

Installation

- Solenoid valve can be mounted in any position; vertical with coil upwards preferred.

NOTE:

- These micro-solenoid valves are not suitable for stagnating media subject to vaporization which deposit solid, calcareous, incrusting residues or similar.
- Seal: NBR = Nitrile butylene elastomer. Other options available on request
- It is necessary to keep the current circulating in the coil constant, so as to maintain the solenoid valve in any pre-determined position. In case the solenoid valve is energised by voltage variation, it has to be considered that the resistance of winding increases because of the continued energizing and consequently the power decreases. Therefore, it is necessary to compensate such power decrease by increasing the voltage to re-establish the initial current value.

ASCO™ MINIATURE SOLENOID VALVES

GENERAL SERVICE VALVES, 2-WAY NORMALLY CLOSED - CARTRIDGE

- The Series 226 direct acting solenoid valve can be used with both liquids and gases
- Low power versions (0.5W), and latching coil versions (power consumption close to zero) results in a decrease in OEM instrument power consumption as well as a decrease in heat transferred to the fluid media
- Small form-factor saves space in OEM instruments and are well-suited for portable and hand-held field devices
- Multiple electrical connection options and a rotatable coil create greater flexibility in OEM instrument design and serviceability
- Various connections are available so that the valve can easily be integrated into virtually any fluidic path
- Meets all relevant CE directives, and is RoHS compliant
- Typical applications include:
 - Dental Equipment
 - Gas Chromatography
 - Industrial Analyzers
 - Respiratory Devices

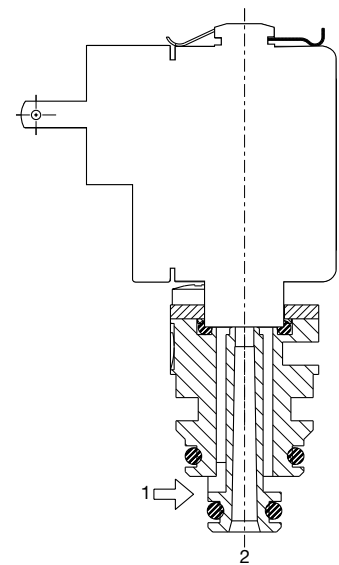
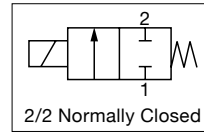

Fluids*	Temperature Range	Seal Materials*
Liquids and gases	-10°C to 100°C (14°F to 212°F)	EPDM

* Ensure that the compatibility of the materials in contact with the fluids is verified.

General Valve Information	
Body	POM
Internal components	Stainless steel
Seat	POM
Core tube	Stainless steel
Maximum allowable pressure	16 bar (232 psi)
Response Time	<10ms
Max viscosity	3°E (22 cStokes or mm ² /s)

Electrical Characteristics	
Continuous duty	ED 100%
Encapsulation material	PA (Polyamide) fiberglass reinforced
Ambient temperature	-10°C to 60°C (14°F to 140°F)
Electric connection*	DIN 46340
Electrical Enclosure Protection	IP 65 (EN 60529) with micro plug connector
Standard Voltages	12 VDC, 24 VDC (-5%/+10%)

* leaded coil on request

Specifications															
Connection	Orifice size mm (inches)	Operating Pressure bar (psi)				Flow Coefficient		Power Rating			Seals	Catalog Number		Voltage	
		Ap max.				Kv (m ³ /h)	Cv	AC (VA)		W		Valve	12V DC	24V DC	
		Ap min	Gases		Liquids			Inrush	Holding						
			AC	DC	AC										DC
-	2 (0.079)	0	-	6 (87)	-	6 (87)	0.10	0.12	-	-	4	EPDM	P226A550S0A00	F3	F1

01079GB-2019-R01

Dimensions: mm (inches)

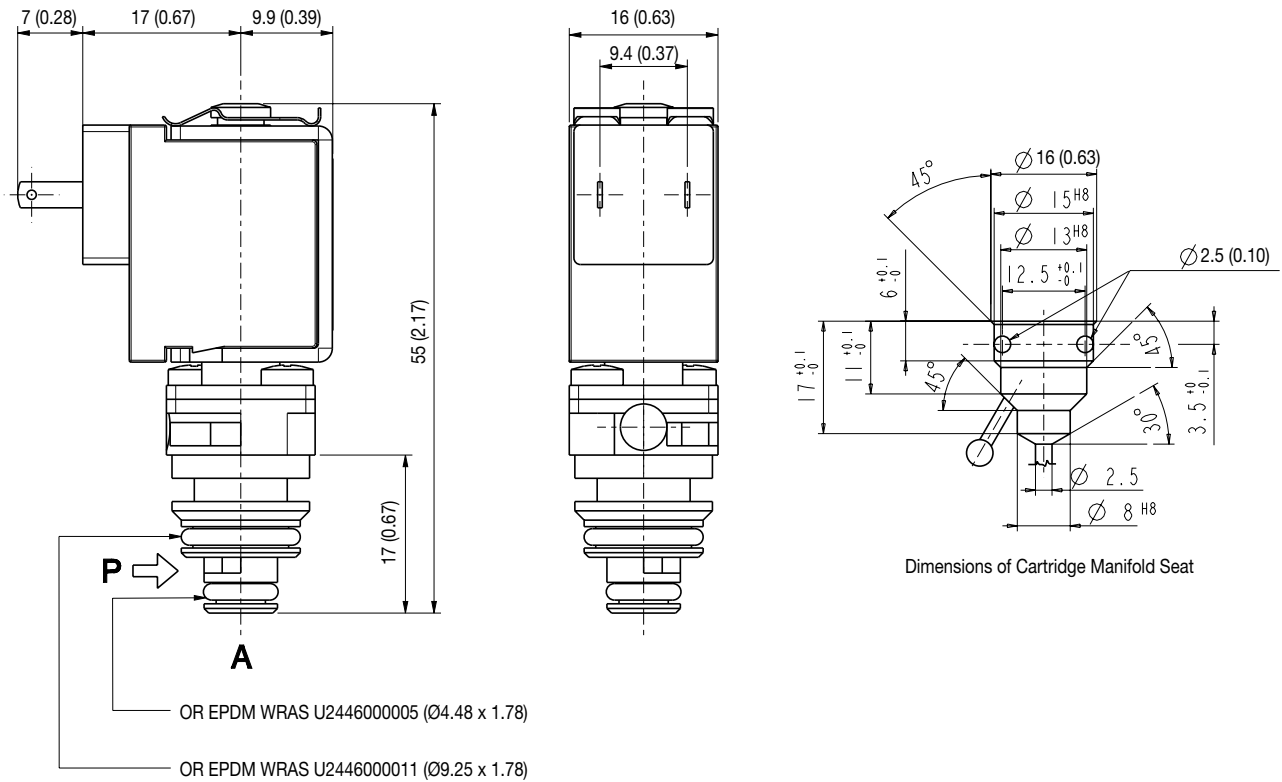

Installation

- Solenoid valve can be mounted in any position; vertical with coil upwards preferred.

NOTE:

- These micro-solenoid valves are not suitable for stagnating media subject to vaporization which deposit solid, calcareous, incrusting residues or similar.
- Sealings: EPDM = WRAS approved ethylene-propylene elastomer

ASCO™ MINIATURE SOLENOID VALVES

GENERAL SERVICE VALVES

- The 411 Series solenoid valves are designed for use with air and inert gases
- Manifold mount construction that is suitable for a wide variety of gas applications
- Compact light-weight architecture and low power consumption make them ideal for portable medical devices
- Exceptional service lifetime over 100 million cycles that increases OEM instrument reliability
- Meets all relevant CE directives, and is RoHS compliant
- Typical applications include:
 - Respiratory Therapy
 - Patient Monitoring
 - Compression Therapy (DVT)
 - Robotic Pharmacy Dispensing

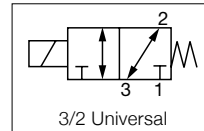
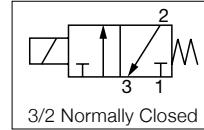
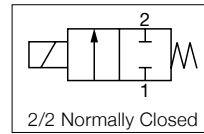

Fluids	Temperature Range	Seal Materials
Air or Inert Gas, non-lubricated ¹	-23 °C to 60 °C (-10 °F to 140 °F)	FKM, NBR, EDPM

¹ filtered at 10 µm

NOTE: Additional constructions and options are available including alternate elastomers and orifice sizes. Minimum quantities apply.

General Valve Information*	
Body	PBT, 300 Series stainless steel
Others	PBT, 400 Series stainless steel, 300 Series stainless steel
Response Time	< 10ms
Vacuum Rating	-0.9 bar (-13 psi)

* Other materials on request

Electrical Characteristics	
Standard Voltages*	5 VDC, 6 VDC, 12 VDC, 24 VDC
Power Consumption	0.65 to 2.0 W

* Other voltages on request

NOTE: The solenoid valves are designed for continuous operation within the maximum ambient temperature limits.

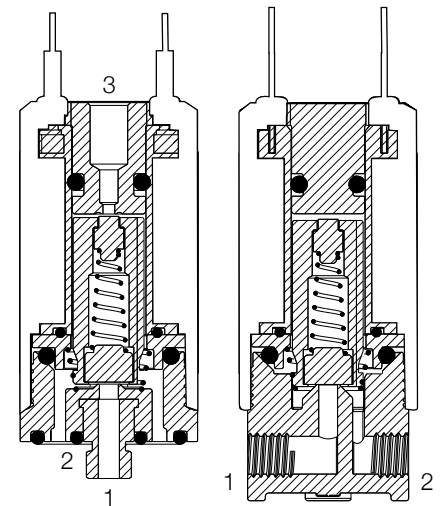

Insulation Class	Coil Insulation	Protection	Ambient Temperature Range	Electrical Connection
	°C (°F)		VA	
B	130 (266)	-	-23 to 60 (-10 to 140)	0.11in Spade, 24 AWG Lead Wire

01071GB-2019-R01

Specifications									
Orifice Size		Flow Coefficient				Operating Pressure bar (psi)		Power	Catalog Number
mm (inches)		Kv (m³/h)		Cv		min.	max.	W	
Port 1	Port 3	Port 1	Port 3	Port 1	Port 3				
2/2 NC - Normally Closed									
0.76 (0.030)	-	0.022	-	0.013	-	-0.9 (-13)	6.9 (100)	0.65	411x11xxxx
1.4 (0.055)	-	0.066	-	0.040	-	-0.9 (-13)	6.9 (100)	2.0	411x21xxxx
2.0 (0.080)	-	0.116	-	0.071	-	-0.9 (-13)	2.1 (30)	2.0	411x31xxxx
3/2 NC - Normally Closed									
0.76 (0.030)	0.63 (0.025)	0.022	0.010	0.013	0.006	-0.9 (-13)	6.9 (100)	0.65	411x12xxxx
1.4 (0.055)	1.3 (0.050)	0.066	0.055	0.040	0.033	-0.9 (-13)	6.9 (100)	2.0	411x22xxxx
2.0 (0.080)	1.3 (0.050)	0.116	0.055	0.071	0.033	-0.9 (-13)	2.1 (30)	2.0	411x32xxxx
3/2 U - Universal									
0.76 (0.030)	0.63 (0.025)	0.022	0.010	0.013	0.006	-0.9 (-13)	6.9 (100)	0.65	411x13xxHx
1.4 (0.055)	1.3 (0.050)	0.066	0.055	0.040	0.033	-0.9 (-13)	3.4 (50)	2.0	411x23xxHx
2.0 (0.080)	1.3 (0.050)	0.116	0.055	0.071	0.033	-0.9 (-13)	2.1 (30)	2.0	411x33xxHx

How to Order

411 **x** **11** **xx** **x** **x** **x**

Catalog Number 411

Mounting Style
M = Manifold, 10-32 UNF
L = Line, 10-32 UNF
K = Manifold, M5
J = Line, M5

Base Number
(see Specifications table)

Voltage
12 = 12 VDC
24 = 24 VDC
05 = 5 VDC
06 = 6 VDC

Option Suffix
O = Oxygen Service
P = Label Pressure units in kPa
S = Stainless Steel Body

Seal Material
V = FKM
E = EPDM
B = NBR

Electrical Connection
F = 0.11in Spade
H = Leaded Coil

NOTE: Oxygen Service valves available with FKM or EPDM Seals only. UL / CSA available with 300 Series Stainless Steel Body. 3-Way Universal operation only available with leaded coil electrical connection (H).

Ordering Examples:

- 411M1124FV** = 2-way normally closed manifold mount valve with 0.76mm (0.030in) orifice, 24 VDC coil rating at 0.65 Watts, .110 spade connection, FKM seals
- 411L3212HV** = 3-way normally closed line mount valve with 2.0mm (0.080in) orifice, 12 VDC coil rating at 2.0 Watts, leaded coil, FKM seals
- 411K1124HVOS** = 2-way normally closed manifold mount and M5 stud with 0.76mm (0.030in) orifice, 24 VDC coil rating at 0.65 Watts, leaded coil, FKM seals, clean for Oxygen use and Stainless Steel body

ASCO™ MINIATURE SOLENOID VALVES

GENERAL SERVICE VALVES

Dimensions: mm (inches)

2- and 3-Way Manifold Mount Solenoid

PBT Body

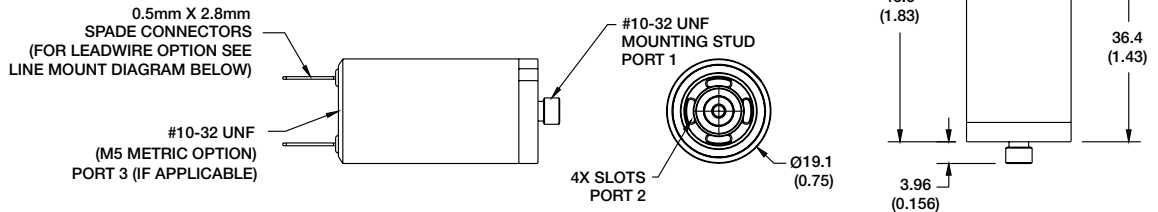

Stainless Steel Body

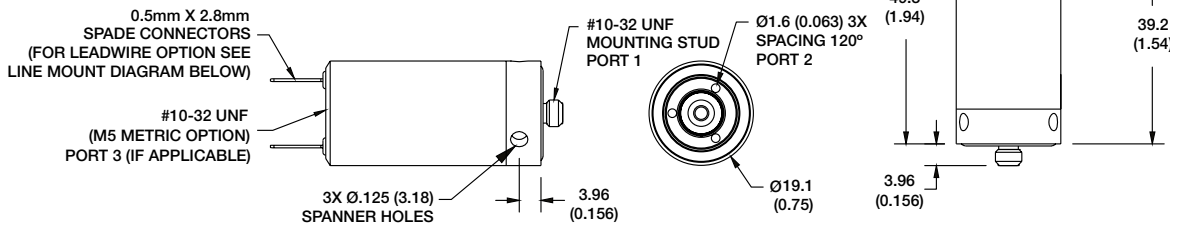

2- and 3-Way Line Mount Solenoid

PBT Body

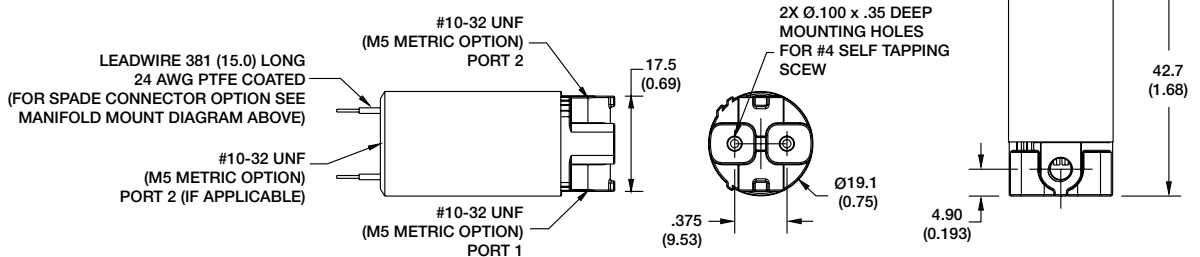

Stainless Steel Body

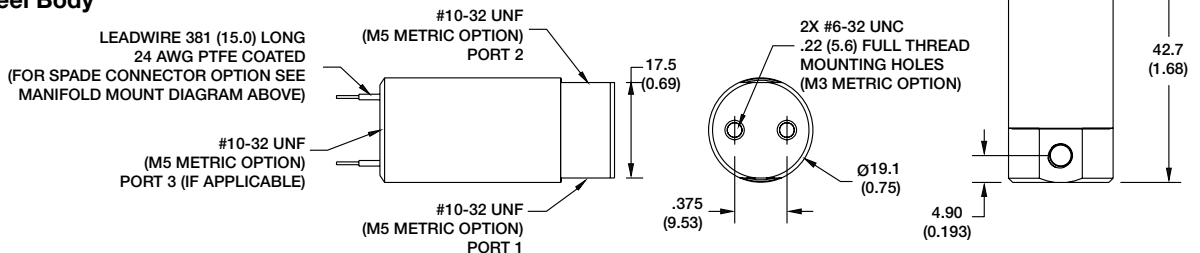

01071GB-2019-R01

ASCO™ MINIATURE SOLENOID VALVES

GENERAL SERVICE VALVES

SERIES
L256

- Direct acting solenoid valve, suitable for vacuum at port "P" (PA – PP = 1 bar)
- Suitable to shut off liquid and gaseous fluids (verify the compatibility of fluid with materials in contact), particularly suitable in the applications in sterilising autoclaves.
- Typical applications include:
 - Oil burners
 - Air compressor
 - Water steam sterilizers,
 - Gas oil burners
 - Naphta burners

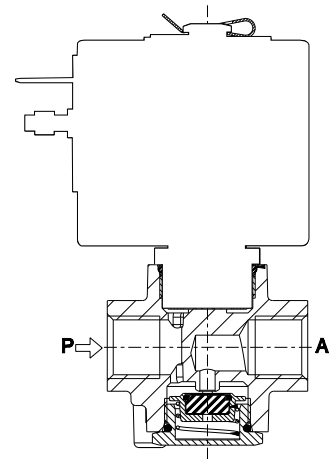
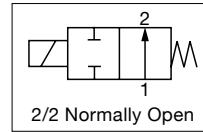

General Valve Information	
Body	Brass or chemically nickel coated (Ni-P) brass
Seals*	FKM, Stainless steel or CR70N
Internal Components	Stainless Steel
Seat	Brass or Stainless Steel
Core Tube	Stainless Steel
Shading coil	Copper
Fluids	Liquids or gases
Fluid temperature	-10°C +170°C (stainless steel) 0°C +130°C (FKM) -10°C +90°C (CR70N)
Differential pressure	see "Specifications" [1 bar = 100 kPa]
Response time	~ 20-30ms
Max. Viscosity	37 cSt (mm²/s)

* Ensure that the compatibility of the materials in contact with the fluids is verified

Electrical Characteristics			
	ZA130A	ZA10A (UL class F - for UL cl.H: ZA34 (E153691))	
Continuous duty	ED 100%	ED 100%	
Coil Insulation Class	F (140°C), on request class H (165°C) - UL	F (155°C) on request class H (180°C)	
Connector	DIN 46340 - 3 pole connector (DIN 43650)	DIN 46340 - 3 pole connector (DIN 43650)	
Encapsulation material	PET (polyethylene terephthalate) fiberglass reinforced	PPS (polyphenylsulfure) fiberglass reinforced	
Electrical Enclosure Protection	Molded IP65 (EN 60529)	IP67 (EN60529) with plug connector	
Standard Voltages *	DC	12-24 V (+10% -5%)	12-24 V (+10% -5%)
	AC	24V/50Hz - 110V/50Hz (120V/60Hz) - 230V/50Hz (+10% -15%)	24V/50Hz - 110V/50Hz (120V/60Hz) - 230V/50Hz (+10% -15%)

*Other voltages and frequencies on request

Specifications														
Pipe Connection	Orifice Size	Flow Coefficient		Operating Pressure bar			Power Rating (W)			Catalog Number		Body Material	Seat Materials	Sealing Materials
				min.	max.		AC (VA)		DC (W)	Threaded Body				
					Gases	Liquids	Inrush	Holding			Coil			
mm	Kv	Cv												
G 1/4	3	0.22	0.25	0	-	30	44	24	13	L256M02	Z130A	Brass	Stainless Steel	Stainless Steel
	3.2	0.3	0.35		12	10				L256V01			Brass	FKM
	4.5	0.45	0.52		5	4								
G 1/4	3.2	0.3	0.35	0	4	4	23	14	9	L256V12 (*)	ZA10A	Chemically nickel coated (Ni-P) brass	Stainless Steel	FKM
	4.5	0.45	0.52		2.5	2.5				L256V14 (*)			Brass	
										L256V12				
G1/8	1.6	0.08	0.09	0	25	22	23	14	9	L256N07	ZA10A	Brass	Brass	CR70N
1/4 NPT	3.2	0.3	0.35	0	12	10	44	24	13	L256V09	Z130A	Brass	Brass	FKM

(*) Only for use with steam, consider following values: max pressure 2.8 bar (max fluid temperature 130° C)

01090GB-2019-F01

Dimensions: mm (inches)

L256V01 / L256MO2

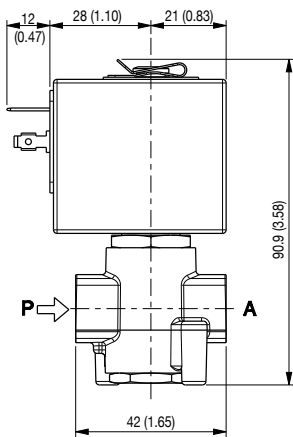
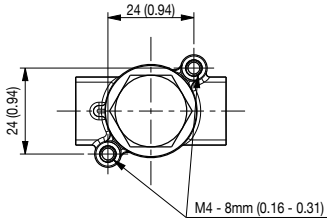

L256N07

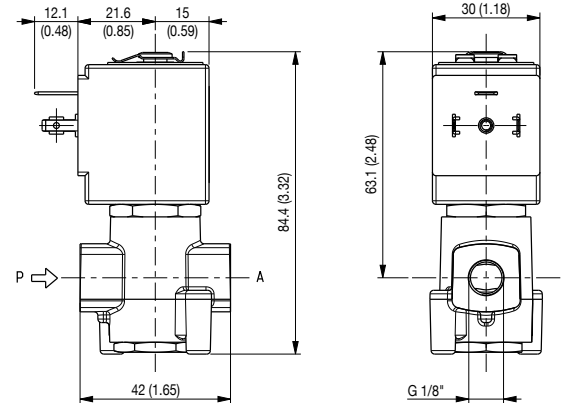
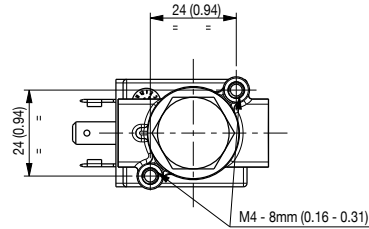

L256V09

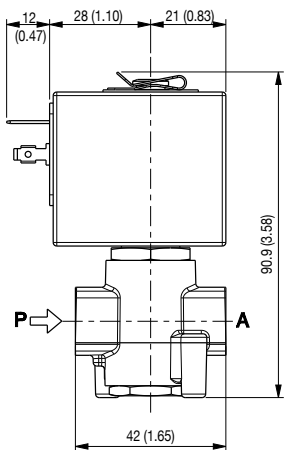
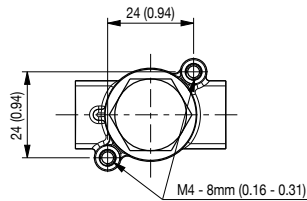

L256V12 / L256V14

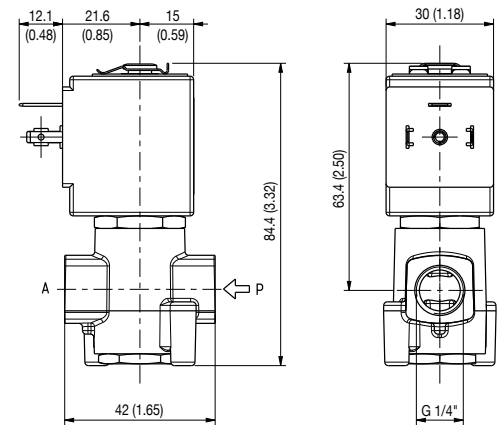
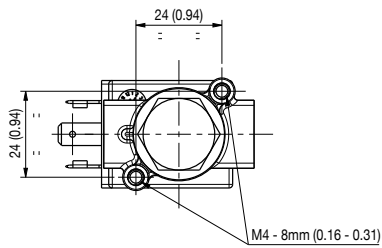

01090GB-2019-F01

Spare Part Kits

L256V01 / L256M02

Kit description	Model	Diameter	Kit P.N.	Consisting of:
Core sealing assembly kit	L256M02		G3093201	Sealing group
	L256V01	Ø 3.2	G3093101	Sealing return spring
	L256V01	Ø 4.5	G3093104	OR cap
OR guide assembly kit			GU2424000017	N°.10 OR guide assembly
OR cap kit			GU2424000155	N°.10 OR cap
Coil			Z130A	Coil

L256N07

Kit description	Kit P.N.	Consisting of:
Sealing assembly kit	G3093103	Sealing group Sealing return spring OR cap
OR guide assembly kit	GU2445000017	N°.10 OR guide assembly
OR cap kit	GU2445000155	N°.10 OR cap
Coil	ZA10A	Coil

L256V09

Kit description	Kit P.N.	Consisting of:
Core sealing assembly kit	G3093101	Sealing group Sealing return spring OR cap
OR guide assembly kit	GU2424000017	N°.10 OR guide assembly
OR cap kit	GU2424000155	N°.10 OR cap
Coil	Z130A	Coil

L256V12 / L256V14

Kit description	Kit P.N.	Consisting of:
Sealing assembly kit	G3124301	Sealing group Sealing return spring OR cap
OR guide assembly kit	GU2424000017	N°.10 OR guide assembly
OR cap kit	GU2424000155	N°.10 OR cap
Coil	ZA10A	Coil

Installation

- Solenoid valve can be mounted in any position; vertical with coil upwards preferred.

ASCO™ MINIATURE SOLENOID VALVES

GENERAL SERVICE VALVES

- The RB Series solenoid valves are designed for use with air and inert gases
- Highly customizable construction that is suitable for a wide variety of gas applications
- Compact light-weight architecture and low power consumption make them ideal for portable medical devices
- Exceptional service lifetime over 100 million cycles that increases OEM instrument reliability
- Meets all relevant CE directives, and is RoHS compliant
- Typical applications include:
 - Respiratory Therapy
 - Patient Monitoring
 - Compression Therapy (DVT)
 - Robotic Pharmacy Dispensing

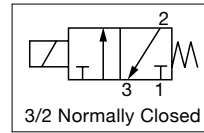
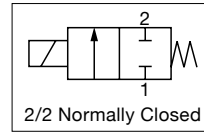

Fluids*	Temperature Range	Seal Materials*
Air or Inert Gas ¹	0 °C to 60 °C (32 °F to 140 °F)	FKM
		NBR

¹ filtered at 10µm

* Ensure that the compatibility of the materials in contact with the fluids is verified.

NOTE: Additional constructions and options are available including alternate elastomers and orifice sizes. Minimum quantities apply.

General Valve Information	
Body	PBT, brass
Others	Stainless steel
Response Time	< 10ms
Vacuum Rating	-0.9 bar (13 psi)

Electrical Characteristics	
Standard Voltages*	5 VDC, 12 VDC, 24 VDC
Power Consumption	0.5 to 2.0 W

* Other voltages on request

NOTE: The solenoid valves are designed for continuous operation within the maximum ambient temperature limits

Insulation Class	Coil Insulation	Protection	Ambient Temperature Range	Electrical Connection
	°C (°F)	VA	°C (°F)	
B	130 (266)	IP30 (EN 60529)	0 to 60 (32 to 140)	Lead wires 26 AWG or circuit board mount



2/2 NC Manifold Mount

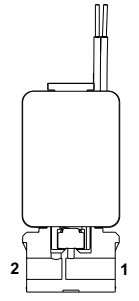

2/2 NC Line Mount

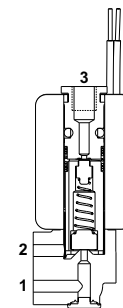

3/2 NC Pad Mount

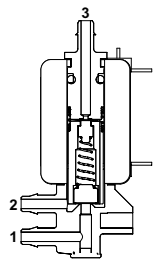

3/2 NC Push-in Hose Connection

Specifications							
Connection	Orifice Size mm (inches)	Flow Coefficient		Operating Pressure bar (psi)		Power Rating W	Catalog Number
		Kv (m ³ /h)	Cv	min.	max. air, inert gas		
2/2 NC - Normally Closed							
10-32 UNF Stud Manifold Mount, Brass (M)	0.8 (0.031)	0.018	0.011	-0.9 (-13)	3.4 (50)	0.5	RLM20xx30x
	0.8 (0.031)	0.018	0.011	-0.9 (-13)	6.9 (100)	2.0	RHM20xx30x
	1.30 (0.051)	0.066	0.030	-0.9 (-13)	1.0 (15)	0.5	RLM20xx50x
	1.30 (0.051)	0.058	0.033	-0.9 (-13)	3.4 (50)	1.0	RMM20xx50x
	1.30 (0.051)	0.058	0.033	-0.9 (-13)	6.9 (100)	2.0	RHM20xx50x
	2.00 (0.079)	0.097	0.056	-0.9 (-13)	1.0 (15)	2.0	RHM20xx80x
10-32 UNF Female Line Mount, Brass (L)	0.8 (0.031)	0.018	0.011	-0.9 (-13)	3.4 (50)	0.5	RLL20xx30x
	0.8 (0.031)	0.018	0.011	-0.9 (-13)	6.9 (100)	2.0	RHL20xx30x
	1.30 (0.051)	0.066	0.030	-0.9 (-13)	1.0 (15)	0.5	RLL20xx50x
	1.30 (0.051)	0.058	0.033	-0.9 (-13)	3.4 (50)	1.0	RML20xx50x
	1.30 (0.051)	0.058	0.033	-0.9 (-13)	6.9 (100)	2.0	RHL20xx50x
	2.00 (0.079)	0.097	0.056	-0.9 (-13)	1.0 (15)	2.0	RHL20xx80x
3.17mm (0.125in) Push-in Hose Connector PBT (B)	0.8 (0.031)	0.026	0.010	-0.9 (-13)	1.0 (15)	0.5	RLB20xx30x
	0.8 (0.031)	0.018	0.011	-0.9 (-13)	3.4 (50)	1.0	RMB20xx30x
	0.8 (0.031)	0.018	0.011	-0.9 (-13)	6.9 (100)	2.0	RHB20xx30x
	1.30 (0.051)	0.079	0.031	-0.9 (-13)	0.7 (10)	0.5	RLB20xx50x
	1.30 (0.051)	0.058	0.033	-0.9 (-13)	2.4 (35)	1.0	RMB20xx50x
	1.30 (0.051)	0.058	0.033	-0.9 (-13)	4.8 (70)	2.0	RHB20xx50x
	2.00 (0.079)	0.097	0.056	-0.9 (-13)	1.7 (25)	2.0	RHB20xx80x
Pad Mount, PBT (F)	0.8 (0.031)	0.026	0.010	-0.9 (-13)	1.0 (15)	0.5	RLF20xx30x
	0.8 (0.031)	0.018	0.011	-0.9 (-13)	3.4 (50)	1.0	RMF20xx30x
	0.8 (0.031)	0.018	0.011	-0.9 (-13)	6.9 (100)	2.0	RHF20xx30x
	1.30 (0.051)	0.079	0.031	-0.9 (-13)	0.7 (10)	0.5	RLF20xx50x
	1.30 (0.051)	0.058	0.033	-0.9 (-13)	2.4 (35)	1.0	RMF20xx50x
	1.30 (0.051)	0.058	0.033	-0.9 (-13)	4.8 (70)	2.0	RHF20xx50x
	2.00 (0.079)	0.097	0.056	-0.9 (-13)	1.7 (25)	2.0	RHF20xx80x

How to Order

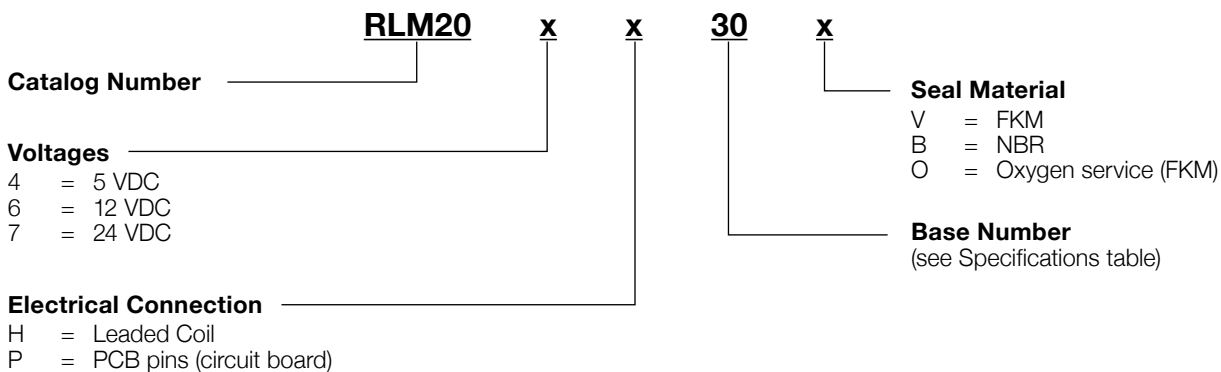

ASCO™ MINIATURE SOLENOID VALVES

GENERAL SERVICE VALVES

Specifications										
Connection	Orifice Size		Flow Coefficient				Operating Pressure bar (psi)		Power Coil W	Catalog Number
	mm (inches)		Kv (m ³ /h)		Cv		min.	max. air, inert gas		
	Port 1	Port 3	Port 1	Port 3	Port 1	Port 3				
3/2 NC - Normally Closed										
10-32 UNF Stud Manifold Mount, Brass (M)	0.8 (0.031)	1.0 (0.040)	0.018	0.031	0.011	0.018	-0.9 (-13)	3.4 (50)	0.5	RLM3xxx34x
	0.8 (0.031)	1.0 (0.040)	0.018	0.031	0.011	0.018	-0.9 (-13)	6.9 (100)	2.0	RHM3xxx34x
	1.30 (0.051)	1.3 (0.051)	0.066	0.052	0.030	0.024	-0.9 (-13)	1.0 (15)	0.5	RLM3xxx55x
	1.30 (0.051)	1.3 (0.051)	0.058	0.050	0.033	0.029	-0.9 (-13)	3.4 (50)	1.0	RMM3xxx55x
	1.30 (0.051)	1.3 (0.051)	0.058	0.050	0.033	0.029	-0.9 (-13)	6.9 (100)	2.0	RHM3xxx55x
	2.00 (0.079)	1.3 (0.051)	0.097	0.050	0.056	0.029	-0.9 (-13)	1.7 (25)	2.0	RHM3xxx85x
10-32 UNF Female Line Mount, Brass (L)	0.8 (0.031)	1.0 (0.040)	0.018	0.031	0.011	0.018	-0.9 (-13)	3.4 (50)	0.5	RLL3xxx34x
	0.8 (0.031)	1.0 (0.040)	0.018	0.031	0.011	0.018	-0.9 (-13)	6.9 (100)	2.0	RHL3xxx34x
	1.30 (0.051)	1.3 (0.051)	0.066	0.052	0.030	0.024	-0.9 (-13)	1.0 (15)	0.5	RLL3xxx55x
	1.30 (0.051)	1.3 (0.051)	0.058	0.050	0.033	0.029	-0.9 (-13)	3.4 (50)	1.0	RML3xxx55x
	1.30 (0.051)	1.3 (0.051)	0.058	0.050	0.033	0.029	-0.9 (-13)	6.9 (100)	2.0	RHL3xxx55x
	2.00 (0.079)	1.3 (0.051)	0.097	0.050	0.056	0.029	-0.9 (-13)	1.7 (25)	2.0	RHL3xxx85x
3.17mm (0.125in) Push-in Hose Connecton PBT (B)	0.8 (0.031)	1.0 (0.040)	0.026	0.033	0.010	0.013	-0.9 (-13)	1.0 (15)	0.5	RLB3xxx34x
	0.8 (0.031)	1.0 (0.040)	0.018	0.031	0.011	0.018	-0.9 (-13)	3.4 (50)	1.0	RMB3xxx34x
	0.8 (0.031)	1.0 (0.040)	0.018	0.031	0.011	0.018	-0.9 (-13)	6.9 (100)	2.0	RHB3xxx34x
	1.30 (0.051)	1.3 (0.051)	0.079	0.059	0.031	0.023	-0.9 (-13)	0.7 (10)	0.5	RLB3xxx55x
	1.30 (0.051)	1.3 (0.051)	0.058	0.050	0.033	0.029	-0.9 (-13)	2.4 (35)	1.0	RMB3xxx55x
	1.30 (0.051)	1.3 (0.051)	0.058	0.050	0.033	0.029	-0.9 (-13)	4.8 (70)	2.0	RHB3xxx55x
	2.00 (0.079)	1.3 (0.051)	0.097	0.050	0.056	0.029	-0.9 (-13)	1.7 (25)	2.0	RHB3xxx85x
Pad Mount, PBT (F)	0.8 (0.031)	1.0 (0.040)	0.026	0.033	0.010	0.013	-0.9 (-13)	1.0 (15)	0.5	RLF3xxx34x
	0.8 (0.031)	1.0 (0.040)	0.018	0.031	0.011	0.018	-0.9 (-13)	3.4 (50)	1.0	RMF3xxx34x
	0.8 (0.031)	1.0 (0.040)	0.018	0.031	0.011	0.018	-0.9 (-13)	6.9 (100)	2.0	RHF3xxx34x
	1.30 (0.051)	1.3 (0.051)	0.079	0.059	0.031	0.023	-0.9 (-13)	0.7 (10)	0.5	RLF3xxx55x
	1.30 (0.051)	1.3 (0.051)	0.058	0.050	0.033	0.029	-0.9 (-13)	2.4 (35)	1.0	RMF3xxx55x
	1.30 (0.051)	1.3 (0.051)	0.058	0.050	0.033	0.029	-0.9 (-13)	4.8 (70)	2.0	RHF3xxx55x
	2.00 (0.079)	1.3 (0.051)	0.097	0.050	0.056	0.029	-0.9 (-13)	1.7 (25)	2.0	RHF3xxx85x

How to Order

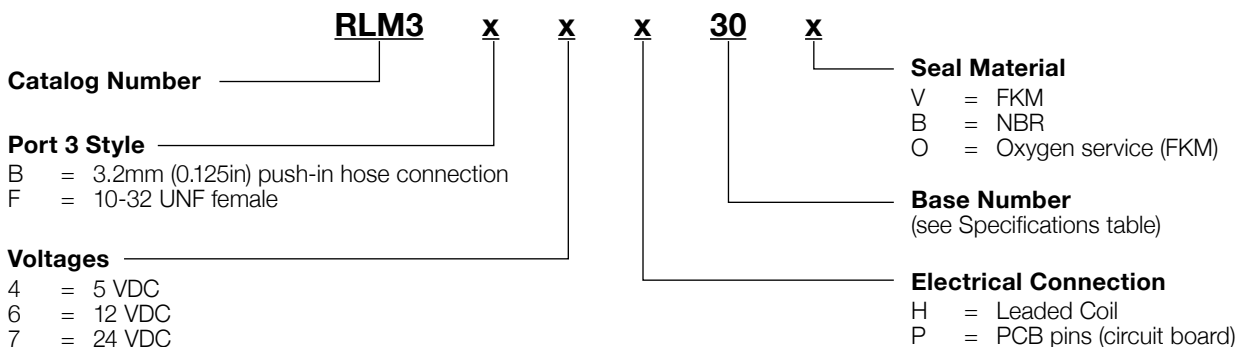

Options

- Other seal materials available on request
- Other voltages and electrical connections available
- Oxygen service
- Other pipe connections available on request

Installation

- The solenoid valves can be mounted in any position without affecting operation
- Line Mount solenoid valves have 2 mounting holes in body

01045GB-2019-F01

Dimensions: mm (inches)

2- and 3-Way Pad Mount Solenoid Valve

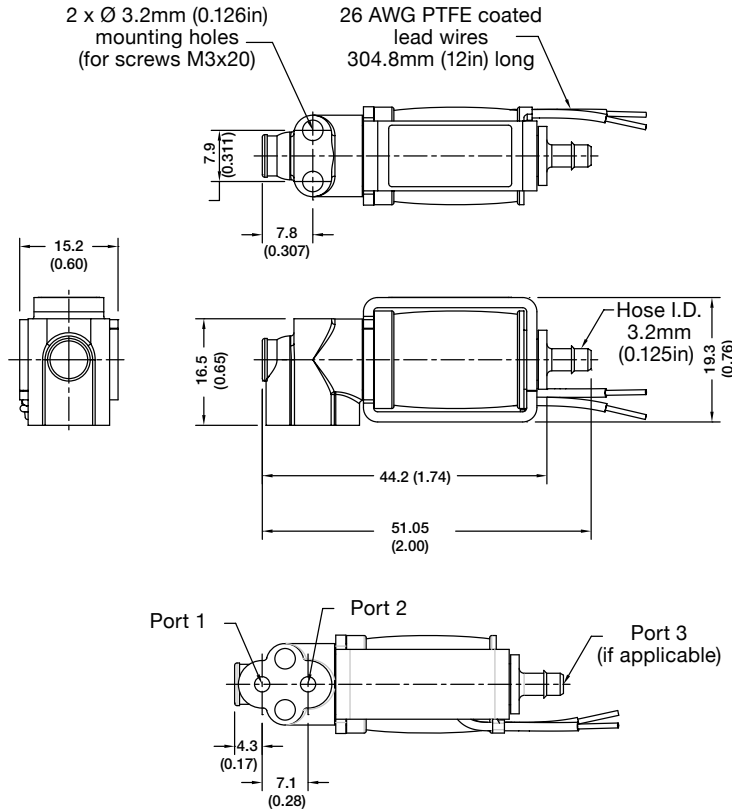

2- and 3-Way Solenoid Valve with Push-in Hose Connection

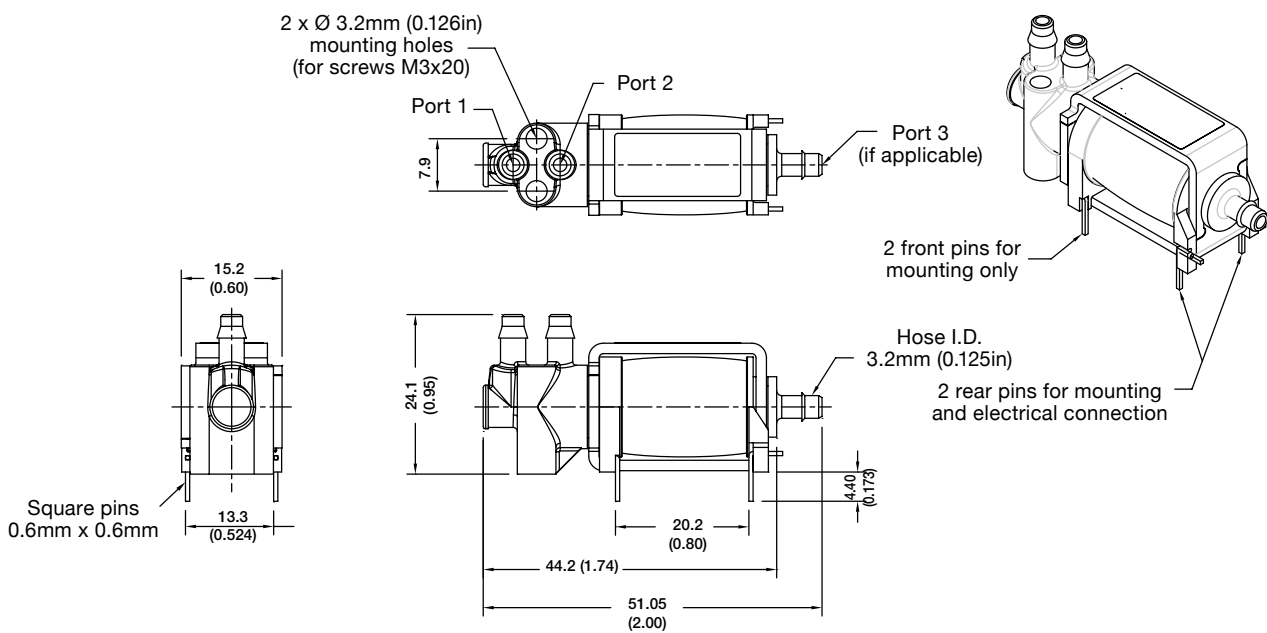

01045GB-2019-R01

ASCO™ MINIATURE SOLENOID VALVES

GENERAL SERVICE VALVES

Dimensions: mm (inches)

2- and 3-Way Line Mount Solenoid Valve

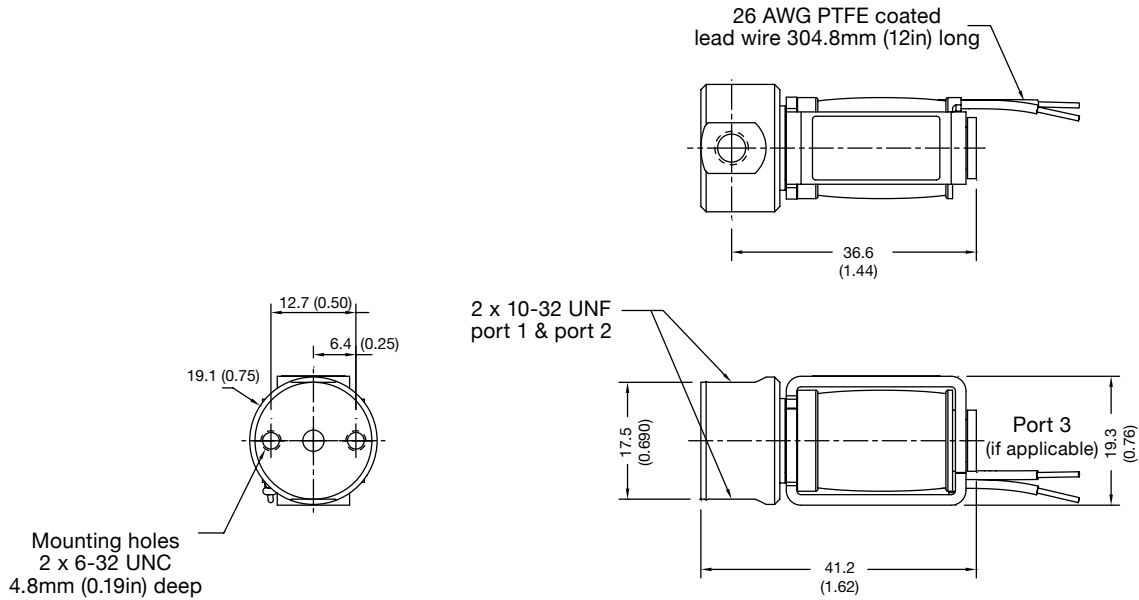

2- and 3-Way Manifold Mount Solenoid Valve

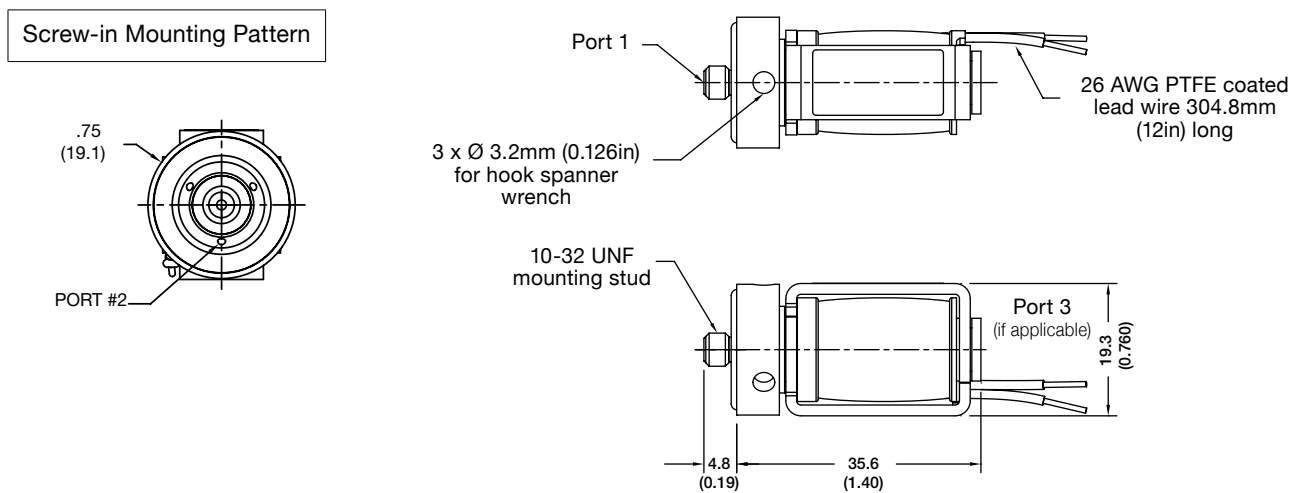

01045GB-2019-F01

ASCO™ MINIATURE SOLENOID VALVES

GENERAL SERVICE VALVES

- The S Series solenoid valves are designed for use with air and inert gases
- Compact light-weight architecture and low power consumption make them ideal for portable medical devices
- Larger orifice sizes and vacuum capability make these valves extremely versatile across multiple disciplines
- Available in a variety of different porting configurations for manifold and in-line mounting
- Meets all relevant CE directives, and is RoHS compliant
- Typical applications include:
 - Respiratory Therapy
 - Anesthesia Delivery
 - Dental
 - Industrial Gas Analyzers

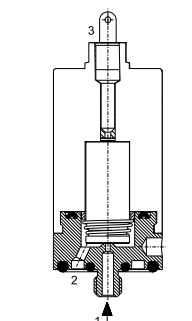
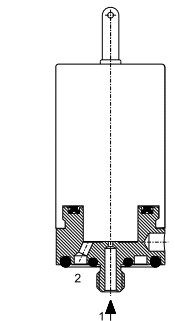
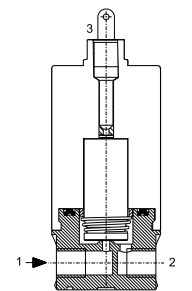
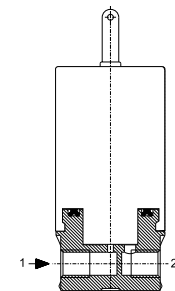
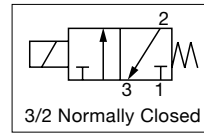
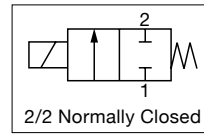

Fluids*	Temperature Range	Seal Materials*
Air or Inert Gases ¹	-23 °C to 66 °C (-10 °F to 150 °F)	FKM (fluoroelastomer), (EPDM on request)

¹ Filtered at 10µm

* Ensure that the compatibility of the materials in contact with the fluids is verified.

General Valve Information	
Body	Stainless steel
Others	Stainless steel
Response Time	< 10ms
Vacuum Rating	-1 bar (-14.5 psi)

Electrical Characteristics	
Standard Voltages	12 VDC, 24 VDC
Power Consumption	0.65, 2.0 W

Insulation Class	Coil Insulation	Protection	Power Ratings				Ambient Temperature Range	Electrical Connection	Type ¹
			Inrush	Holding	Hot/ Cold				
	°C (°F)	VA	VA	VA	W	W	°C (°F)		
B	-	IP40 (EN 60529)	-	-	-	1.5/1.5	-23 to 66 (-10 to 150)	Spade plug or lead wires 20 AWG, length 300mm (11.8in)	01

¹ Refer to the dimensional drawings on the following page

Specifications											
Connection	Orifice Size		Flow Coefficient		Operating Pressure, bar (psi)			Power Rating	Catalog Number		
	mm (inches)		Kv (m ³ /h)	Cv	min.	max.			W	Line Mount Body	
						air and gases					
2/2 NC - Normally Closed											
M5	0.75 (0.03)		0.025	0.016	-0.9 (-13)	-	7 (102)	-	1.5	HSM2Lxx00V	HSM2Mxx00V
	1 (0.04)		0.041	0.027	-0.9 (-13)	-	7 (102)	-	1.5	HSM2Lxx10V	HSM2Mxx10V
	2 (0.08)		0.085	0.057	-0.9 (-13)	-	3.5 (51)	-	1.5	HSM2Lxx50V	HSM2Mxx50V
3/2 NC - Normally Closed											
M5	Port 1	Port 2									
	0.75 (0.03)	1 (0.04)	0.025	0.016	-0.9 (-13)	-	7 (102)	-	1.5	HSM3Lxx00V	HSM3Mxx00V
	1 (0.04)	1 (0.04)	0.041	0.027	-0.9 (-13)	-	7 (102)	-	1.5	HSM3Lxx10V	HSM3Mxx10V
	2 (0.08)	1 (0.04)	0.085	0.057	-0.9 (-13)	-	3.5 (51)	-	1.5	HSM3Lxx50V	HSM3Mxx50V

01041GB-2019-R01

How to Order

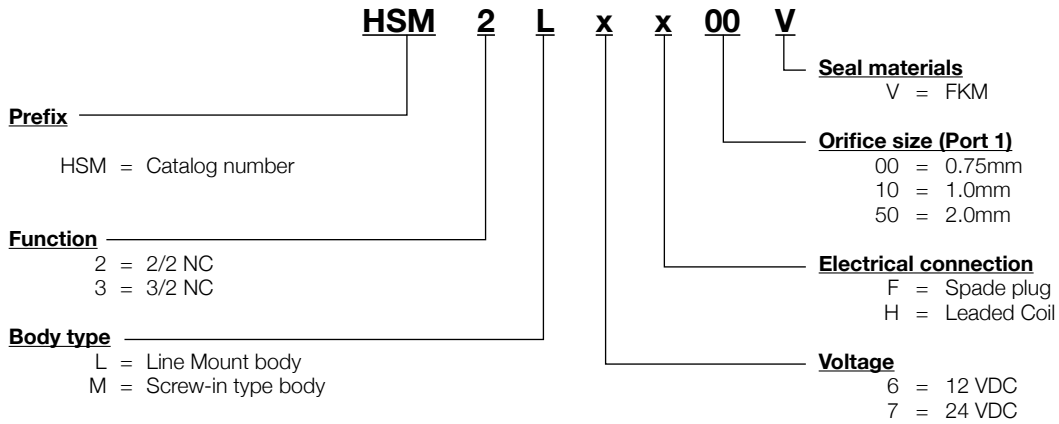

Dimensions: mm (inches)

HSM2Lxx00V/HSM2Lxx10V/HSM2Lxx50V
HSM2Mxx00V/HSM2Mxx10V/HSM2Mxx50V

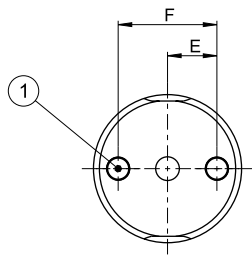

- ① 2 mounting holes $\varnothing M3 \times 0.5$
- ② Mounting with hook spanner wrench DIN 1810B

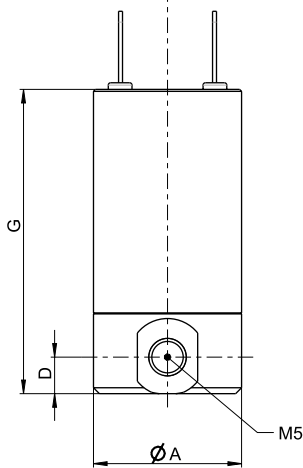

- ① 2 mounting holes $\varnothing M3 \times 0.5$
- ② Mounting with hook spanner wrench DIN 1810B

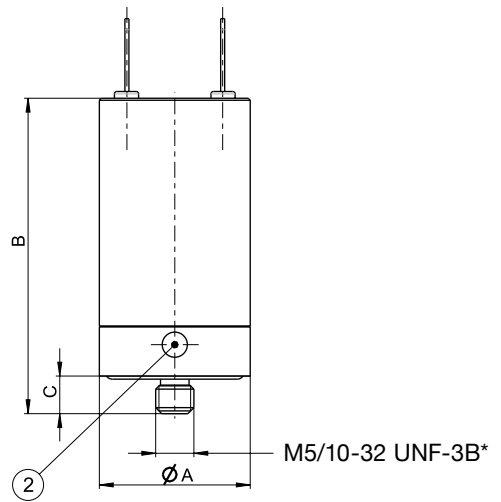

* Supplied with 10-32 UNF-3B male thread compatible with M5 female counter-thread

Screw-in Mounting Pattern

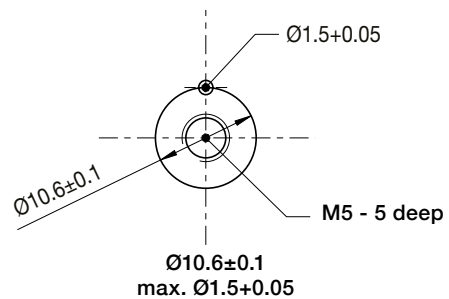

Connection Type	Catalog Number	A	B	C	D	E	F	G
Line Mount body	HSM2Lxx00V/HSM2Lxx10V/HSM2Lxx50V	19.05 (0.75)	-	-	4.7 (0.18)	6.35 (0.25)	12.7 (0.50)	39.11 (1.54)
Screw-in type body	HSM2Mxx00V/HSM2Mxx10V/HSM2Mxx50V	19.05 (0.75)	39.62 (1.56)	4.8 (0.19)	-	-	-	-

01041GB-2019-R01

ASCO™ MINIATURE SOLENOID VALVES

GENERAL SERVICE VALVES

Dimensions: mm (inches)

HSM3Lxx00V/HSM3Lxx10V/HSM3Lxx50V
HSM3Mxx00V/HSM3Mxx10V/HSM3Mxx50V

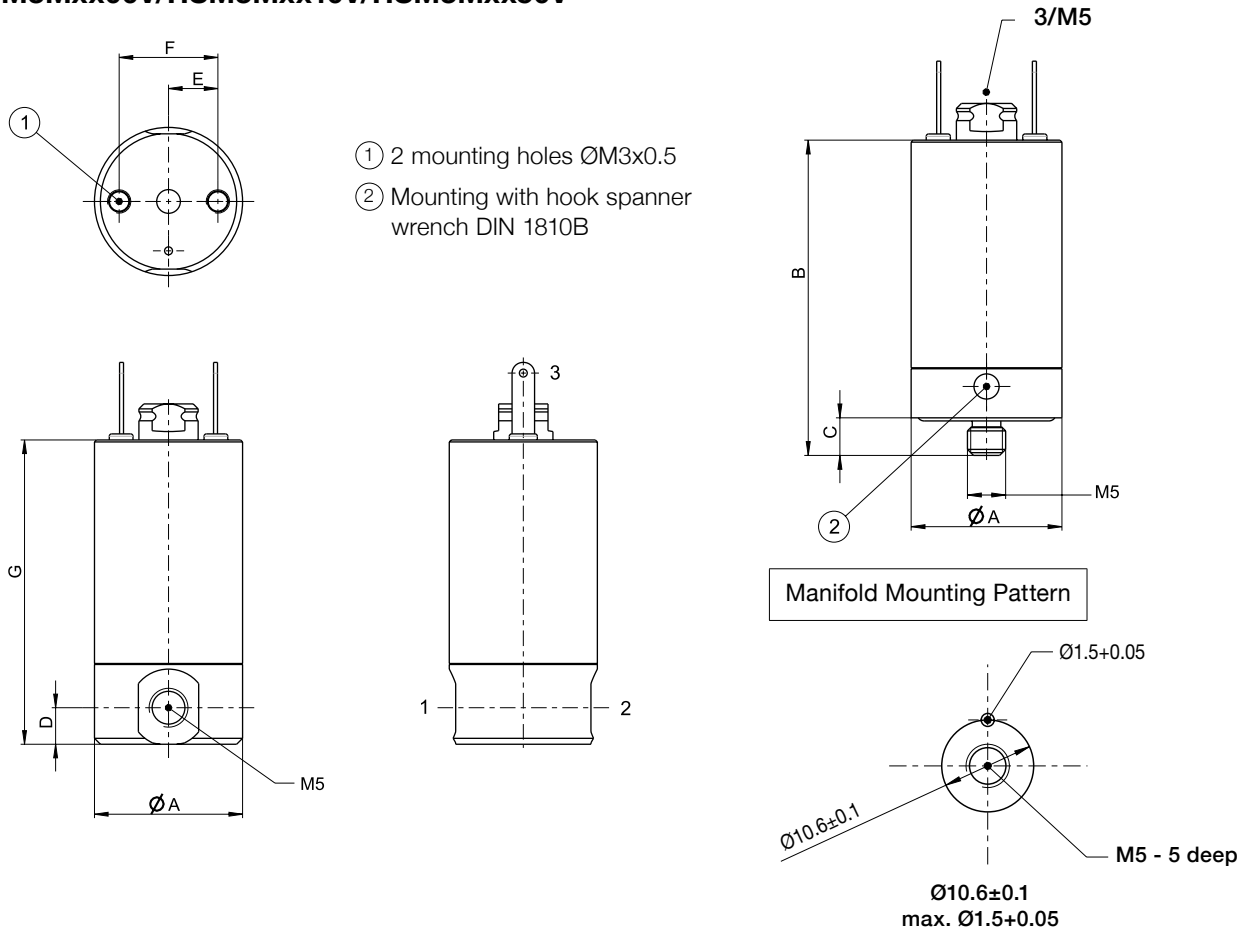

Connection Type	Catalog Number	A	B	C	D	E	F	G
Line Mount body	HSM3Lxx00V/HSM3Lxx10V/HSM3Lxx50V	19.05 (0.75)	-	-	4.7 (0.18)	6.35 (0.25)	12.7 (0.50)	39.11 (1.54)
Screw-in type body	HSM3Mxx00V/HSM3Mxx10V/HSM3Mxx50V	19.05 (0.75)	39.62 (1.56)	4.8 (0.19)	-	-	-	-

Options

- EPDM seals available on request
- Oxygen service
- Other pipe connections available on request (10-32 UNF-3B)

Installation

- The solenoid valves can be mounted in any position without affecting operation
- Line Mount solenoid valves have 2 mounting holes in body

01041GB-2019-R01

ASCO™ MINIATURE SOLENOID VALVES

FLAPPER PROPORTIONAL FLUID ISOLATION VALVES

- Flapper proportional valves are designed to proportionally control the flow of neutral and aggressive liquids and gases by varying the electrical input signal to the coil
- Special Flapper mechanism results in no pumping or sticking effects
- Reduced heat transfer between control mechanism and fluid make them ideal for use with heat-sensitive reagents and biological samples
- Hysteresis (< 20%), excellent repeatability (< 5%), and high sensitivity (< 1%) make these valves ideal for high precision flow control of liquids
- Excellent self-draining capability and easy-to-flush internal cavity
- Valves do not require a minimum operating pressure
- Meets all relevant CE directives, and is RoHS compliant
- Typical Applications include:
 - Chromatography
 - DNA Sequencing
 - In-vitro Diagnostics
 - Industrial Liquid Analyzers

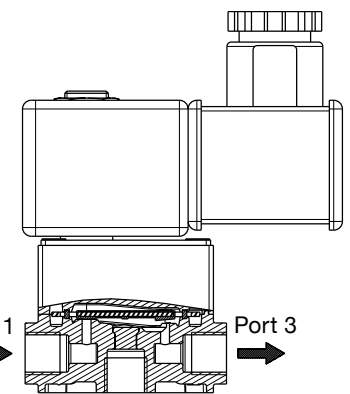
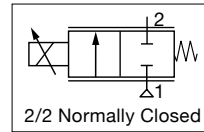

Fluids*	Temperature Range	Seal Materials*
Liquids or Gases ¹	5 °C to 50 °C (41 °F to 122 °F)	FKM/FFKM/EPDM

¹ Filtration: 50µm
* Ensure that the compatibility of the materials in contact with the fluids is verified

General Valve Information	
Body	PEEK
Others	Stainless Steel
Response Time	< 20ms
Internal Volume	0.48ml
Max. Viscosity	20 cSt (mm ² /s)

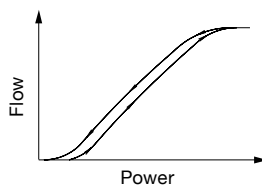

Electrical Characteristics	
Coil Insulation Class	F
Connector	Lead Wires 24 AWG; L = 500mm (19.685in)
Electrical Safety	IEC 335
Electrical Enclosure Protection	IP65 (EN 60529)
Standard Voltages	12 VDC, 24 VDC (-5%/+10%)
Voltage Regulation	0-12 VDC, 0-24 VDC Pulse-width Modulation (> 1000Hz)
Flow Regulation Characteristics	Hysteresis typ. 20%; Repeatability typ. 5%; Sensitivity typ.1%

Voltage	Max. Operating Current	Power Ratings			Ambient Temperature Range
		Inrush	Holding	Hot/Cold	
V	mA	VA	VA	W	°C (°F)
12	0	-	-	-	5 to 50 (41 to 122)
	750				
24	0	-	-	-	
	375				

Specifications							
Connection	Orifice Size mm (inches)	Flow Coefficient		Operating Pressure, bar (psi)		Power Rating (W)	Catalog Number Body PEEK
		Kv (m3/h)	Cv	min.	max. gases, liquids		
G1/8	2 (0.079)	0.069	0.080	0	4.5 (65)	9	G068A317xxx10xx
	3 (0.118)	0.123	0.142	0	2.0 (29)	9	G068A318xxx10xx
Pad Mounting ¹	2 (0.079)	0.069	0.080	0	4.5 (65)	9	R068A317xxx10xx
	3 (0.118)	0.123	0.142	0	2.0 (29)	9	R068A318xxx10xx

¹ 4 hexagon socket screws M3 x 8mm (0.315), stainless steel, ISO 4762 (supplied)

01061GB-2019-R01

How to Order

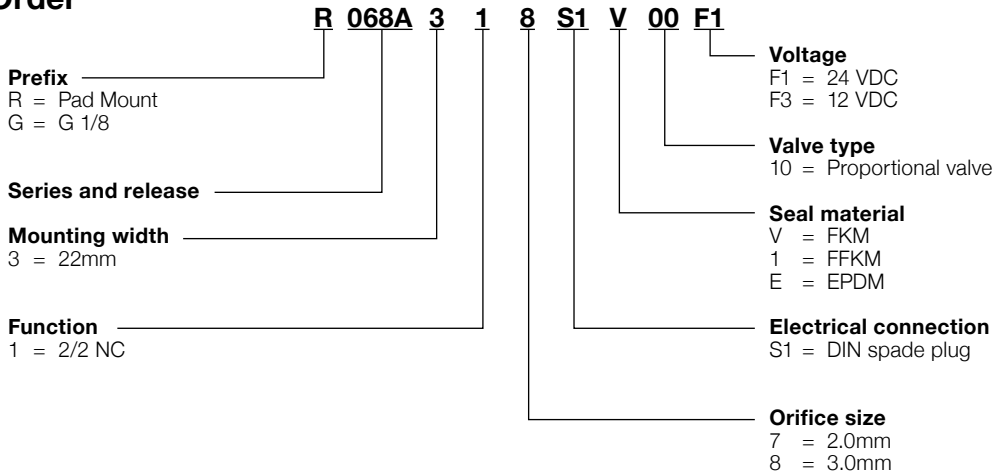

Dimensions: mm (inches)

G 1/8

Pad-mounting Body

Subbase Mounting Pattern

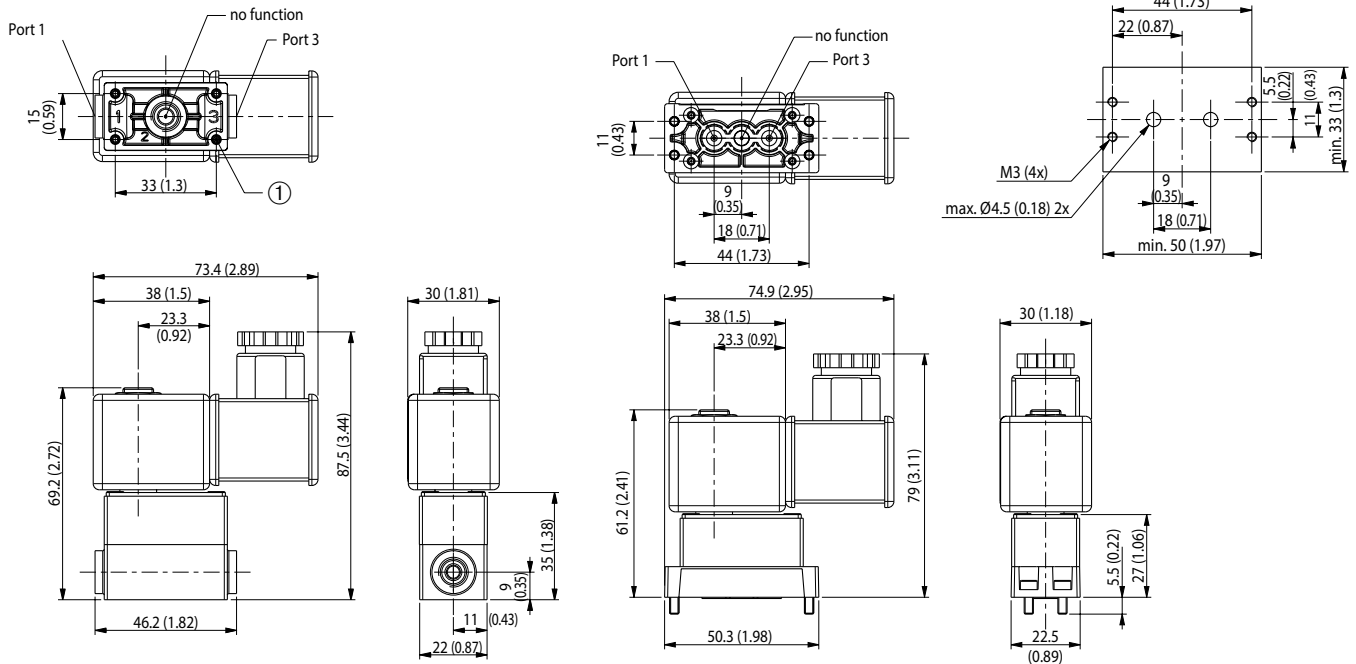

① 4 mounting holes, max. depth 7mm (0.276in), for self-tapping screw (type EJOT PT, K30)

Options

- Digital control module Control^D for DIN EN 50022 rail mounting
 - Used as a current regulator in open loop applications
 - Used with an external sensor for closed-loop applications
- Other voltages and leaded coil on request
- Subbases available on request

Installation

- The solenoid valves can be mounted in any position without affecting operation
- Pad-mounting solenoid valve supplied with seal
- Pipe connections 1/8 have standard thread according to ISO 228/1

ASCO™ MINIATURE SOLENOID VALVES

PROPORTIONAL VALVES, PRECIFLOW 12.7 mm

- Preciflow solenoid valves are designed to proportionally control the flow of air and inert gases by varying the electrical input signal to the coil
- Low hysteresis (typ. < 5%), excellent repeatability (typ. < 1%), and high sensitivity (typ. < 0.1%) make these valves ideal for high precision flow control
- Compact frictionless architecture saves valuable space in analytical and medical instrumentation
- Valves do not require a minimum operating pressure, and are well-suited for vacuum operation
- Power consumption as low as 1 W to meet the most stringent instrument power requirements
- Meets all relevant CE directives, and is RoHS compliant
- Typical applications include:
 - Gas Chromatography
 - Mass Flow Controllers
 - Dental Equipment
 - Blood Pressure Monitoring

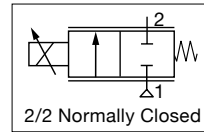

Fluids*	Temperature Range	Seal Materials*
Air, Oxygen, Inert Gas ¹	0 °C to 55 °C (32 °F to 131 °F)	FKM/FFKM

* Ensure that the compatibility of the materials in contact with the fluids is verified.
¹ Filtration: 5µm

General Valve Information	
Body	Brass
Others	Stainless Steel

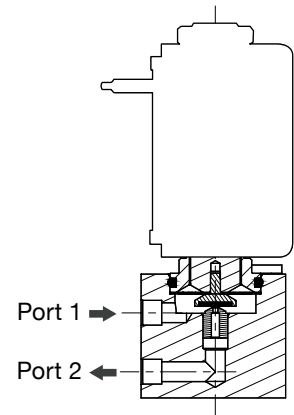
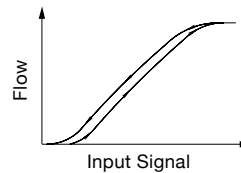

Electrical Characteristics	
Coil Insulation Class	F
Connector	Lead Wires 24 AWG; L = 500mm (19.7in)
Electrical Safety	IEC 335
Electrical Enclosure Protection	IP50
Standard Voltages	6 VDC, 12 VDC, 24 VDC
Input Signal	0-6 VDC, 0-12 VDC, 0-24 VDC Pulse-width Modulation (> 1000Hz), Current control recommended
Flow Regulation Characteristics	Hysteresis typ. 5%; Repeatability typ. 1%; Sensitivity typ. 0.1%

Voltage	Max. Operating Current	Power Ratings			Ambient Temperature Ranges	
		Inrush	Holding	Hot/Cold		
V	mA	VA	VA	W	W	°C (°F)
6	170	-	-	-	1	0 to 55 (32 to 131)
	420				2.5	
12	85				1	
	210				2.5	
24	45				1	
	110				2.5	

Specifications						
Orifice Size	Flow Coefficient		Operating Pressure bar (psi)		Power Rating	Catalog Number
	mm (inches)	Kv (m3/h)	Cv	min.		
0.045 (0.0018)	0.00006	0.00007	-0.9 (-13)	10 (145)	1	R202A540L0xxxxx
0.07 (0.0023)	0.00012	0.00014	-0.9 (-13)	10 (145)	1	R202A541L0xxxxx
0.1 (0.0040)	0.0003	0.00035	-0.9 (-13)	10 (145)	1	R202A542L0xxxxx
0.2 (0.0079)	0.0012	0.0014	-0.9 (-13)	10 (145)	1	R202A543L0xxxxx
0.4 (0.0157)	0.0048	0.0055	-0.9 (-13)	10 (145)	2.5	R202A544L0xxxxx
0.6 (0.0236)	0.0096	0.0111	-0.9 (-13)	10 (145)	2.5	R202A545L0xxxxx
0.8 (0.0315)	0.018	0.0208	-0.9 (-13)	10 (145)	2.5	R202A546L0xxxxx

* Inlet or outlet filter available on request

01062GB-2019-R01

How to Order

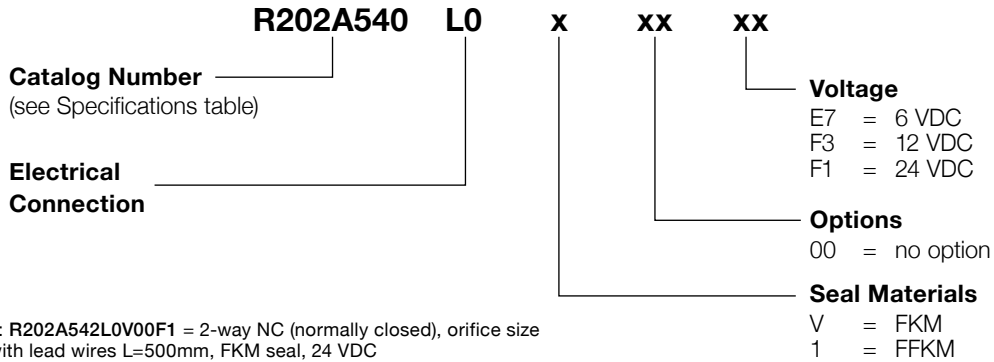

Ordering Example: R202A542L0V00F1 = 2-way NC (normally closed), orifice size 0.1mm (0.004in), with lead wires L=500mm, FKM seal, 24 VDC

Dimensions: mm (inches)

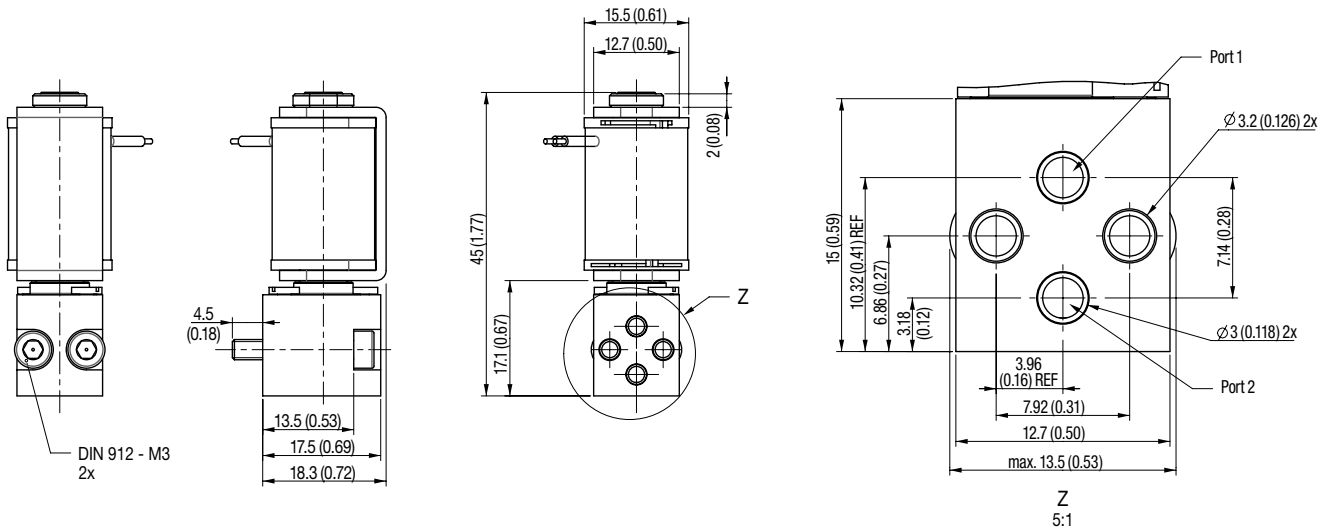

Mounting Pattern

Mounting Face (Proposal)

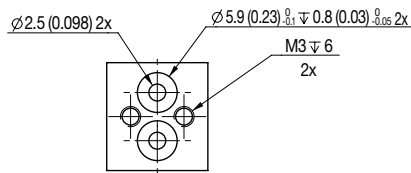
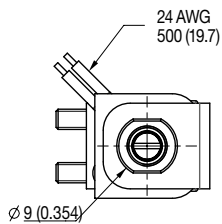

Sealing (optional)

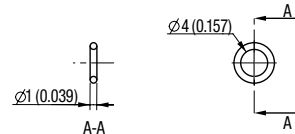

Options

- Digital control module Control^D for DIN EN 50022 rail mounting (for more information see specifications on page 185)
- Other materials and voltages available on request
- Sealing FKM: 514684-001, FFKM: 514684-002 (minimum order quantity required)
- Subbase with M5 connections and O-ring seals available:
 - 517973-001 --> Subbase with FKM O-rings
 - 517973-002 --> Subbase with FFKM O-Rings

Installation

- The solenoid valves can be mounted in any position without affecting operation
- Manifold and O-Rings not included

ASCO™ MINIATURE SOLENOID VALVES

PROPORTIONAL VALVES, PRECIFLOW 15 mm

- Preciflow solenoid valves are designed to proportionally control the flow of air and inert gases by varying the electrical input signal to the coil
- Low hysteresis (typ. < 3%), excellent repeatability (typ. < 1%), and high sensitivity (typ. < 1%) make these valves ideal for high precision flow control
- Compact frictionless architecture saves valuable space in analytical and medical instrumentation
- Valves do not require a minimum operating pressure, and are well-suited for vacuum operation
- Power consumption as low as 1 W to meet the most stringent instrument power requirements
- Meets all relevant CE directives, and is RoHS compliant
- Typical applications include:
 - Respiratory Therapy
 - Gas Chromatography
 - Blood Pressure Monitoring
 - Anesthesia Delivery

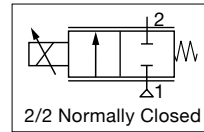

Fluids*	Temperature Range	Seal Materials*
Air, Inert Gas ¹	0 °C to 50 °C (32 °F to 122 °F)	FKM

* Ensure that the compatibility of the materials in contact with the fluids is verified.
¹ Filtration - M5 or pad mount version: 5µm - 1/8 : 50µm

General Valve Information	
Body	Brass or PVDF
Others	Brass, Stainless Steel

Electrical Characteristics	
Coil Insulation Class	F
Connector	Spade plug; cable Ø4-6mm (0.157 - 0.236in), Ø6-8mm (0.236 - 0.315in), Ø6-10mm (0.236 - 0.394in)
Connector Specification	DIN 43650, 9.4mm (0.370in), industry standard C (type 01) DIN 43650, 11mm (0.433in), industry standard B (type 02) ISO 4400/EN 175301-803, form A (type 03)
Electrical Safety	IEC 335
Electrical Enclosure Protection	Molded IP65 (EN 60529)
Standard Voltages ²	12 VDC, 24 VDC
Voltage Regulation	0-12 VDC, 0-24 VDC; Pulse-width Modulation (1000Hz)
Flow Regulation Characteristics	Hysteresis typ. < 3%; Repeatability typ. < 1%; Sensitivity typ. < 1%

² Other voltages on request

Voltage	Max. Operating Current	Power Ratings				Ambient Temperature Ranges	Type ³
		Inrush	Holding		Hot/Cold		
V	mA	VA	VA	W	W	°C (°F)	
12	85	-	-	-	1	0 to 50 (32 to 122)	01
	340				4		02
	400				5		03
24	40	-	-	-	1	0 to 50 (32 to 122)	01
	170				4		02
	230				5		03
	380				9		

³ Refer to the dimensional drawings on the following page

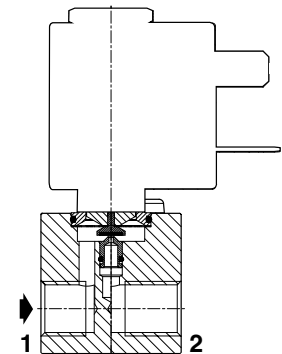
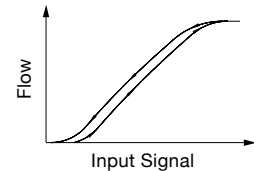

01029GB-2020-R01

Specifications									
Connection	Orifice Size	Flow Coefficient		Operating Pressure bar (psi)		Power Rating	Catalog Number		
				min.	max.		Threaded Body		ISO 15218 (CNOMO, size 15) Interface
							air, inert gas	W	
M5 or Pad Mount	0.1 (0.0040)	0.0003	0.00035	-0.9 (-13)	10 (145)	1	SCG202A500	-	SCS202A505
	0.2 (0.0079)	0.0012	0.0014			1	-	SCG202A501	SCS202A506
	0.4 (0.0157)	0.0048	0.0055			4	-	SCG202A502	SCS202A507
	0.6 (0.0236)	0.0096	0.0111			4	-	SCG202A503	SCS202A508
	0.8 (0.0315)	0.018	0.021			4	-	SCG202A504	SCS202A509
G1/8	0.8 (0.0315)	0.018	0.021	-0.9 (-13)	10 (145)	5	SCG202A510	-	-
	1.2 (0.0472)	0.041	0.047			5	SCG202A511	-	-
	1.6 (0.0630)	0.071	0.082		8 (116)	5	SCG202A512	-	-
	2.0 (0.0787)	0.096	0.111		6 (87)	5W (12V) / 9W (24V)	SCG202A513	-	-

How to Order

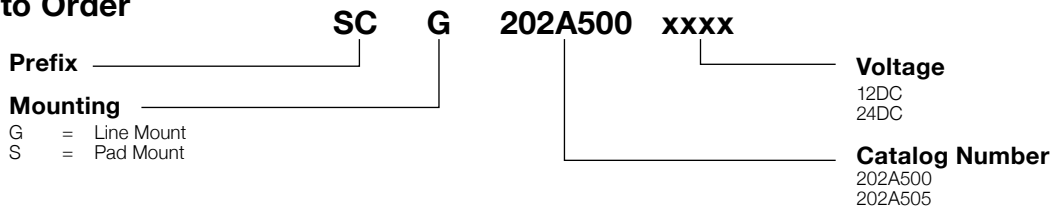

Options

- Digital control module ControlD for DIN EN 50022 rail mounting (for more information see specifications on page 185)
- Electronic control units for proportional control
- Other materials, connections, and coils available on request
- Plug with visual indication and peak voltage suppression or with cable length of 2m (78.7in)

Installation

- The valves can be mounted in any position without affecting operation
- Pipe connection identifier is: G = G (ISO 228/1)

ASCO™ MINIATURE SOLENOID VALVES

PROPORTIONAL VALVES, PRECIFLOW 15 mm

Dimensions: mm (inches)

Type 01

Prefix "SC" solenoid, epoxy molded
IEC 335/DIN 43650, 9.4mm (0.37in)
IP65



SCG202A500

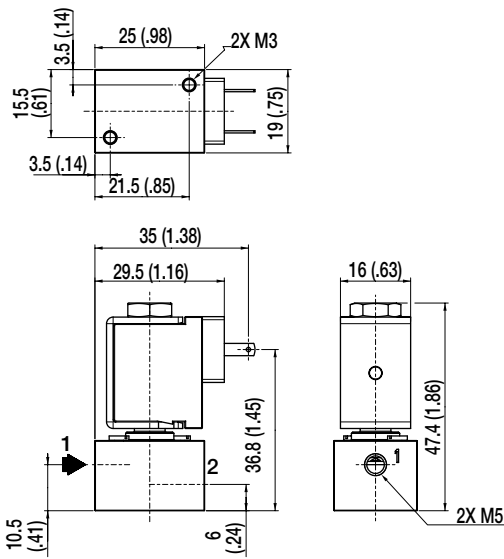

SCG202A501/A502/A503/A504

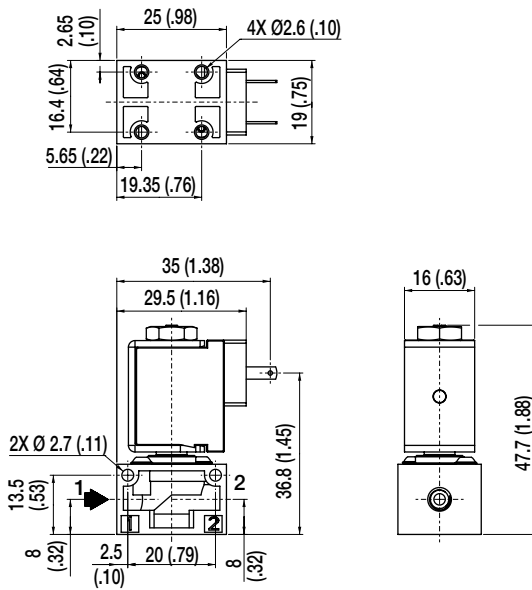

SCS202A505/A506/A507/A508/A509
(Version with ISO 15218 interface for installation on single subbase M5)

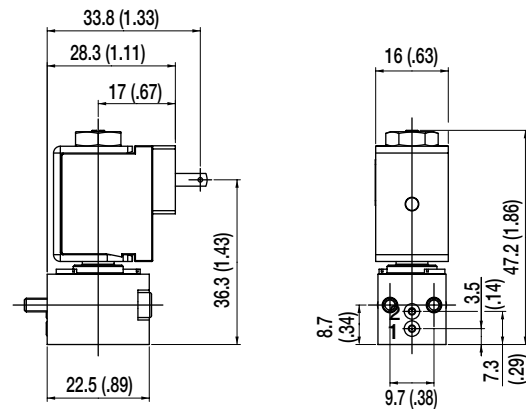

ISO 15218 Mounting Pattern

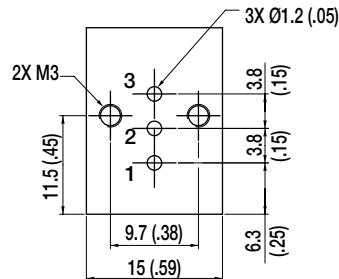

01029GB-2020-R01

Dimensions: mm (inches)

Type 02-03

Prefix "SC" solenoid, epoxy molded
IEC 335/DIN 43650 or ISO 4400
IP65



Type 02 : SCG202A510/A511/A512
Type 03 : SCG202A513
With 22 mm Coil Version

Type 03 : SCG202A513_24V
With 30 mm Coil Version

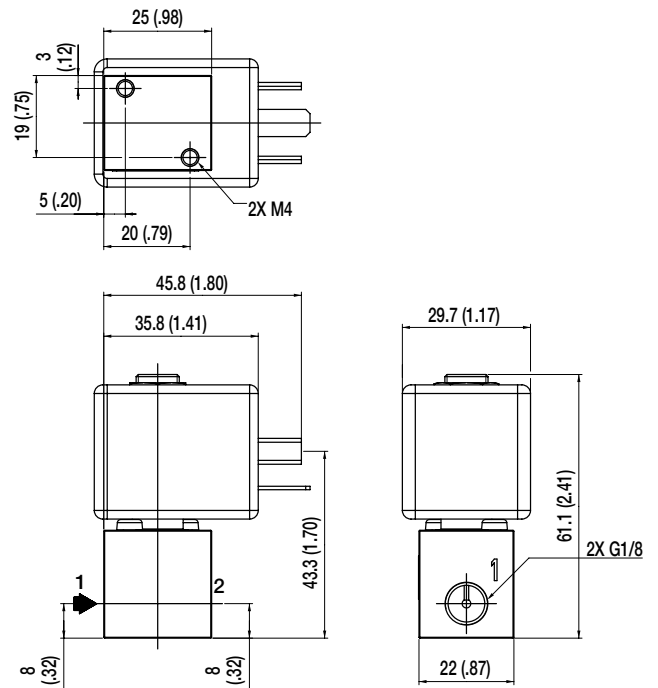
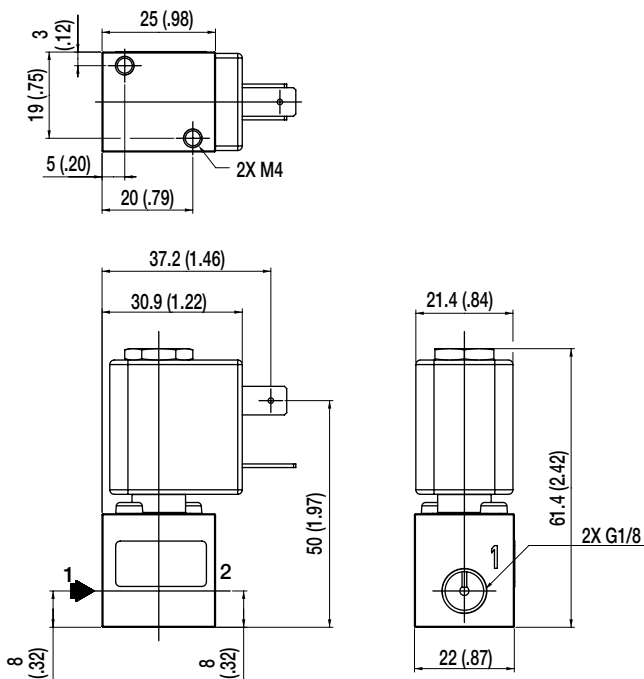

Single Subbase M5

Aluminum or brass

88263002 - 30300001

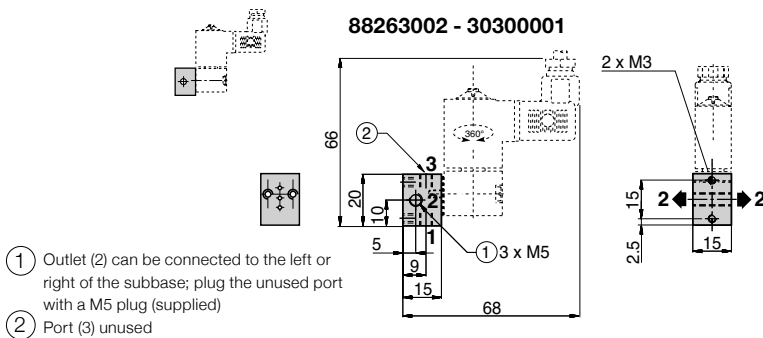

- ① Outlet (2) can be connected to the left or right of the subbase; plug the unused port with a M5 plug (supplied)
- ② Port (3) unused

ASCO™ MINIATURE SOLENOID VALVES

PROPORTIONAL VALVES, PRECIFLOW IPC, PRECIFLOW 19mm

- Preciflow solenoid valves are designed to proportionally control the flow of air and inert gases by varying the electrical input signal to the coil
- Low hysteresis (typ. < 5%), excellent repeatability (typ. < 1%), and high sensitivity (typ. < 1%) make these valves ideal for high precision flow control
- Compact frictionless architecture saves valuable space in analytical and medical instrumentation
- Valves do not require a minimum operating pressure
- Low power consumption to meet the most stringent instrument power requirements
- Meets all relevant CE directives, and is RoHS compliant
- Typical applications include:
 - Respiratory Therapy
 - Gas Chromatography
 - Blood Pressure Monitoring
 - Anesthesia Delivery

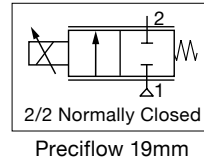
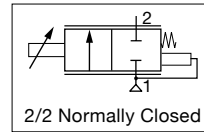

Version	Fluids*	Temperature Range	Seal Materials*
Preciflow IPC	Air or Inert Gases ¹	10 °C to 50 °C (50 °F to 122 °F)	Preciflow IPC: FKM, NBR
Preciflow 19mm		0 °C to 50 °C (32 °F to 122 °F)	Preciflow 19mm: FKM (EDPM or FFKM on request)

* Ensure that the compatibility of the materials in contact with the fluids is verified.
¹ Filtration: 5µm

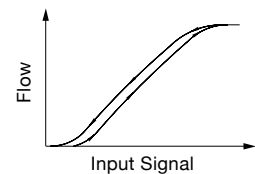

General Valve Information		
	Preciflow IPC	Preciflow 19mm
Body	Stainless Steel and Brass (Line Mount) or POM (Pad Mount)	Stainless Steel
Others	Stainless Steel, FKM, PPS	POM, Brass, Stainless Steel, PPS
Max. Viscosity	50 cSt (mm ² /s)	

Electrical Characteristics	
Coil Insulation Class	F
Connector	Lead Wires (PTFE/ ETFE); 0.23m (9in) length (24 AWG)
Electrical Safety	IEC 335
Electrical Enclosure Protection	IP50 (EN 60529)
Standard Voltages ²	6 VDC, 12 VDC, 24 VDC
Input signal	0-6 VDC, 0-12 VDC, 0-24 VDC; Pulse-width Modulation (min. 2000Hz), Current control recommended
Flow Regulation Characteristics	Hysteresis < 5%; Repeatability < 1%; Sensitivity < 1%

² Other voltages on request

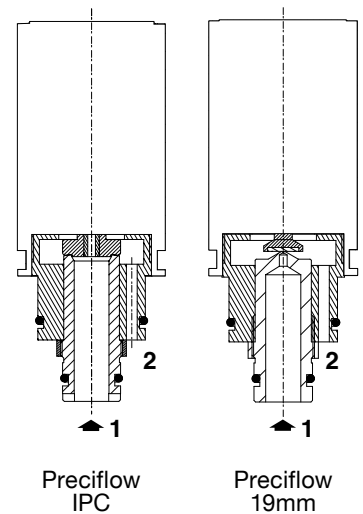

Voltage	Max. Operating Current	Power Ratings				Ambient Temperature Ranges	Type ³
		Inrush	Holding	Hot/Cold	Hot/Cold		
V	mA	VA	VA	W	W	°C (°F)	
Preciflow IPC							
6	420	-	-	-	2.5	10 to 50 (50 to 122)	01
12	210						
24	110						
Preciflow 19mm							
6	max. 90	-	-	-	0.5	0 to 50 (32 to 122)	01
	max. 420				2.5		
12	max. 45				0.5		
	max. 210				2.5		
24	max. 25				0.5		
	max. 110				2.5		

³ Refer to the dimensional drawings on the following pages

01011GB-2020-R01

Specifications							
Connection	Orifice Size mm (inches)	Flow Coefficient		Operating Pressure bar (psi)		Power Rating w	Catalog Number
		Kv (m ³ /h)	Cv	min.	max. air, inert gas		
Preciflow IPC*							
G1/8	3 (0.12)	0.17	0.20	0	7 (102)	2.5	LG202A514
Cartridge	3 (0.12)	0.17	0.20				LS202A515
Pad Mounting	3 (0.12)	0.17	0.20				LS202A516
* Backpressure: max. 10% of inlet pressure							
Preciflow 19mm							
Cartridge	0.1 (0.004)	0.0003	0.00035	-0.9 (-13)	10 (145)	0.5	LS202A517
	0.2 (0.008)	0.0012	0.0014				LS202A518
	0.5 (0.020)	0.0072	0.0083			2.5	LS202A519
	0.8 (0.031)	0.015	0.017				LS202A520
	1.2 (0.047)	0.021	0.024				LS202A521
	1.6 (0.063)	0.028	0.032				LS202A522

How to Order

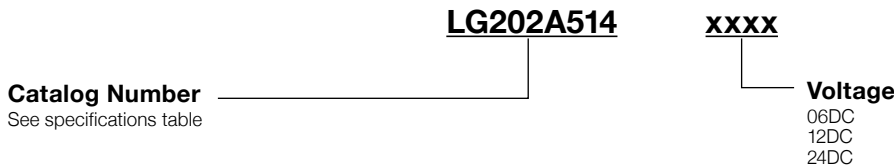

ASCO™ MINIATURE SOLENOID VALVES

PROPORTIONAL VALVES, PRECIFLOW IPC, PRECIFLOW 19mm

Dimensions: mm (inches)

Preciflow IPC

Type 01 Prefix "L" Leaded Coil
IP50

LG202A514 (Brass)

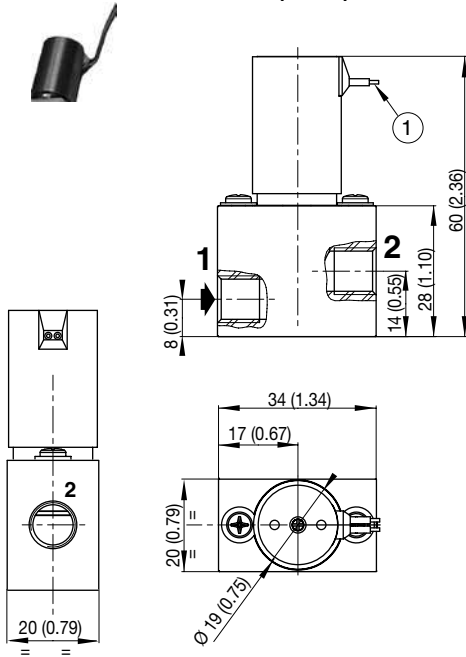

LS202A515 (Stainless Steel)

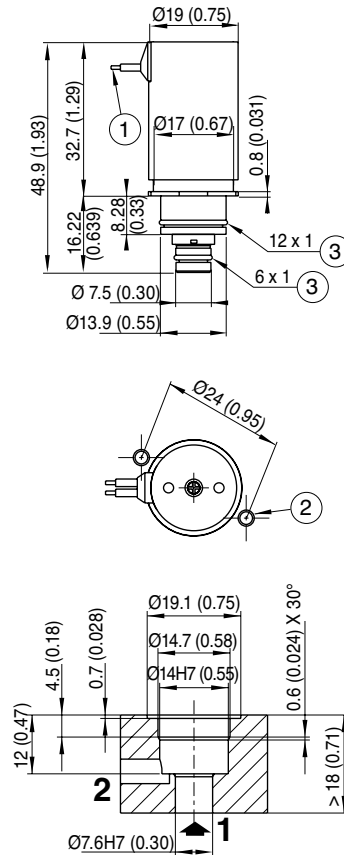

LS202A516 (POM)

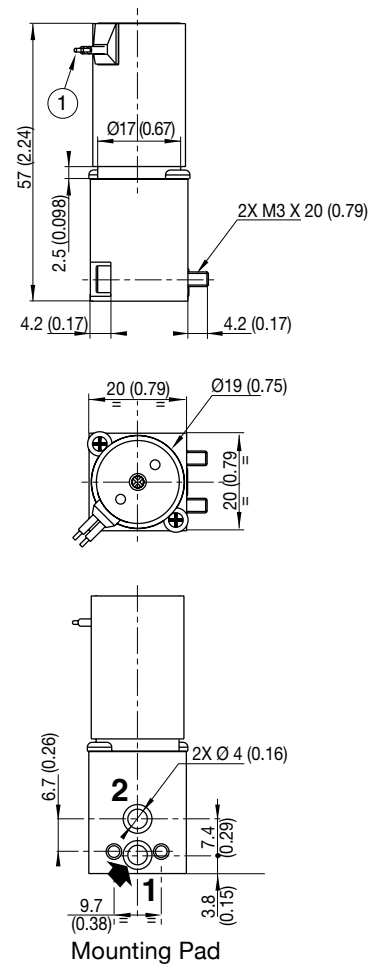

- ① 2 electrical supply wires, length: 0.23m (9in)
- ② Mounting: 2 screws M3 x 6mm (0.24in) + washers
- ③ O-ring

Mounting Geometry (Proposal)

Type	Catalog Number	Weight 1
		kg
01	LG202A514	0.183
	LS202A515	0.063
	LS202A516	0.073

1 Including leads, length 0.23m (9in)

01011GB-2020-R01

Dimensions: mm (inches)

Preciflow 19mm

Type 01 Prefix "L" Leaded Coil
IP50
Preciflow 19mm Cartridge

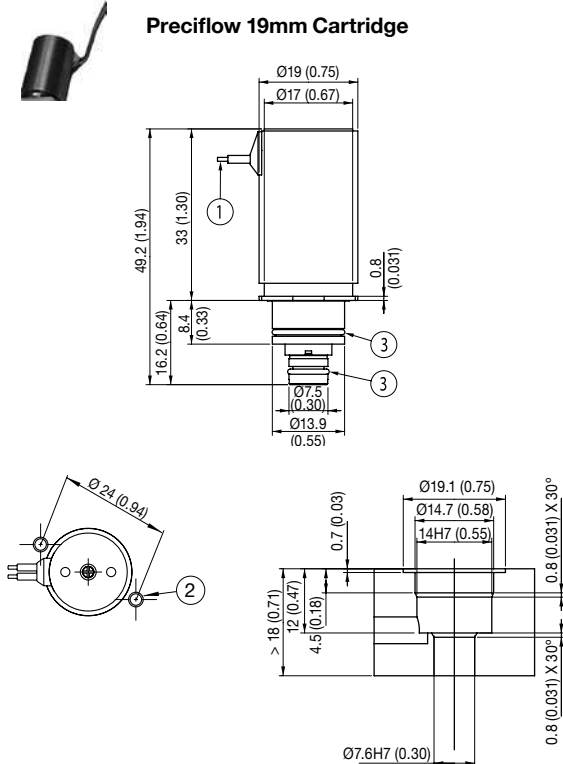

- ① 2 electrical supply wires, length: 0.23m (9in)
- ② Mounting: 2 screws M3 x 6mm (0.24in) + washers
- ③ O-ring

Catalog Number	Weight kg
LS202A517/518/519/520/521/522	0.063 ¹
528190-001	0.012kg
526624-001	0.013kg

¹ Including leads, length 0.23m (9in)

Options

- Digital control module Control^D for DIN EN 50022 rail mounting (for more information see specifications on page 185)
- Other pipe connections are available on request
- Other seal materials are available on request
- Version for higher backpressure on request (only Preciflow IPC)

Pad Mount Subbase 526624-001
POM (supplied with 2 screws M3x20 and O-rings)

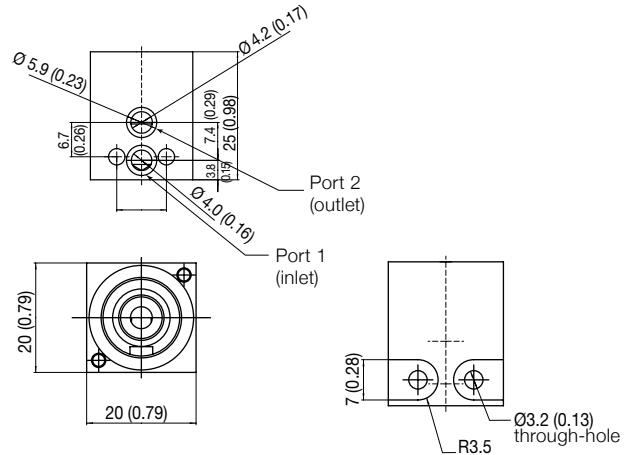

Inline Subbase 528190-001
Brass (supplied with 2 screws M3x6)

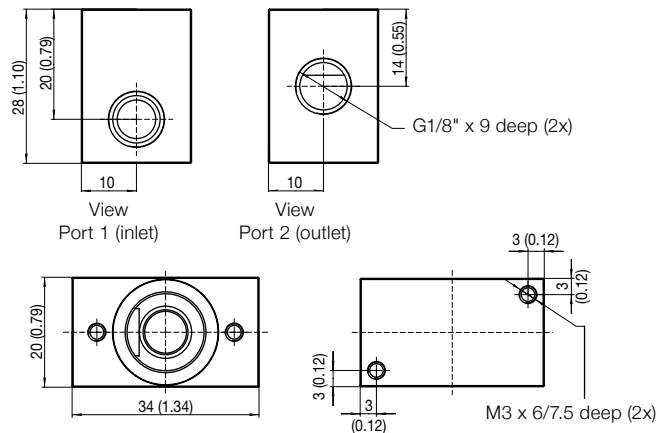

Installation

- The solenoid valves can be mounted in any position without affecting operation
- Pipe connection identifier is G = G (ISO 228/1)

AVENTICS™ PROPORTIONAL VALVE SENTRONIC^{PLUS} IPC

DIGITAL ELECTRONIC PRESSURE REGULATOR, IO-LINK CLASS A

- SENTRONIC^{PLUS} IPC is a highly dynamic 2/2-way proportional valve with digital control.
- IO - Link CLASS A Version
- RoHS, REACH compliant
- The very low friction mechanic delivers precise control behaviour, especially in flowing conditions.



General Valve Information	
Fluids	Air or neutral gases, Class 5 according to ISO 8573-1:2010 [7:4:4]
Ports	G 1/8 , 1/8 NPT
Max. allowable pressure	Varies by outlet pressure range. See How to Order on next page.
Pressure range	See table below
Fluid temperature	0...50 C° (32...122°F)
Ambient temperature	0...50 C° (32...122°F)
Setpoint	Digital setpoint in steps of 1 mbar 0-10000 = 0-10 bar
Hysteresis	0.5 % of span
Linearity / pressure measurement	± 0.5 % of span
Repeatability	± 0,5 % of span

Construction	
Body	Aluminium
Internal parts	Stainless steel and aluminium
Seals	FPM

IO-Link	
Protocol version	Specification V1.1
Baud rate	COM3 (230.4 kBaud)
Minimum cycle time	0.5 ms
Process data	2 Byte IN, 2 Byte OUT
Port type	Class A

Electrical Characteristics						
Nominal diameter DN	Voltage *	Max. power (W)	Max. current (mA)	Insulation class	Degree of protection	Electrical connection
3	24VDC +/-10%	5	210	F	IP30	5-pin M12 connector (to be ordered separately)

* Max. ripple: 10 %

Specifications				
Pipe size	Orifice size (mm)	Flow at 6 bar		
		Flow Coefficient		(l/min)
	Kv (m ³ /h)	Cv		
G/NPT 1/8	3	0.17	0.20	150

01603GB-2019-F01

How to Order

CATALOG NUMBER

6 1 4 3 5 7 B A S I D P P

B: CONTROL PANEL

B = IO-Link with display
C = IO-Link without display

A: VERSION (ports), body

W = 2/2 NC, G1/8
P = 2/2 NC, 1/8 NPT

S: SETPOINT

B = IO-Link Class A

I: FEEDBACK

B = IO-Link Class A

PP: PRESSURE RANGE

Relative pressure	Max. allowable pressure (bar)	Vacuum (relative)
40 = 0 - 100 mbar	2	V2 = 0 ... -1 bar
50 = 0 - 500 mbar	2	Bypass version
60 = 0 - 1 bar	2	V3 = 0 ... -1 bar
02 = 0 - 2 bar	3	Shut-off valve
03 = 0 - 3 bar	7	(vacuum at port 1)
05 = 0 - 5 bar	7	
06 = 0 - 6 bar	7	

D: OUTPUT

1 = Standard

AVENTICS™ PROPORTIONAL VALVE SENTRONIC^{PLUS} IPC
DIGITAL ELECTRONIC PRESSURE REGULATOR, IO-LINK CLASS A

Dimensions: mm (inches)

G/NPT 1/8

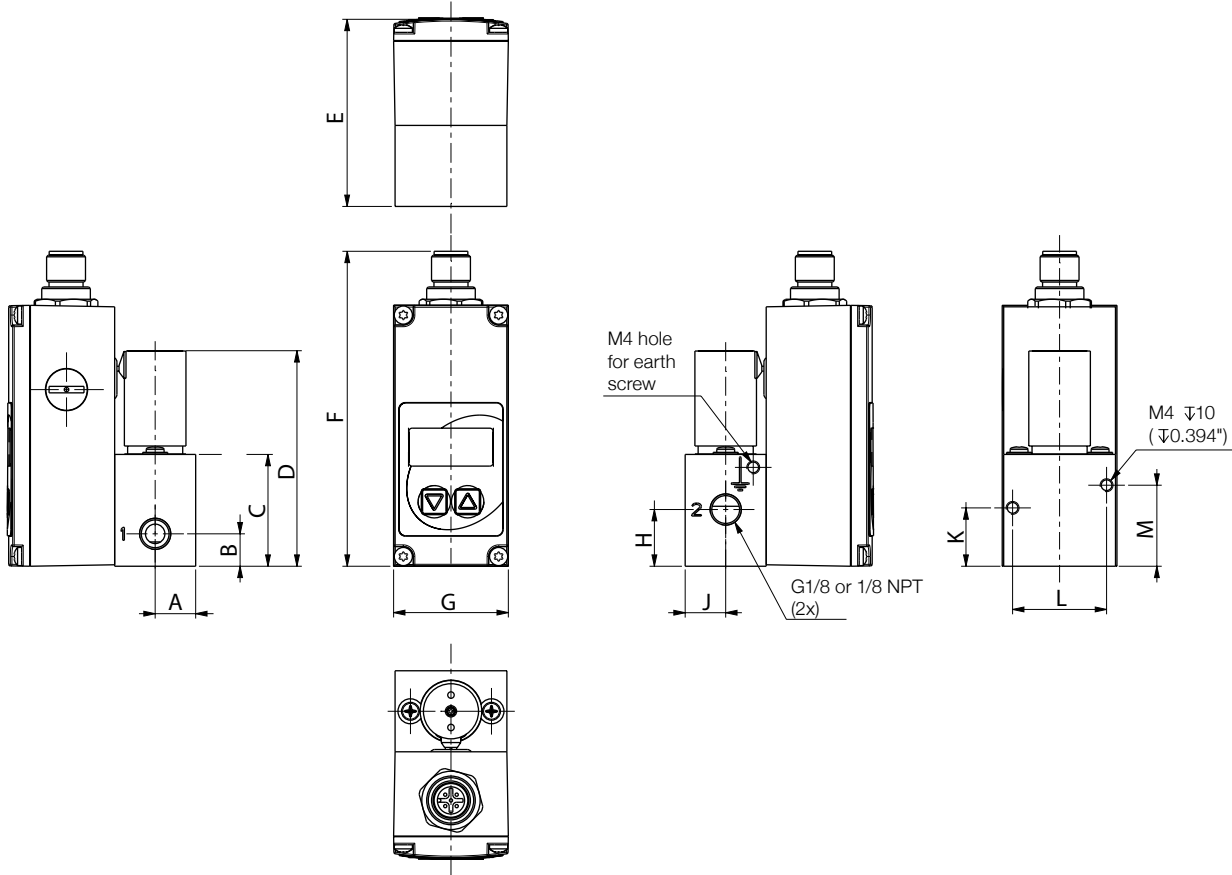

Catalog Number	A	B	C	D	E	F	G	H	J	K	L	M	Weight kg (lbs)
614357XXXXXXXX	12.5 (0.492)	10 (0.393)	34.5 (1.358)	66.5 (2.618)	57.7 (2.27)	97 (3.819)	35.4 (1.393)	17.5 (0.689)	12.5 (0.492)	18 (0.708)	29 (1.142)	25 (0.984)	0.250 (0.551)

01603GB-2019-R01

Pin Assignment / Cable Assignment

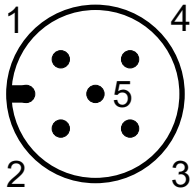

Pin	Description
1	24V voltage supply
2	not connected
3	Supply ground
4	C/Q
5	not connected
Body	EMC shield

ACCESSORIES	
Description	Catalog Number
Connection cable 5m, straight socket, open cable end	N15183710000000
Connection cable 10m, straight socket, open cable end	N15183840000000
Connection cable 5m, straight socket on straight connector	N15184490000000
Connection cable 10m, straight socket on straight connector	N15184520000000

ASCO™ MINIATURE SOLENOID VALVES

PROPORTIONAL VALVES, MINIATURE PIEZOTRONIC

- Miniature, ultra-low power consumption (0.004 W), almost no heat dissipation
- Pad mounting proportional mini piezo-valves available with single subbase M5
- Variable flow, proportional to the control signal
- No wearing parts: practically unlimited service life
- No inductive peaks when switching: no circuit protection necessary
- Valves do not require a minimum operating pressure
- The solenoid valves satisfy all relevant EC directives
- Typical applications include:
 - Gas Chromatography
 - Mass Flow Controllers
 - Dental Equipment
 - Blood Pressure Monitoring

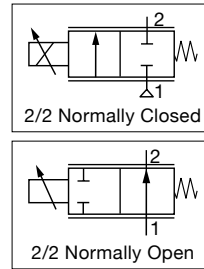

Fluids*	Temperature Range	Seal Materials*
Air or Inert Gases ¹	0 °C to 60 °C (32 °F to 140 °F)	NBR

* Ensure that the compatibility of the materials in contact with the fluids is verified.
¹ Filtration: 5µm, unlubricated, condensate free, dew point -10 °C

General Valve Information	
Body	PPS
Others	Piezo Ceramics, Brass, Aluminum

Electrical Characteristics	
Coil Insulation Class	F
Connector	Spade plug or cable 6-7mm (0.24-0.28in)
Connector Specification	DIN 43650, 9.4mm, form C or 2 leads outlet 28 AWG, length 1m (39.4in)
Electrical Safety	IEC 335
Electrical Enclosure Protection	Molded IP65 (EN 60529)
Voltage Regulation	0 – 40 VDC
Flow Regulation Characteristics	Hysteresis < 10% to 15%

ELECTRICAL CONNECTION (Polarized piezo valve)

Version with spade plug connection:

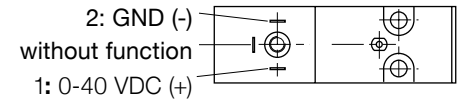

Version with 2 leads:
 red wire: +
 black wire: -

Holding Current	Power Ratings				Ambient Temperature Ranges	Type ²
	Inrush	Holding	Hot/Cold			
mA	VA	VA	W	W	°C (°F)	
< 100	-	-	-	0.004	0 to 60 (32 to 140)	01-02

² Refer to the dimensional drawings on the following page

Specifications											
Connection	Flow Coefficient		Operating Pressure bar (psi)			Holding Power	Catalog Number				
			min.	max. air			W	without manual operator		with impulse manual operator	
	Kv (m3/h)	Cv				connector	leads	connector	leads		
2/2 NC - Normally Closed											
Pad Mounting	0.005	0.006	0	-	8	-	0.004	63000075	63000035	63000079	63000039
	0.007	0.008	0	-	4	-	0.004	63000076	63000036	63000080	63000040
2/2 NO - Normally Open											
Pad Mounting	0.005	0.006	0	-	8	-	0.004	63000077	63000037	63000081	63000041
	0.007	0.008	0	-	4	-	0.004	63000078	63000038	63000082	63000042

Subbases ³				
Connection	Mounting Type	Description	Catalog Number	
			aluminum	brass
M5	individual mounting	M5 lateral connection	88263002	30300001

³ Multiple subbases available upon request

00018GB-2019/R01

Dimensions: mm (inches)

Type 01 IEC 335/DIN 43650
IP65
63000075/76/77/78/79/80/81/82

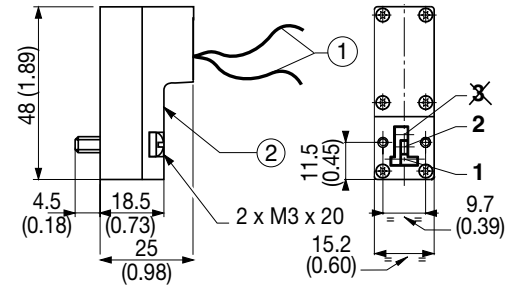
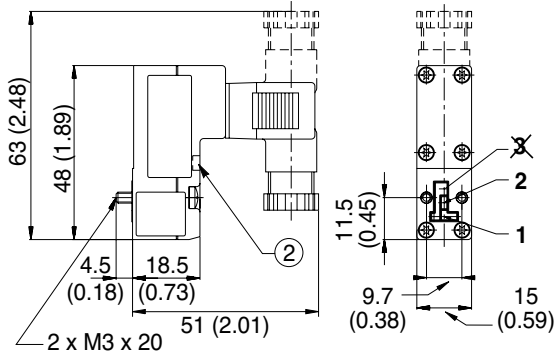

Type 02 IEC 335
IP65
63000035/36/37/38/39/40/41/42

Single Subbase M5
Aluminum or brass
88263002 - 30300001



Subbase Mounting Pattern
ISO 15218/CNOMO
E06.36.120N, size 15

- ① 2 leads 28 AWG, length: 1m (39.4in)
- ② Manual operator location
- ③ Outlet (2) can be connected on the left or on the right of subbase; close the unused port with a Ø M5 plug (supplied)
- ④ Port (3) not used (to be provided with protection)

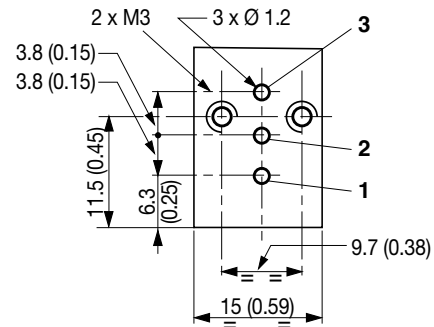
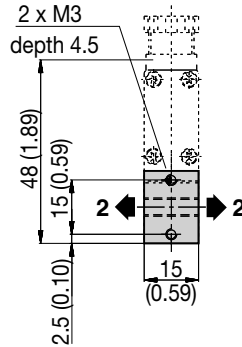
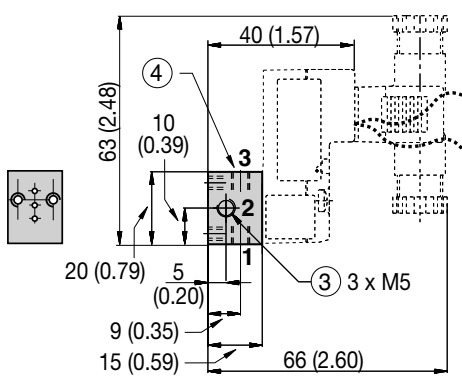
Type	Catalog Number	Weight
		kg
01	63000075/76/77/78/79/80/81/82	0.040
02	63000035/36/37/38/39/40/41/42	0.032
-	88263002	0.012
-	30300001	0.034

Options

- Plug with cable length of 2m (78.8in)

Installation

- The solenoid valves can be mounted in any position without affecting operation
- Mounting on single subbases
- Unlike the on/off type, the proportional version is not equipped with electronics. Please check for correct polarity when connecting the valve. The piezo element will be damaged if the polarity of the connections is inverted. The control system of the user must be used for charging and discharging.

Important Note: The peak current must be limited by series resistor greater than 30 ohms

ASCO™ MINIATURE SOLENOID VALVES

DENTAL MANIFOLD

- 3 manifolds with the following configurations:
 - Manifold with 2 microactuators 2/2NC (A-P) and 1 total isolation microactuator 2/2NC (W); all direct acting.
 - Manifold with 1 microactuator 2/2NC (A), 1 total isolation microactuator 2/2NC (W) and 1 proportional solenoid valve 2 ways NC (P); all direct acting.
 - Manifold with 1 total isolation direct acting microactuator 2/2NC (W), 1 water channel (P) and 1 air channel (A).
- Compact and versatile version, designed for dental equipments; equipped with 3 flow regulators. The modular system allows the use as single or as a set (max. 4 manifolds); the manifold is delivered with 3 sealing O-rings and joint pin. Heads group kit (feeding and end side) available separately (see details on the back).
- Suitable to shut off liquid (W) and gaseous (A-P) fluids (verify the compatibility of fluid with materials in contact). Pipette Dispensing

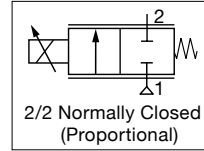
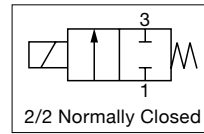

Series 252 D01



Series 252 D02



Series 252 D03

Fluids*	Temperature Range	Seal Materials*
Liquids or Gases	-10°C to 90 °C (50°F to 194°F)	EPDM

* Ensure that the compatibility of the materials in contact with the fluids is verified..

General Valve Information	
Body	POM
Others	Stainless Steel / PA 66 / Brass
Response Time	< 10ms
Max. Viscosity	22 cSt (mm ² /s)

Electrical Characteristics	
Coil Insulation Class	F
Connector	- DIN 46340 with micro plug connector - Lead Wires
Electrical Safety	EN 60730-1
Electrical Enclosure Protection	IP65 (EN 60529), IP40 (EN 60529)
Standard Voltages*	12 VDC, 24 VDC (-5%/+10%), Proportional valve (P): 70 – 220 mA (24V)

* Other voltages on request

Coil Type	Power Ratings	Ambient Temperature Range	Protection	Electrical Connection
	W	°C (°F)	VA	W
Standard S0	4	10 to 60 (50 to 140)	IP65	Spade terminals 2.8 x 0.5 (DIN 46340)
Standard L0	4	10 to 60 (50 to 140)	IP65	500mm Lead Wire (for D01 and D03) - 460mm/500mm Lead Wire (for D02)
Proportional S0	5.5	10 to 60 (50 to 140)	IP65	Spade terminals 2.8 x 0.5 (DIN 46340)
Proportional L0	5.5	10 to 60 (50 to 140)	IP65	500mm Lead Wire (for D01 and D03) - 460mm/500mm Lead Wire (for D02)

01074GB-2019-R01

Specifications								
Type	Orifice Size	Flow Coefficient		Operating Pressure. bar (psi)			Power Rating (W)	Catalog Number
				min.	max.			
	mm (inches)	Kv (m ³ /h)	Cv			gases		
D01	1.6 (0.063)	0.030	0.035	0	6 (87)	-	4	6252AD01
	1.8 (0.071)				6 (87)	-	4	
	1.5 (0.059)				-	3 (43.5)	4	
D02	1.6 (0.063)	0.030	0.035	0	6 (87)	-	4	6252AD02
	1.6 (0.063)	-	-		6 (87)	-	5.5	
	1.6 (0.063)	0.030	0.035		-	3 (43.5)	4	
D03	1.5 (0.059)	0.030	0.035	0	-	3 (43.5)	4	6252AD03

How to Order

6 252 A D01 S0 A00 F1

Connection Type

6 = Barb Fitting

Product Series

252 = Dental Manifold Module

Revision

A = Initial Release

Pipe Size / Orifice

D01 = Orifice size: 1.6 / 1.8 / 1.5. 2-Way N.C.

D02 = Orifice size: 1.6 / 1.6 Proportional / 1.5. 2-Way N.C.

D03 = Orifice size: 1.5. 2-Way N.C.

Voltage

F1 = 24/DC Class F

F3 = 12/DC Class F

Options

A00 = No Options

Electrical Connection Type

S0 = Din Type Coil

L0 = 500mm Leaded coil (for D01 and D03)

460mm/500mm Leaded coil (for D02)

Accessories

Heads group kit

Description	Series	Catalog Number
Heads group kit Consisting of: feeding head, end side head, screw, sealing, pin	252	M252AU529833001

01074GB-2019-R01

ASCO™ MINIATURE SOLENOID VALVES

DENTAL MANIFOLD

Dimensions: mm (inches)

Type 1 / D01

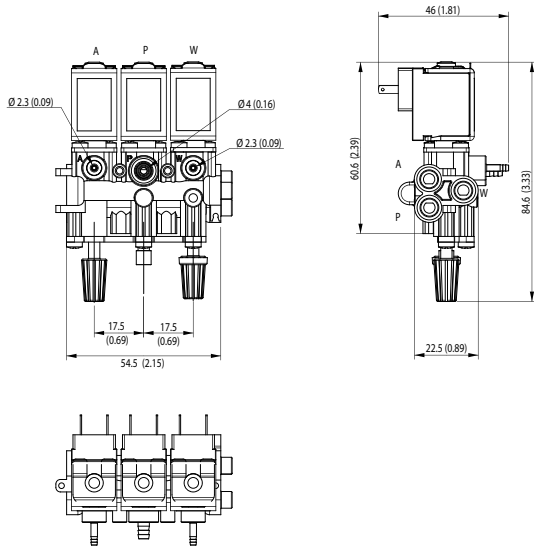

Type 2 / D02

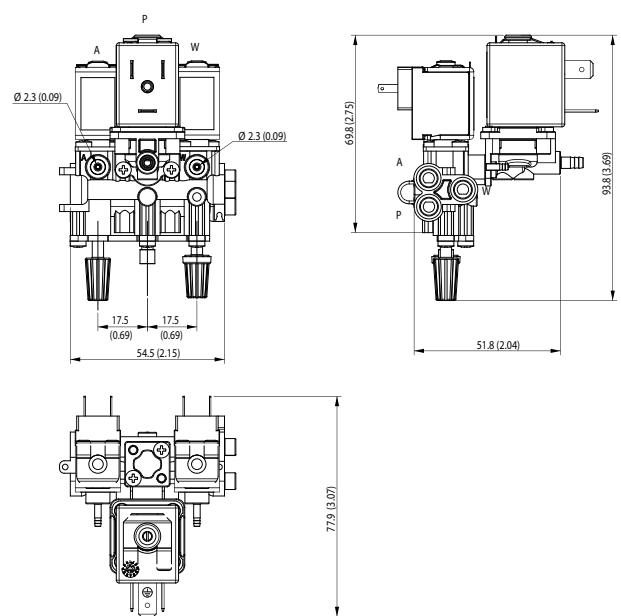

Type 3 / D03

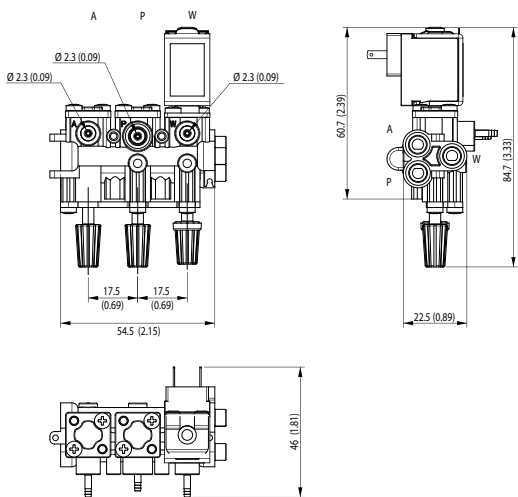

01074GB-2019-R01

ASCO™ MINIATURE PRESSURE REGULATOR

NON-RELIEVING MANIFOLD MOUNT

The Series 624 non-relieving regulator is designed to control system pressure to a constant maximum set point.

- Lightweight, compact manifold mount interface for easy installation and maintenance
- Output pressure ranges 0-0.7 bar (0-10 psi), 0-1.4 bar (0-20 psi), 0.4 - 2.1 bar (5 - 30 psi)
- Suitable for use in a wide variety of gas applications, and is an excellent choice for use with 95% concentrated oxygen
- Excellent for oxygen therapy and ventilation applications
- Typical applications include:
 - Oxygen Concentrators
 - Respiratory Therapy
 - Ventilators



Fluids	Temperature Range	Seal Materials*
Air, Inert & Neutral gases, or Oxygen	0C° to 60C° (32F° to 140F°)	CR, NBR

* Ensure that the compatibility of the materials in contact with the fluids is verified

Manifold Construction	
Body	POM
Internal Components	POM
Function	Non-Relieving Regulator
Inlet Fitting	1/8" NPT
Outlet Fitting	Barb for 1/4" I.D. Tubing

Alternate Construction Options

Additional options are available including alternative inlet and regulated pressure ranges. Minimum quantities apply.

Specifications					
Port Type	Inlet Pressure	Regulated Pressure		Flow (slpm) ⁽¹⁾	Catalog Number
	Max bar (psi)	Min bar (psi)	Max bar (psi)		
Manifold	6.9 (100)	0.0 (0)	0.7 (10)	74	8624A501
	6.9 (100)	0.0 (0)	1.4 (20)	109	8624A502
	6.9 (100)	0.4 (5)	2.1 (30)	112	8624A503

(1) Inlet pressure set at 100psig, outlet set at maximum regulated pressure, flow rate at 15% pressure drop from maximum regulated pressure

To Order

- Select catalog number from specification table above
- Additional seal materials available on request

01073GB-2019-R01

How to Order

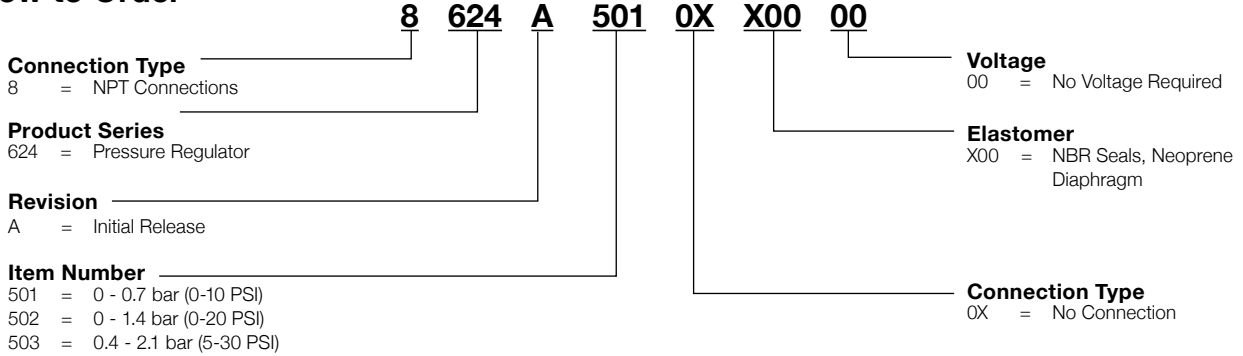

Dimensions: mm (inches)

Port Type: Manifold
Weight: 35.4g (1.25oz)

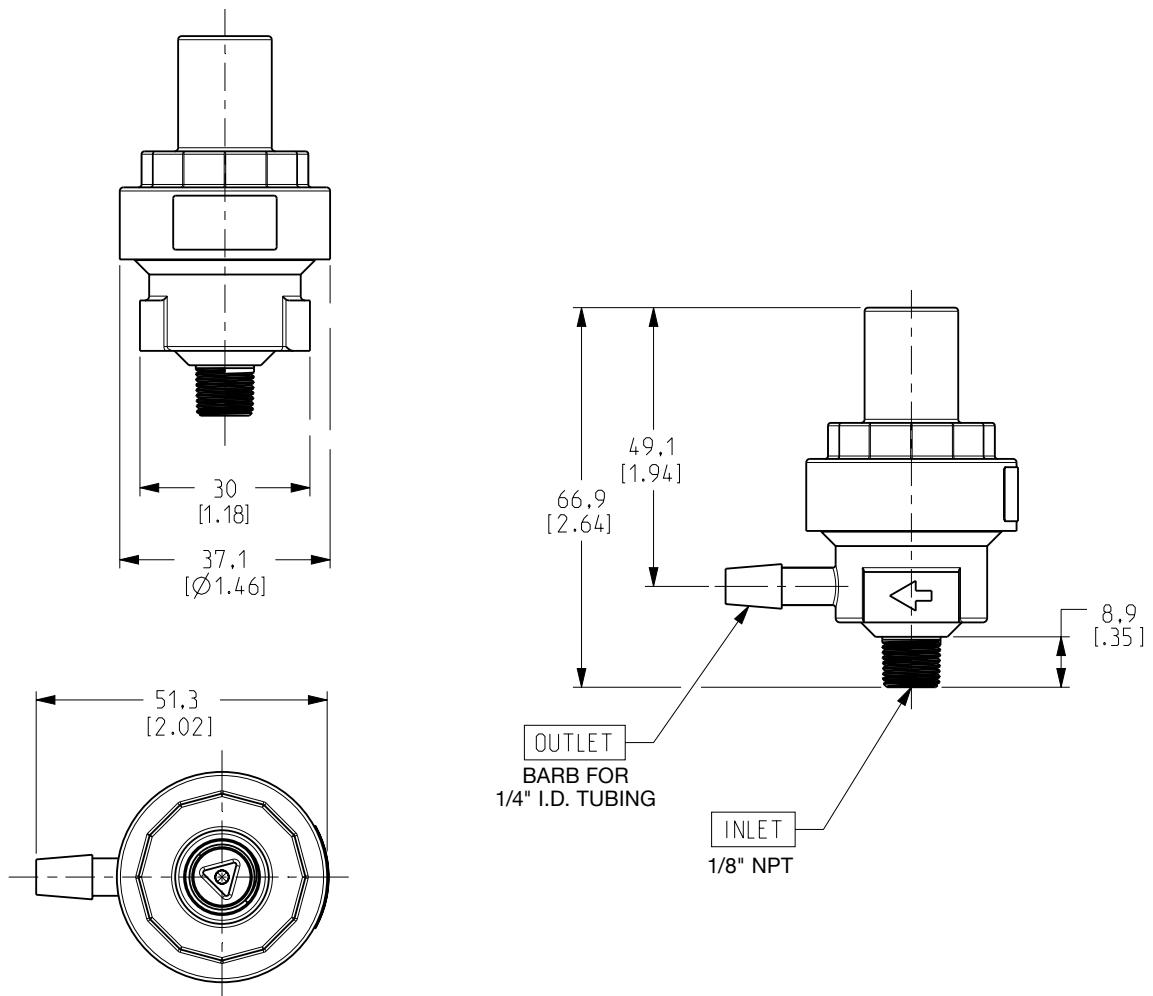

01073GB-2019-R01

DIN ELECTRICAL CONNECTORS

- Spade connector to fit standardized three-pin molded coils:
 - Size 22 connector with 11mm (0.43in) between contacts: EN 175301-803, industry standard form B, for coil types CM5, CM22, C22A, EMX and BMX
 - Size 30 connector with 18mm (0.71in) between contacts: ISO 4400/EN 175301-803 form A, for coil types CM6, CMXX, CM12, CM25, C25A, CM30, CM40, ANX, AMX, JMX, FNX and FMX
- The connectors are available in two versions: standard rotatable version with or without integrated visual LED indicator and electrical protection, or version with non-rotatable 3-core molded-in cable, 2m (78.7in) long
- The standard connector with 18mm contacts is provided with a removable lid allowing access to the wiring for easy checking of power supply without unplugging the connector and without interrupting operation of the solenoid valve



Connector Specification		Max. Operating Temperature
11mm between contacts (0.43in)	18mm between contacts (0.71in)	
EN 175301-803 industry standard form B	ISO 4400/EN 175301-803, form A	-40 °C to 80 °C (-40 °F to 176 °F), -40 °C to 125 °C (-40 °F to 257 °F) with silicone seal [version with molded-in cable -5 °C to 70 °C (23 °F to 158 °F)]

Construction	
Standard version	PA (polyamide), glass-fiber reinforced
Enclosure with LED and protection	PA
Enclosure with PVC cable	PA (polyamide), glass-fiber reinforced
Seals	NBR [option for 18mm contacts: VMQ (silicone)]

Electrical Characteristics		
	11mm between contacts (0.43in)	18mm between contacts (0.71in)
Number of contacts	2 + common ground	2 + common ground
Contact resistance	≤ 4m Ω	≤ 4m Ω
Connector	Spade plug	Spade plug
Electrical safety	IEC 335	IEC 335
Electrical enclosure protection	IP65 (EN 60529)	IP65 (EN 60529)
Number of wires (with cable)	3	3

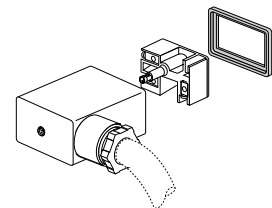

Rotatable Connector

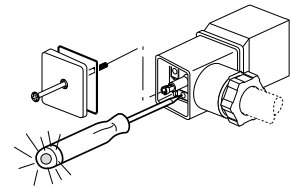

Standard Rotatable Connector with Power Supply Control

LED Indicator and Electrical Protection Diagrams

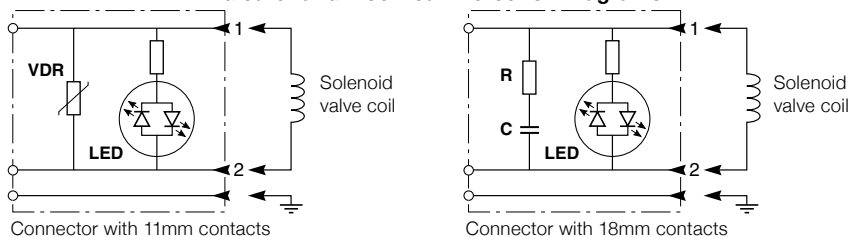

VDR Varistor absorbing the self-inductance of the coil
RC RC circuit absorbing the self-inductance of the coil
LED Green light-emitting diode, bidirectional, signalling the presence of voltage across the coil terminals

Specifications									
Description	Cable Length	Cable O.D.		Wire Cross-Section	Max. Voltage	Type	Catalog Number		
		11mm	18mm				11mm	18mm	
	m (inches)	mm (inches)		mm ²	V	NBR	NBR	VMQ*	
Rotatable Connector									
Standard, Without LED Indicator	-	6 to 8 (0.24 to 0.31)	6 to 10 (0.24 to 0.40)	1.5	250	01-02	290414-001	290411-001	88122625
With Integrated LED Indicator and Electrical Protection	-	6 to 8 (0.24 to 0.31)	8 to 10 (0.31 to 0.40)	1.5	12	01-02	-	88122611	-
					24		290415-024	290412-024	-
					48		-	290412-048	-
					115		290415-120	290412-120	-
230	290415-240	290412-240	-						
Non-rotatable Connector with Cable									
Without LED Indicator	2 (78.7)	-	-	1.5	250	03-04	88122413	88122612	-

* For use within class H temperature limits

00142GB-2019-F01

Dimensions: mm (inches)

Type 01 11mm (0.43in) Lead Wires
EN 175301-803, industry standard form B
IP65

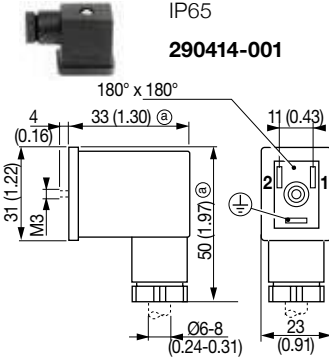

290414-001

290415-024/120/240

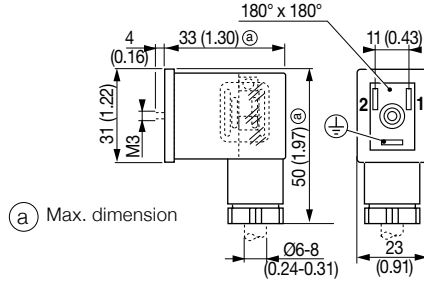

290414-001/024/120/240

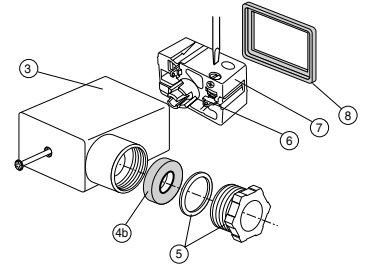

Type 02 18mm (0.71in) Lead Wires
ISO 4400/EN 175301-803, form A
IP65

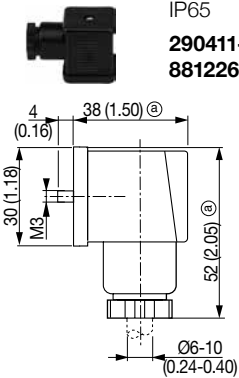

**290411-001
88122625**

290412-024/048/120/240

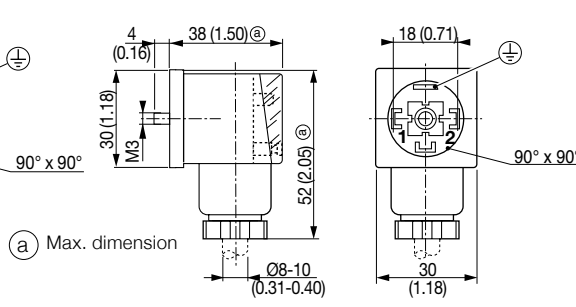

**290411-001
88122625**

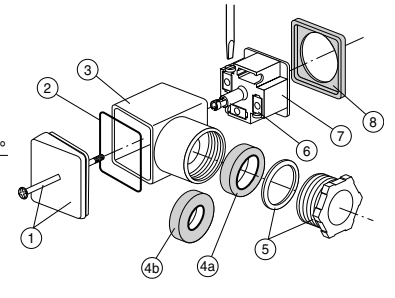

Type 03 11mm (0.43in) Lead Wires
EN 175301-803,
industry standard form B
IP65 (non-rotatable terminal holder)
88122413

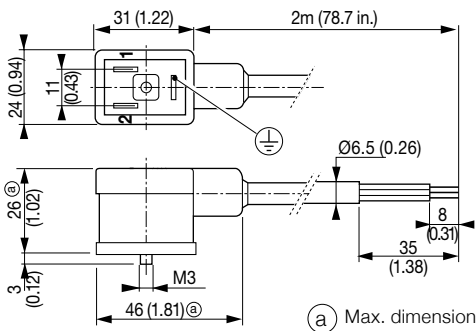

Type 04 18mm (0.71in) Lead Wires
ISO 4400/EN 175301-803, form A
IP65 (non-rotatable terminal holder)
88122612

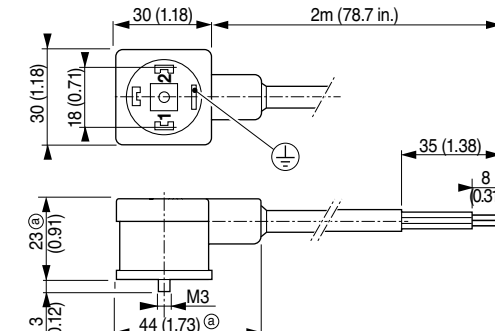

- 1 Fastening screw/cover
- 2 Cover seal
- 3 Enclosure
- 4 **88122602/625:**
2 seals for cable dia. 8 to 10mm (4a)
or cable dia. 6 to 8mm (4b)
- 88122611/603/604/605/608:**
1 seal for cable dia. 8 to 10mm (4a)
- 88122404/405/406/407/410:**
1 seal for cable dia. 6 to 8mm (4b)
- 5 Stuffing box washer and nut
- 6 Cable connection terminal
- 7 Terminal holder
- 8 Connector seal

Installation

- The connectors can be mounted in any position without affecting operation

Sizes 03 and 04	
brown wire	terminal 1 (+)
blue wire	terminal 2 (-)
green/yellow wire	ground

Type	L m (inches)	Weight ¹ (kg)	
		without LED indicator	with LED indicator
01	-	0.025	0.025
02	-	0.030	0.032
03	2 (78.7)	0.150	-
04	2 (78.7)	0.155	-

¹ Including seals and screws

DIN ELECTRICAL CONNECTORS

- Spade connector to fit standardized three-pin molded coils:
 - EN 175301-803, industry standard form C (9.4mm), for coil type CM15 (202 Series), DMX and 302, 630, 519, 520, 521 and 578 Series (MEGA)
 - EN 175301-803, form C (8mm), for 302, 630 and 202 Series
- The connectors are available in three versions: standard rotatable version, or version with non-rotatable 3-core molded-in cable, 2m (78.7in) or 5m (196.9in) long, with or without integrated visual LED indicator and electrical protection



Connector Specification		Max. Operating Temperature
9.4mm between contacts (0.37in)	8mm between contacts (0.31in)	
EN 175301-803 industry standard form C	EN 175301-803, form C	-25 °C to 60 °C (-13 °F to 140 °F), [version with molded-in cable]

Construction	
Standard version	PA, glass-fiber reinforced
Enclosure with LED and protection	PA or PP
Enclosure with PVC cable	PP, glass-fiber reinforced
Seals	NBR

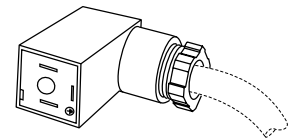

Rotatable Connector
9.4mm or 8mm

Electrical Characteristics		
	9.4mm between contacts (0.37in)	8mm between contacts (0.31in)
Number of contacts	2 + common ground	2 + common ground
Contact resistance	≤ 4m Ω	≤ 4m Ω
Connector	Spade plug	Spade plug
Electrical safety	IEC 335	IEC 335
Electrical enclosure protection	IP65 (EN 60529)	IP65 (EN 60529)
Number of wires (with cable)	3	3

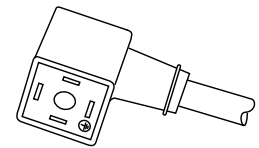

Non-rotatable Connector
with Cable

LED Indicator and Electrical Protection Diagram

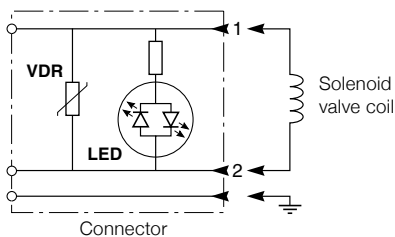

VDR Varistor absorbing the self-inductance of the coil
LED Green light-emitting diode, bidirectional, signalling the presence of voltage across the coil terminals

Specifications							
Description	Cable Length	Cable O.D.	Wire Cross-Section	Max. Voltage	Type	Catalog Number	
	m (inches)	mm (inches)	mm ²	V		9.4mm	8mm
Rotatable Connector							
Standard, Without LED Indicator	-	4 to 6 (0.16 to 0.24)	0.6	250 V	01 - 02	290417-001 (US customers) 88143581 (all other customers)	88130211
Non-rotatable Connector with Cable							
Without LED Indicator	2 (78.7)	-	0.6	250 V	03	272852-004	*
With Integrated LED Indicator and Electrical Protection	2 (78.7)	-	0.6	24 V	04	-	-
	5 (196.9)					88143593	-

* Contact us

00142GB-2019-F01

Dimensions: mm (inches)

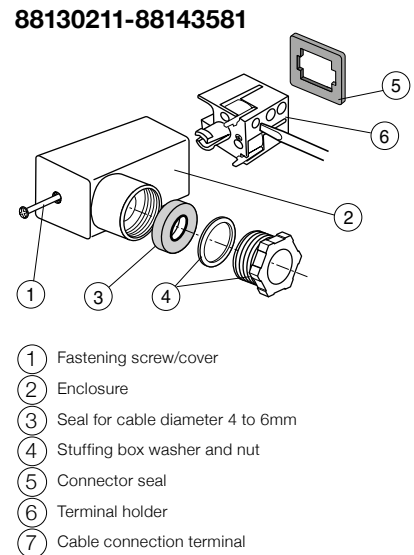
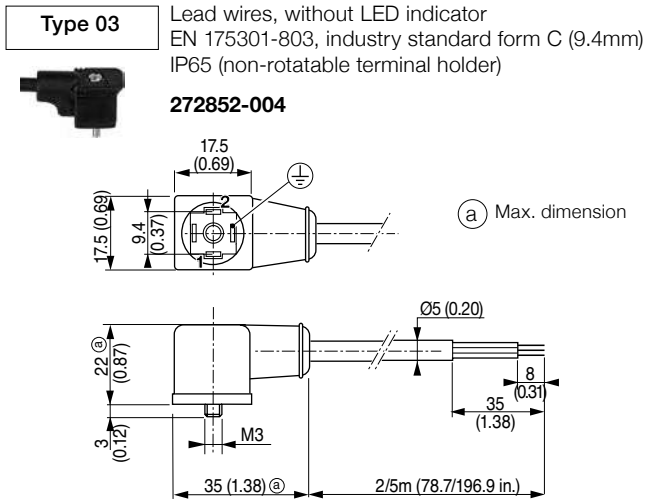
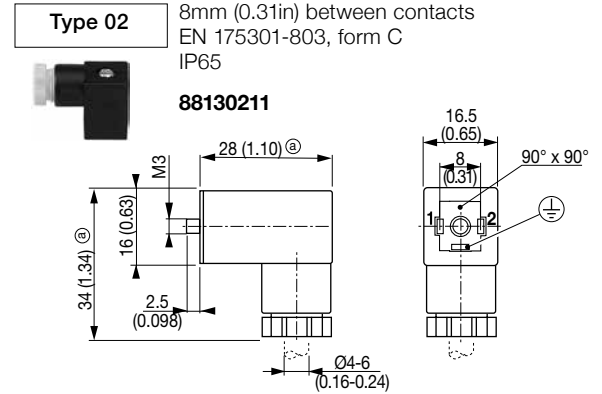
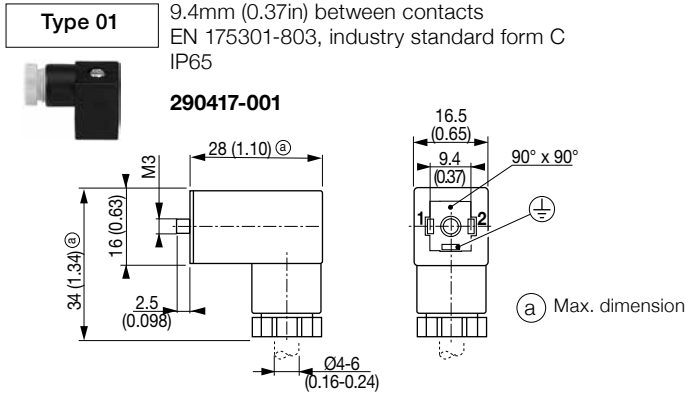

Sizes 03 and 04	
brown wire	terminal 1 (+)
blue wire	terminal 2 (-)
green/yellow wire	ground

Type	L	Weight ¹ kg	
	m (inches)	without LED indicator	with LED indicator
01-02	-	0.015	-
03	2 (78.7)	0.100	-

¹ Including seals and screws

Options

- Connectors with cable 5m (196.9in) long available on request

Installation

- The connectors can be mounted in any position without affecting operation

POWER-SAVE CONNECTORS

Once a DC-type solenoid valve is activated, only the holding current, which corresponds to 50% of the inrush voltage, is necessary to keep the valve in position. The power-save connector switches to holding voltage after approx. 70 ms (size 30) or 140 ms (size 22). The holding power is thereby reduced to a quarter of the inrush power. During power reduction, the valve's coil is piloted via PWM voltage pulses.

- The main advantages of a connector with voltage reduction are:
 - Power savings (lower current consumption)
 - Low heat development in the solenoid valve

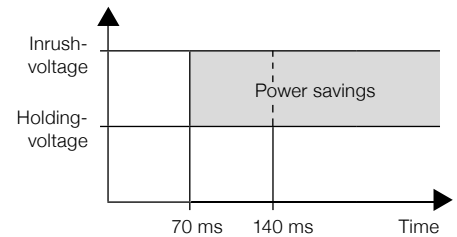

Construction	
Enclosure	PA

Electrical Characteristics		
	Size 22	Size 30
Input Voltage	12/24 VDC ± 10%	10 to 30 VDC
Output Voltage	12 VDC ± 10%	6 to 30 VDC
Power Rating	Max. 12 W	Max. 30 W
Connector	Spade plug	Spade plug
Electrical Safety	Industry standard, form B	ISO 4400/EN 175301-803, form A
Number of Contacts	2 + 1 common ground	2 + 1 common ground
Electrical Enclosure Protection	IP65	IP65
Cable Diameter	6 to 8mm (0.24in to 0.31in)	6 to 8mm (0.24in to 0.31in)
LED Green	Solenoid valve actuation	Solenoid valve actuation
LED Red	-	Overcurrent or overvoltage
Voltage Reduction	After 140ms	After 70ms
PWM Frequency	7 KHz	50 KHz

Specifications			
Description	Size	Input Voltage	Catalog Number
Power-save connector with voltage reduction	22	24 VDC ± 10%	88100934
		12 VDC ± 10%	88100944
	30	10 to 30 VDC	88100945

01037GB-2019-R01

Dimensions: mm (inches)

Size 22 11mm (0.43in) between contacts

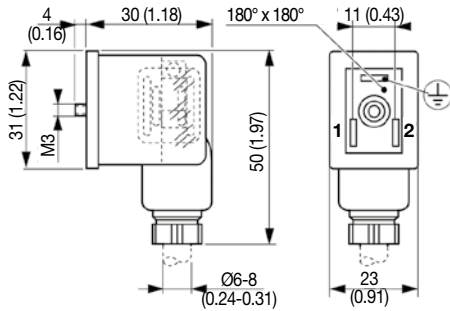

Size 33 18mm (0.71in) between contacts

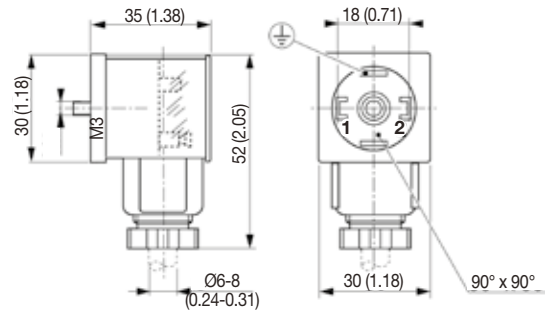

Electrical Connection

Size 22 11mm (0.43in) between contacts

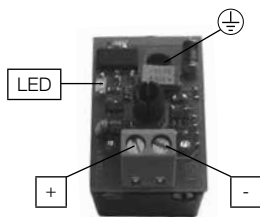

- Screw terminals: up to 1mm² cable
- + Pilot voltage + (12/24 V)
 - Pilot voltage - (GND)
 - ⊕ Ground terminal, straight through



- ① Valve voltage +
- ② Valve voltage -
- ③ Ground terminal (PE)

Size 33 18mm (0.71in) between contacts

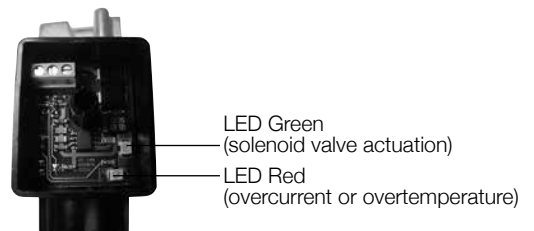

- Screw terminals: up to 1mm² cable
- + Pilot voltage + (10-30 V)
 - Pilot voltage - (GND)
 - ⊕ Ground terminal (PE)



- ① Valve voltage +
- ② Valve voltage -
- ③ Ground terminal (PE)

CONTROL DEVICE

ELECTRONIC CONTROL UNIT

- Converts analog input control signals to coil current of a proportional solenoid valve by means of pulse width modulation
- LED-Display integrated in the connector
- Adjustable UP/DOWN ramp control
- Output coil current independent of coil resistance (temperature) and supply voltage variations
- The electronic circuit is integrated in a standard housing according to DIN EN 175301-803, form A
- Parameter setting via PC interface and programming adapter or, optionally, via the switches integrated in the connector

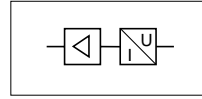

General Information	
Nominal Voltage	12/24 VDC
Maximum Current	1.2/2.5A
Housing	PA
Cover	PA
Screw	Zinc plated steel
Seals	NBR

Electrical Characteristics	
Connector	M12, 5 pins
Connector Specification	DIN EN 175301-803, form A
Electrical Safety	IEC 335
Electrical Enclosure Protection	IP65 (EN 60529)
Supply Voltage	12 V...30 VDC (incl. ripple)
Ramp	Selectable ON/OFF, adjustable between 50 ms to 5 s, Up/Down
Adjustable Switching Frequency	60 to 1500Hz

Max. Full Load Current	Input Control Signal		Ambient Temperature Range
	I_{FL} mA	U_c V	
1200/2400	0 - 10	4 - 20	-20 to 65 (-4 to 149)

Specifications				
Catalog Number: Proportional Valves for Digital Control Unit	Type ¹	Setpoint	Catalog Number	
			Control Unit	Adapter
202A001V to 202A087V 203B001V and 203B002V 60200001, 60200002, 60200004	01	0 - 10 V	X90850164500100	-
		4 - 20 mA	X90850164500200	
202A201V to 202A208V and 202A513V	02	0 - 10 V	X90850164500100	833-064154
		4 - 20 mA	X90850164500200	

¹ Refer to the dimensional drawings on the following page

Proportional Valves Suitable for Control Applications		
Description	Series	Illustration
3-port proportional valve for pressure control	602	
Posiflow/Preciflow proportional solenoid valves, Flapper proportional	202-203, 068	

01046GB-2019-R01

Dimensions: mm (inches)

Type 01 Control Unit

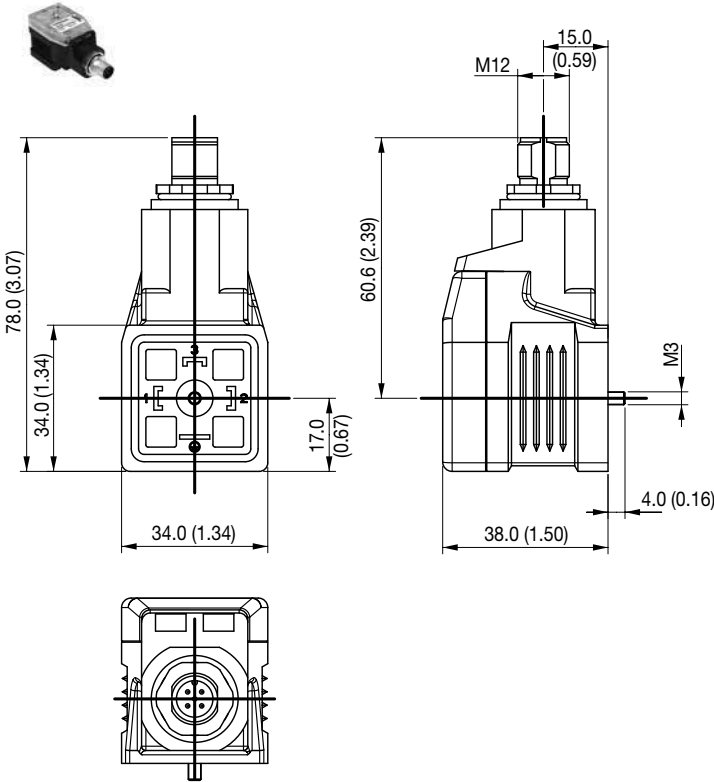

Type 02 Adapter
from form A to form B

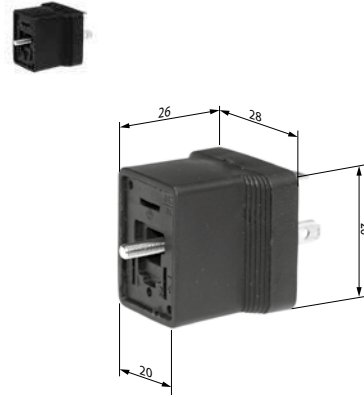

Programming Adapter



Input and Output Signals	
Pin	Supply
1	Voltage supply (see "Electrical Characteristics")
3	Analog ground 0 V (GND)
Analog signals	
2	Setpoint input (differential input) The range 0...100% corresponds to an input voltage of 0...10 V or an input current of 4...20 mA (depending on version used)
4	
Communication	
5	LIN Bus connection The parameters for the device can be set via this connection and our programming adapter

Accessories	
Description	Catalog Number
Straight M12 female connector, 5 pins, with screw terminals	88100256
Right-angle M12 female connector, 5 pins, with screw terminals	88100725
Supply cable 2m, 2 x 0.25mm ² , straight connector	88100726
Supply cable 2m, 2 x 0.25mm ² , right-angle connector	88100727
Supply cable 5m, 6 x 0.56mm ² , straight connector	88100728
Supply cable 5m, 6 x 0.56mm ² , right-angle connector	88100729
Supply cable 10m, 6 x 0.56mm ² , straight connector	88100730
Supply cable 10m, 6 x 0.56mm ² , right-angle connector	88100731
Adapter DIN EN 175301-803 from form A to form B for Type 02	833-064154
Programming adapter	X90850164500300

Installation

- The control unit can be mounted in any position without affecting operation

PINCH VALVE TUBING & GUIDE

Tubing

- Platinum-cured Bio-Medical Grade silicone tubing designed specifically for analytical and medical devices
- Suitable for a wide range sterilization techniques such as steam autoclaving, gamma radiation, and ethylene oxide
- Excellent flexibility
- No peroxide cure chlorophenyl or PCB by-products
- Meets ISO 10993 guidelines for body contact applications
- Manufactured to the principles of FDA 21 CFR 210/211 cGMPs for Pharmaceutical products
- Available in 5' and 50' lengths

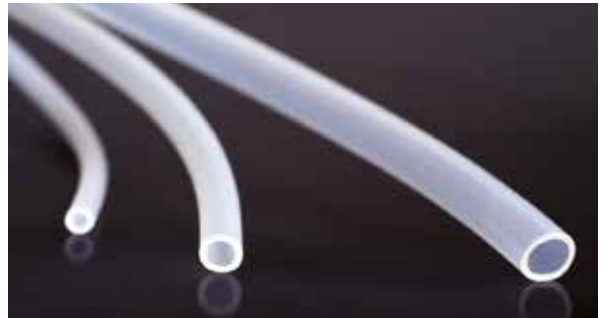

Specifications	
Tubing Material	Platinum Cured Silicone
Durometer	50 Shore A
Tensile Strength at Break	1388 psi
Elongation at Break	815%
Tear Strength	263 psi
Standards	Manufactured to the principles of FDA 21 CFR 210/211 cGMPs for Pharmaceutical products



Tubing Catalog Numbers

Tubing for 045, 284, 384 Series				
Tubing Sizes mm (inches)			Length m (ft)	Tubing Catalog Number
ID	OD	Wall		
0.762 (0.030)	1.65 (0.065)	0.444 (0.0175)	1.52 (5)	P099AU521738105
			15.2 (50)	P099AU521738150
0.794 (1/32)	2.38 (3/32)	0.794 (1/32)	1.52 (5)	P099AU521738205
			15.2 (50)	P099AU521738250
1.59 (1/16)	3.17 (1/8)	0.794 (1/32)	1.52 (5)	P099AU521738305
			15.2 (50)	P099AU521738350
1.59 (1/16)	4.76 (3/16)	1.59 (1/16)	1.52 (5)	P099AU521738405
			15.2 (50)	P099AU521738450
3.17 (1/8)	6.35 (1/4)	1.59 (1/16)	1.52 (5)	P099AU521738505
			15.2 (50)	P099AU521738550
4.76 (3/16)	7.94 (5/16)	1.59 (1/16)	1.52 (5)	P099AU521738605
			15.2 (50)	P099AU521738650
6.35 (1/4)	9.52 (3/8)	1.59 (1/16)	1.52 (5)	P099AU521738705
			15.2 (50)	P099AU521738750

Tubing Guide

ASCO offers plastic tubing guides that slide easily onto the valve body of the pinch valves to retain small OD tubing in the pinch valve body.

Dimensions: mm (inches)

Tubing Guide

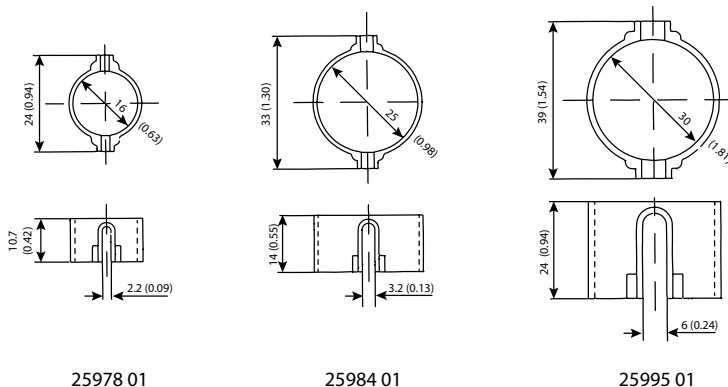

Tubing Guide Catalog Number	Max OD of Tubing	Valve Series
2597801	2.2 (0.09)	SCH284A001
		SCH284A002
		SCH284A003
		SCH284A004
		SCH284A009
		SCH284A010
		SCH284A011
		SCH284A012
		SCH384A001
		SCH384A002
		SCH384A003
		SCH384A004
2598401	3.2 (0.13)	SCH284A005
		SCH284A013
		SCH394A005
2599501	6 (0.24)	SCH284B006
		SCH284B007
		SCH284B014
		SCH284B015
		SCH384B006
		SCH384B007
		SCH384B007

01088GB-2019-R01

SOLENOID VALVES INFORMATION & TERMINOLOGY

Solenoid Valves

A solenoid valve is a combination of two functional units:

1. A solenoid operator essentially consisting of a coil, core, core tube, shading coil and spring(s).
2. A valve body containing orifices in which a disc, diaphragm or piston, etc. is positioned according to the type of technology used.

The valve is opened or closed by movement of the magnetic core which is drawn into a solenoid when the coil is energized.

Solenoid Valve Terminology

(Fig. 1)

Coil

Electrical part of the valve consisting of a spool wound with insulated copper wire creating a magnetic flux when energized.

The coil is held in place on the tube with a retaining clip.

Core

Soft-magnetic component moved by magnetic forces (flux generated by the coil).

Core spring

Spring which keeps the core in fixed position when the coil is de-energized.

Core tube

Stainless steel tube closed at one end, installed to improve the magnetic flux of the

solenoid coil upon energization.

Cover

Cover mounted on the valve body and incorporating a number of orifices.

Diaphragm

Seal-tight diaphragm isolating the fluid from the control system.

Disc

Sealing material on the core or disc-holder which shuts off the seat orifice.

Manual operator

Manual operation of the lever to open or close the orifices.

Manual operator spring

Drawback spring ensuring return of the pulse control device to its initial position.

Orifices

Orifices for fluid transit.

Plugnut

Stationary core pressed in the closed end of the core tube, installed to improve the magnetic flux of the solenoid coil upon energization.

Retainer clip

Clip anchoring the coil to the yoke.

Rocker

Moving part serving to open and close the orifices for the passage of fluid.

Valve seat

Specially formed border of the main valve.

Solenoid enclosure

Metal housing around the coil for electrical and mechanical protection, as well as protection against ingress of water or dust.

Valve body

Main part of the valve with all ports and main seats.

Types of Solenoid Valves

2/2-3/2 Solenoid Valves with Fluid Isolation

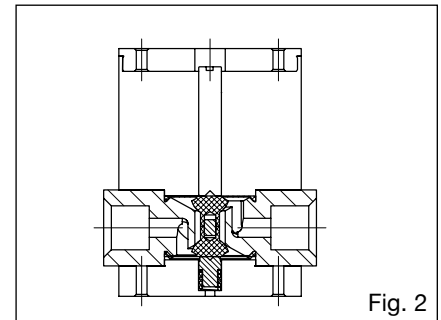

Fig. 2

Diaphragm (Fig. 2)

Diaphragm type solenoid valves are compact, have a very extended service life and a very small internal volume. They are ideal for handling aggressive fluids. The valve body is in stainless steel or plastic (PVDF/PP), with a diaphragm in VMQ (silicone), FKM or PTFE. Low power rating.

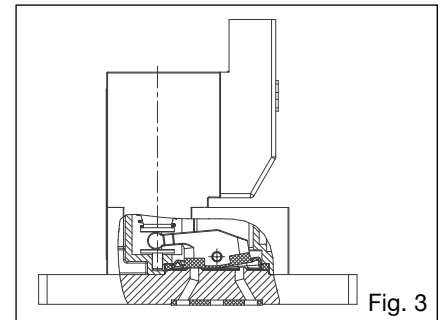

Fig. 3

Rocker (Fig. 3)

Rocker type solenoid valves are compact, and designed to incorporate a hermetic seal between fluid and control system. These valves are ideal for handling aggressive fluids, or where a maximum level of fluid purity is required. Low power rating and fast response times.

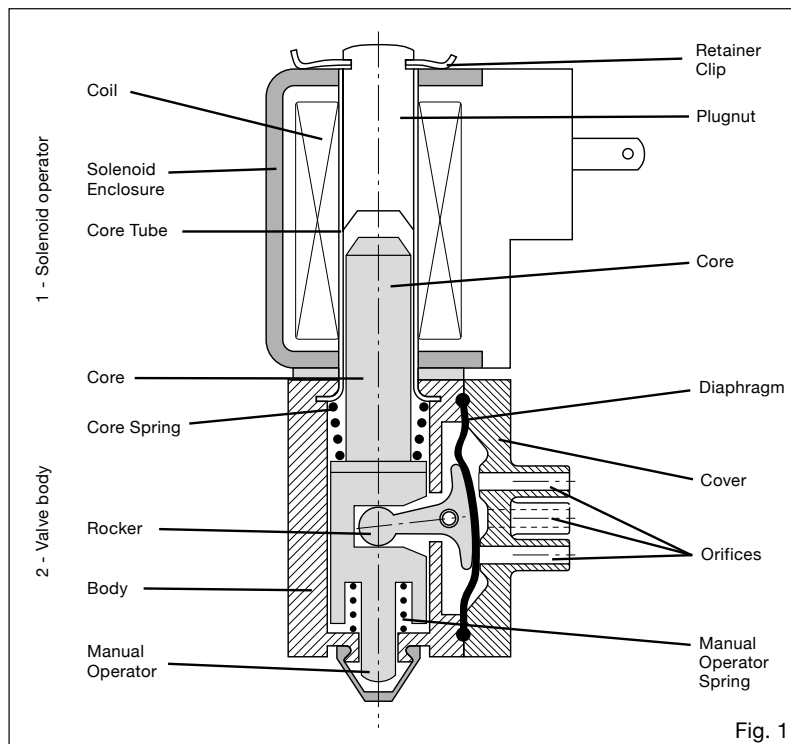
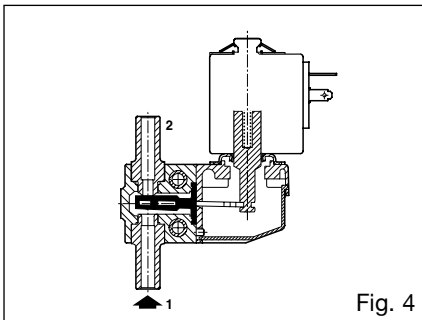

Fig. 1

Visit our website at emerson.com

Availability, design and specifications are subject to change without notice. All rights reserved.

Lever (Fig. 4)



Lever type solenoid valves are designed for high differential pressures and flow rates. Heat dissipation for the electromagnetic part is optimised by separating the control system from the valve itself. These valves are ideally suited for high ambient temperatures. Threaded or spigot connections.

Bellows (Fig. 5)

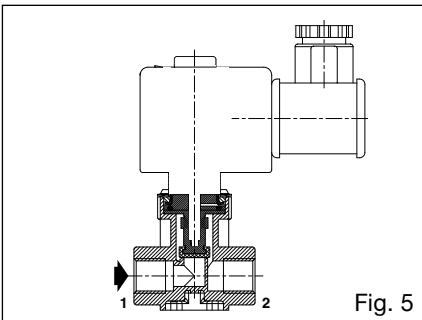

Bellows solenoid valves ensure exceptional operating reliability under severe service conditions and extended life service. A body in PEEK or stainless steel, bellows in PTFE and disc in FFKM make these valves suitable for handling highly corrosive fluids at substantial flow rates. Threaded connections.

Pinch (Fig. 6)

Pinch type solenoid valves provide full bore flow (no internal volume) and extended service life. This is achieved by means of the pinch device, designed specially to operate smoothly with a balanced load. No contamination of the fluid is possible, and operation of the valve is silent. Bidirectional fluid flow.

Direct operated 2/2 solenoid valves

The core is mechanically connected to the disc and opens or closes the orifice, depending on whether the solenoid coil is energized or de-energized.

Core-disc valve construction (Fig. 7)

Operation is not dependent upon line pressure or rate of flow (zero or maximum rated pressure). These valves are generally available in 2/2 NC/NO and 3/2 NC/NO/U versions.

NC = Normally Closed

NO = Normally Open

U = Universal

Pressures

Maximum operating pressure differential – MOPD

The maximum operating pressure differential (DP) is the pressure the solenoid operator has to overcome to open (NC function) or

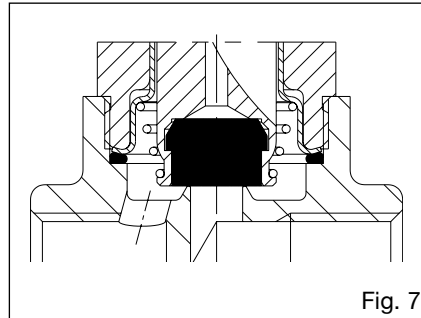

close (NO function) a solenoid valve.

The maximum operating pressure differential refers to the maximum difference in pressure between the inlet and outlet.

If the pressure at the outlet is zero, the supply pressure is to be regarded as the maximum operating pressure differential. In this case, in order to prevent coil burnout, the pressure at the inlet must not exceed the maximum operating pressure differential specified for each valve.

The maximum operating pressure differential may vary according to the fluid or type of power used (AC valves usually have higher pressure ratings than DC valves).

Minimum operating pressure differential

Minimum operating pressure differential (bar) is that which is required to open the valve and keep it open. The valve will start to close below the minimum operating differential pressure.

Maximum allowable pressure

(according to EN 764)

The maximum allowable pressure is the maximum line or system pressure to which the valve may be subjected in normal service and at a given temperature, generally, ambient temperature, without causing damage.

Temperatures

Normal ambient temperature

The normal ambient temperature is assumed to be in accordance with standard conditions as specified in ISO 554

ambient temperature : 20 °C (68 °F)

ambient pressure : 1013 mbar
(14.69 psi)

relative humidity : 65%

Maximum ambient temperature

The maximum ambient temperature is based on test conditions to determine safe limits for coil insulation. The temperature is determined under continuously energized conditions and

with maximum fluid temperatures (as listed) existing in the valve.

Minimum ambient temperature

The minimum ambient temperature of a valve is greatly affected by application and construction.

Damage may occur when liquids solidify above the specified minimum temperature. Be sure to observe minimum and maximum limits.

Maximum fluid temperature

The maximum fluid temperature listed is valid for an ambient temperature of 20 °C (68 °F) and 100% RD (Relative Duty Time).

Viscosity

Viscosity is the resistance of a fluid to flow, due to internal friction. Viscosity affects the flow rate of a valve considerably and the flow factor is reduced when viscous fluids are to pass through the valve.

There are two types of viscosity:

- dynamic viscosity, expressed in Pa.s (Pascal seconds) or Poises
- kinematic viscosity, which is the ratio between dynamic viscosity and density of the fluid

Kinematic viscosity is expressed in mm²/s or cStokes; in this catalog only kinematic viscosity is considered.

VALVE CONSTRUCTION MATERIALS

Rubbers

CR (chloroprene)

Principally used in refrigeration systems (Freon 22) as an external seal. Neoprene is also utilized for oxygen service valves. Suitable for alcohol, mild acids, water, air, ammonia, argon gas and other gases.

It has a temperature range of -20 °C (-4 °F) to 90 °C (194 °F).

CSM (chlorosulfonated polyethylene)

Used to handle strong oxidizing fluids, edible liquids, and many other common chemicals, etc. Not recommended for aromatic or chlorinated hydrocarbons. It has a temperature range of -40 °C (-40 °F) to 120 °C (248 °F).

Hypalon® is an example for CSM; it is part of the family of elastomers.

(Hypalon® is a registered trademark of Dupont Performance Elastomers)

EPDM (ethylene-propylene)

Suitable for temperatures above the NBR range (i.e. excellent for phosphate ester type fluids; not recommended for use with petroleum base fluids), except ethylene-propylene has a somewhat higher temperature range than NBR. Useful as "O" ring gaskets on steam valves due to low compression set.

Ethylene-propylene is generally suitable for most photographic solutions as well as numerous chemical solutions.

Ethylene-propylene is selected for applications which have a wider temperature range than the NBR temperature range, such as handling hot water and steam. Ethylene-propylene has an extremely wide range of fluid compatibility but has the distinct disadvantage that it cannot be used with petroleum-based fluids or contaminated fluids (such as lubricated air). It has a temperature range of -20 °C (-4 °F) to 180 °C (356 °F).

FFKM (perfluoroelastomer)

Elastomer used in the manufacture of joints and seals, combining resistance to aggressive chemical environments, swelling and high temperatures. Particularly suitable for pharmaceutical applications requiring extreme conditions of cleanliness.

Kalrez® is an example for FFKM; it is part of the family of elastomers.

(Kalrez® is a registered trademark of Dupont Performance Elastomers)

FKM (fluoroelastomer)

Suitable for temperatures above the NBR range. Excellent resistance to many petroleum oils, gasoline, dry-cleaning fluids and jet fuels. Not compatible for ketones, halogenated hydrocarbons and freons.

FKM is a fluorocarbon elastomer which was primarily developed for handling hydrocarbons such as jet fuels, gasolines, solvent, etc., which normally caused detrimental swelling to NBR. FKM has a high temperature range similar to ethylene-propylene but has the advantage of being somewhat more resistant to "dry heat". FKM has a rather wide range of chemical compatibility. It has a temperature range of -40 °C (-40 °F) to 190 °C (374 °F).

Viton® is an example for FKM; it is part of the family of elastomers.

(Viton® is a registered trademark of Dupont Performance Elastomers)

FVMQ (fluorosilicone)

A silicone with a trifluoropropyl group on each siloxane unit. Good resistance to heat and most solvents. Good low temperature characteristics.

NBR (nitrile)

Standard compound for service in petroleum oils, air, water, mild acids, acetylene, kerosene, lime solutions, liquified petroleum gases and turpentines. Not recommended for highly aromatic gasolines or acids.

NBR is commonly referred to as a nitrile rubber and is standard synthetic elastomer for accomplishing resilient-type seating or sealing in most valves. It has excellent compatibility for most air, water and light oil applications. It has a temperature range of -20 °C (-4 °F) to +90 °C (194 °F).

Buna® is an example for NBR; it is part of the family of elastomers.

(Buna® is a registered trademark of DuPont de Nemours and Company or its affiliates)

SBR (styrene butadiene)

SBR is a polymer used in the manufacture of seals. Good resistance to swelling in acids, non-organic and organic bases, alcohols and water.

UR (urethane)

Used for water, air at normal ambient temperatures, alcohol, non-aromatic compounds, ether, edible fats and oils and hydraulic fluids. Its principal assets are high strength and excellent abrasion resistance. It is not recommended for ketones and strong oxidizing agents. It has a temperature range of -30 °C (-22 °F) to 40 °C (104 °F).

VMQ (silicone)

Known as the only elastomer which, under certain conditions, can be utilized for both high and low temperature, which is its principal use. Also handles hydrogen peroxide and some acids. Not good for steam; poor disc life. Fluorosilicone compounds are noted to have better fuel resistance.

Note:

Temperature limitations for elastomers are somewhat dependent on their specific functional usage in a valve.

Obviously, a diaphragm which stiffens at low temperature is objectionable while an "O" ring gasket of similar material which stiffens at low temperature may still be performing its sealing function.

Generally, temperatures down to -20 °C (-4 °F) can be considered tolerable and special elastomers such as silicone and low temperature NBR must be selected for use below this temperature.

These elastomers can extend the lower limit to approximately -40 °C (-40 °F) depending on specific usage. The upper limit for elastomers is generally around 100 °C (212 °F), except FKM, EPDM and VMQ which can, on specific applications, be utilized up to 190 °C (374 °F).

PTFE (see following page) is a commonly used gasket or disc material not considered an elastomer. This unique chemical-resistant material can be used from -270 °C (-454 °F) to 250 °C (482 °F) with proper design limitations.

Plastics

PA (polyamide)

Polyamide resins are known to be very durable and also resistant to many chemicals. A heat resistant type polyamide is always used in ASCO valves.

PARA (polyarylamide)

Aromatic polyamide in which at least one monomer contains a benzene ring, giving it improved mechanical, thermal and chemical resistance.

Ixef® is an example for polyarylamide; it is part of the family of thermoplastics.

(Ixef® is a registered trademark of Solvay S.A.)

PC (polycarbonate)

Good with polar solvents, salt solutions and water applications. Not recommended for non-polar solvents. A polycarbonate type thermoplastic known for having high impact strength and good resistance to inorganic acids and aliphatic hydrocarbons. Not suitable for use with air containing phosphate esters (found in synthetic oils).

PE (polyethylene)

A family of plastics varying from low melting point to high heat distortion temperature; and from flexible to rigid. Although somewhat soft, they offer good electrical, chemical and moisture resistance and physical properties.

PEEK (polyetheretherketone)

High performance thermoplastic with exceptional resistance to a wide range of chemical environments and high temperatures.

PEI (polyetherimide)

This resin has good heat deflection characteristics. Good chemical resistance to non-oxidizing acids and polar solvents. Questionable usage on alkaline solutions.

Ultem® is an example for PEI; it is part of the family of plastics.

(Ultem® is a registered trademark of General Electric Company)

POM (polyacetal or polyoxymethylene)

Acetal resin type thermoplastics are extremely rigid but not brittle. They provide good toughness, tensile strength, stiffness and long life. They are non-toxic and resistant to most solvents.

Delrin® is an example for polyacetal; it is part of the family of plastics.

(Delrin® is a registered trademark of DuPont de Nemours and Company or its affiliates)

PP (polypropylene)

A thermoplastic known to have excellent resistance to inorganic salts, mineral acids and gases. It offers good resistance to photographic solutions and is one of the few plastics that has the ability to withstand steam sterilization.

PPS (polyphenylene sulfide)

This resin has outstanding chemical resistance and no known solvents below 200 °C (392 °F) It has low friction, good wear resistance and high tensile strength.

Ryton® is an example for PPS; it is part of the family of plastics.

(Ryton® is a registered trademark of Chevron Phillips Chemical Company)

PSU (polysulfone)

Known as one of the most heat resistant of the thermoplastics. It has excellent chemical resistance when used for inorganic acids, alkalis and aliphatic hydrocarbons.

PTFE (polytetrafluoroethylene)

A fluorocarbon resin known to be suitable for disc material where all other synthetic materials have failed. Teflon® is not easily fabricated and is known to have objectionable "cold flow" characteristics.

Teflon® is an example for PTFE; it is part of the family of plastics.

(Teflon® is a registered trademark of DuPont de Nemours and Company or its affiliates)

PTFE Reinforced

PTFE reinforced is a form of PTFE having fillers which have been added for improved mechanical properties. PTFE and TPE with fillers are considered more of a plastic than a resilient-type material. They are virtually unattacked by any fluid. Their temperature usage ranges from discs for cryogenic valves to discs for steam valves. The "cold flow" characteristics may contribute to leakage particularly on gases. They have a temperature range of -270 °C (-454 °F) to 250 °C (482 °F).

Rulon® is an example for reinforced PTFE, it is part of the family of plastics.

(Rulon® is a registered trademark of Saint Gobain Performance Plastics Corporation)

PUR (polyurethane)

Polyurethane is a multipurpose, robust product. It has good adhesion to a variety of substrates, providing resistance to humidity and impact strength.

PVC (polyvinyl chloride)

Known for its chemical inertness but has somewhat less temperature resistance than most other plastics. PVC has excellent resistance to strong alkalis, mineral acids, salts and many chemicals corrosive to conventional materials.

PVDF (polyvinylidene fluoride)

Polymer resistant to atmospheric agents and the majority of chemical products at ambient temperature. High purity PVDF compounds are particularly recommended for medical applications.

TPE (thermoplastic polyester elastomer)

Used in some diaphragm applications. HYT elastomers show high strength in tension, compression and flex. They are superior to polyurethane rubbers in load-bearing capacity.

Hytrel® (HYT) is an example for a polyester elastomer, it is part of the family of plastics.

(Hytrel® is a registered trademark of DuPont)

Metals

Ag (silver)

Shading coil material for stainless steel valves.

Al (aluminum)

Shading coil material for special fluids or for making washers, etc. Die cast aluminum is generally used for bodies for low pressure gas valves and can only be used with "water free" systems. It can be noted that die cast aluminum is successfully used in oil and gasoline applications.

Cu (copper)

Primarily used for shading coil.

Cu Sn (bronze)

Casting bronze is used for body forging. Good sealing and casting properties, resistant to abrasion.

Cu Zn Pb (brass)

Forging brass is used in our body forgings. Forging brass has a composition of 59% copper, 2% lead and 39% zinc.

Fe Cr Ni (stainless steel AISI 303 or 304)

One of the most widely used steels containing 18% chromium and 8% nickel. Used for valve bodies, springs and internal parts. Known as stainless steel type 303 or 304.

Fe Cr Ni Mo (stainless steel AISI 316)

Alloy containing approx 17% chromium, 12% nickel and 2% molybdenum. Highly corrosion resistant.

Fe Cr Ni Mo (stainless AISI 316L)

Alloy containing 16 to 18% chromium, 11 to 14% nickel and 2.5 to 3% molybdenum. Valve bodies made from this material provide excellent resistance to particularly aggressive fluids.

Ni Fe (nickel iron)

Core material for low temperature fluids (below -100 °C) particularly for "long stroke" solenoids.

Pb (lead)

Used for lead-clad copper gaskets.

Zamak

Zinc alloy containing approx. 4% aluminum, 0.04% magnesium and 1% copper. Used, for example, for the bodies of air treatment equipment.

CHEMICAL RESISTANCE GUIDE

GENERAL

Our valves are available to control most acids, alcohol, bases, solvents and corrosive gases and liquids. Modified or special designs are sometimes required depending upon the fluid and application.

Corrosion occurs either as a chemical or electro-chemical reaction. Therefore, consideration must be given to both the

galvanic and electromotive force series, as well as to pressure, temperature and other factors that might be involved in the application.

This guide provides information on most common corrosive and non-corrosive, unmixed gases and liquids.

Mixtures of different fluids and their

temperatures are not included in this table. It's the user's responsibility to ensure the chemical and physical compatibility of the body and other materials with the fluids used.

For applications where abnormal conditions exist and for other types of valves, operations and fluids, contact us with full details of the operating conditions.

Fluids	body materials											other materials in contact with fluid											
	Steel	Stainless Steel AISI 303/304	Stainless Steel AISI 316	Stainless Steel AISI 316L	Aluminum	Bronze	Cast Iron	Brass	PA	PEEK	PPS	Silver	Copper	CR	EPDM	FFKM	FKM	NBR	UR	PET	POM	PTFE	TPE
Acetaldehyde	↘	↑	↑	↑	↘	↑	↑	↘	↘	↑	↑	↑	↘	↘	↑	↑	↘	↘	↘	↘	↘	↑	↘
Acetic acid	↘	→	→	→	↘	↘	↘	↘	↘	↑	↑	↑	↘	↘	→	→	↘	↘	↘	↘	↘	↑	↘
Acetic anhydride	↘	→	→	→	↘	↘	↘	↘	↘	↑	↑	↑	↘	↘	→	→	↘	↘	↘	↘	↘	↑	↘
Acetone	↑	↑	↑	↑	↑	↑	↑	↘	↘	↑	↑	↑	↑	↑	↑	↓	↓	↓	↓	→	→	↑	↓
Acetonitrile	→	↑	↑	↑	↑	-	↑	-	-	↑	-	-	-	↑	→	↑	↓	↓	↓	→	-	↑	→
Acetophenone	-	↑	↑	↑	→	-	↑	↑	↑	-	→	-	-	↓	↑	↑	↓	↓	↓	→	-	↑	-
Acetyl chloride	↑	→	↑	↑	↓	↑	→	→	↘	-	↑	-	↑	↓	↘	↑	↑	↓	↓	↓	↓	↑	↓
Acetylene	↑	↑	↑	↑	↑	↘	↑	→	↘	↑	↘	↓	↓	↘	↑	↑	↓	→	↓	↓	↑	↑	↑
Air (lubricated)	↑	↑	↑	↑	↑	↑	↑	↑	↑	↑	↑	-	-	↑	↘	↑	↑	↑	↑	↑	↑	↑	↑
Air (unlubricated, dry)	↑	↑	↑	↑	↑	↑	↑	↑	↑	↑	↑	-	-	↑	↑	↑	↑	↑	↑	↑	↑	↑	↑
Alcohol ethyl (ethanol)	↑	↑	↑	↑	→	↑	↑	↓	↑	-	-	↑	→	↑	↑	↑	→	↑	↓	↑	↑	↑	↑
Alcohol methyl (methanol)	↑	↑	↑	↑	→	↑	↑	↓	↑	-	↑	↑	→	↑	↑	↑	↓	↑	↓	↑	↑	↑	↑
Aluminum sulfate	↘	→	↑	↑	↑	↘	↓	↘	↘	↑	↑	→	→	↑	↑	↑	↑	→	↓	↑	↑	↑	→
Ammonia, anhydrous	↑	↑	↑	↑	↘	→	→	↘	↘	↑	↘	↘	↓	↑	↑	→	↓	→	↓	↘	↘	↑	↘
Ammonia, aqueous	↑	→	↑	↑	↓	↘	→	↓	↘	-	↘	↘	↘	→	↑	→	→	↘	↓	↑	↓	↑	-
Ammonia, water	↑	→	↑	↑	↓	↘	→	↓	↘	-	↘	↘	↘	→	↑	-	→	↘	↓	↑	↓	↑	-
Ammonium hydroxyde	↘	→	→	→	↘	↘	↘	↓	↘	↑	→	↓	↓	→	↑	→	→	↘	↓	↑	→	↑	→
Amyl acetate	↘	→	→	→	↘	↑	→	→	↑	↑	-	↑	↓	↑	↑	↓	↓	↓	→	↑	↑	↑	↘
Aniline	↘	→	↑	↑	↘	↘	→	→	↘	↑	↑	↑	↓	↓	↑	→	↓	↓	↓	↑	↑	↑	↘
Argon	↑	↑	↑	↑	↑	→	→	↑	↑	↑	↑	↑	↑	↓	↑	↑	↑	↑	↑	-	-	↑	↑
Barium chloride	↘	→	↑	↑	↓	↑	↘	↑	↘	↑	↑	-	→	↑	↑	↑	↑	↑	↑	↑	↑	↑	→
Barium hydroxide	↘	→	↑	↑	↓	↘	↘	→	↘	-	↑	↑	↓	↑	↑	↑	↑	↑	→	↑	↓	↑	→
Benzaldehyde	↑	↑	↑	↑	↑	↑	↑	→	→	↑	→	↓	→	↓	→	↑	↓	↓	↓	↓	↑	↑	→
Benzene pure	→	↑	↑	↑	→	↑	→	→	↘	↑	→	↑	→	↓	↓	↑	↑	↓	↓	→	↑	↑	→
Benzene sulfonic acid	→	↑	↑	↑	↓	→	↓	→	↘	↓	→	↑	↘	→	↘	↑	↑	↘	↓	→	↘	↑	→
Borax	→	↑	↑	↑	↘	↑	↑	→	↘	↑	↑	-	→	→	↑	↑	↑	→	↑	↑	↑	↑	↑
Bromine	↘	↓	↘	↘	↓	↓	↓	-	↘	↓	↓	→	↘	↓	↓	↑	↑	↓	↓	→	↓	↑	↓
Butadiene	↑	↑	↑	↑	↑	↑	↑	↑	↘	-	↑	-	↘	→	↘	↑	↑	↓	↓	↓	↑	↑	↓
Butane	↘	↑	↑	↑	→	→	→	↑	↑	↑	↑	-	↘	↑	↓	↑	↑	↑	↘	→	↑	↑	→
Butanol (aqueous, butyl alcohol)	↑	↑	↑	↑	→	↑	→	↑	↑	-	↑	→	→	↑	→	↑	↑	↑	↓	→	↑	↑	→
Butylene	↘	↑	↑	↑	↑	→	↑	↘	↑	-	↑	-	↓	↘	↓	↑	↑	→	↓	→	↑	↑	→
Butyl acetate	↑	↑	↑	↑	↑	↑	↑	→	↑	↑	↑	→	↑	↓	→	↑	↓	↓	↓	→	→	↑	↘
Butylamine	↑	↑	↑	↑	↑	→	↑	-	↑	-	↓	-	-	↓	↓	↑	↓	↓	↓	→	↓	↑	↓
Butyl ether	↑	↑	↑	↑	↑	-	↑	-	↓	↑	↑	-	-	↘	↘	↑	↓	→	→	↓	↓	↑	↓
Calcium chloride	↘	→	→	→	↓	→	↓	-	↘	↑	↑	↑	→	↑	↑	↑	↑	↑	↑	↑	↓	↑	↑
Calcium sulfate	→	↑	↑	↑	↓	→	↑	↓	↘	↑	↑	↑	→	↑	↑	↑	↑	↑	↑	↑	↓	↑	-
Carbon dioxide (wet/dry)	↑	↑	↑	↑	↑	→	↑	↓	↑	-	↑	↑	↑	→	→	↑	↑	↑	↑	↑	↑	↑	↘
Carbon tetrachloride	↑	↘	↘	↘	↓	↑	↓	↑	↘	↑	→	→	↘	↓	↓	↑	↑	↘	↓	→	↑	↑	↓
Caustic soda	→	↑	↑	↑	↓	→	→	→	↑	↑	→	-	-	→	↑	↑	→	↘	→	-	↑	↑	→
Cellosolve	↑	→	↑	↑	→	-	→	↑	↑	-	↑	-	-	↓	→	↑	↘	↓	↓	↑	↑	↑	↓

Please note that the chemical resistance may be influenced by many factors, such as temperature, concentration, etc. This data is for reference only.

Fluids	body materials												other materials in contact with fluid										
	Steel	Stainless Steel AISI 303/304	Stainless Steel AISI 316	Stainless Steel AISI 316L	Aluminum	Bronze	Cast Iron	Brass	PA	PEEK	PPS	Silver	Copper	CR	EPDM	FFKM	FKM	NBR	UR	PET	POM	PTFE	TPE
Chlorobenzene	→	↓	↑	↑	↓	↑	↓	↑	↓	↑	↑	↓	↓	↓	↓	↑	↑	↓	↓	↓	↓	↑	↓
Chloroform	↓	↑	↑	↑	↓	↑	↓	↑	↑	↑	↑	↑	↓	↓	↓	↑	↑	↓	↓	↓	↓	↑	↓
Chlorosulfonic acid	↓	↓	↓	↓	↓	↓	↓	↓	↓	↓	↓	-	↓	↓	↓	↑	↓	↓	↓	↓	↓	↑	↓
Chlorine (wet)	↓	↓	↓	↓	↓	↓	↓	↓	↓	↓	↓	-	-	↓	↓	↑	↑	↓	↓	↓	↓	↑	↓
Chromic acid (25%)	↓	↓	↑	↑	↓	↓	↓	↓	↓	↓	↓	↓	↓	↓	↑	↑	↑	↓	↓	↓	↓	↑	↓
Chromic acid, concentrated	↓	↓	↓	↓	↓	↓	↓	↓	↓	↓	↓	-	↓	↓	↑	↑	↑	↓	↓	↓	↓	↑	↓
City gas	-	↑	↑	↑	-	-	-	↑	-	-	-	-	↓	↓	↓	↑	↑	↑	↓	-	-	↑	-
Coffee	↓	↑	↑	↑	↑	↑	↓	-	↑	-	-	-	↑	↑	↑	↑	↑	↓	↑	↑	↑	↑	-
Coke oven gas	↑	↑	↑	↑	-	↓	↑	↓	-	-	-	↑	↑	↓	↓	↑	↑	↓	↓	-	-	↑	-
Detergent	→	↑	↑	↑	↑	↑	↓	↑	-	↑	-	-	↓	↑	↑	↑	↑	↑	↓	↑	↑	↑	↓
Diesel fuel	↑	↑	↑	↑	↑	↑	↑	↑	-	↑	↑	↑	↑	↓	↓	↑	↑	↑	↓	↓	↑	↑	↓
Dimethyl formamide	→	↑	↑	↑	↑	↓	↓	↑	↑	↓	-	↑	↓	↓	↓	↑	↓	↓	↑	↑	↓	↑	↓
Dimethyl phthalate	↑	↑	↑	↑	↑	-	↑	↑	-	↑	-	-	↓	↓	↑	↓	↓	-	↑	-	↑	↑	↑
Ethylene chloride	↑	↓	↑	↑	↓	↑	↓	↑	↑	↓	↑	↓	↓	↓	↓	↓	↓	↓	↓	↓	↑	↑	↓
Ethylene diamine	→	↑	↑	↑	↑	↑	↓	↑	-	↑	-	↓	↓	↓	↓	↓	↓	↓	↓	↓	↑	↑	-
Ethylene dichloride	↑	↓	↓	↓	↑	↑	↑	↑	↑	↓	↑	↑	↓	↓	↓	↓	↓	↓	↓	↓	↑	↑	↓
Ethylene glycol	→	↓	↑	↑	↓	↑	↓	↑	↑	↑	↑	↑	↑	↑	↑	↑	↑	↑	↑	↑	↑	↑	↑
Ethylene oxide	→	↑	↑	↑	↓	↑	↓	↑	↓	-	↓	↓	↓	↓	↓	↑	↓	↓	↓	↓	↑	↑	↑
Ferric chloride	↓	↓	↓	↓	↓	↓	↓	↑	↓	↑	↓	↓	↓	↓	↑	↑	↑	↑	↑	↑	↓	↑	↑
Ferrous chloride	↓	↓	↓	↓	↓	↓	↓	↓	↓	↑	↑	↓	↓	↓	↑	↑	↑	↑	-	↑	↓	↑	↑
Formaldehyde	→	↓	↑	↑	↓	↓	↓	↑	↓	↓	↑	↓	↓	↓	↑	↑	↓	↓	↓	↑	↑	↑	↓
Formic acid	↓	↓	↑	↑	↓	↓	↓	↓	↓	↓	-	↓	↓	↓	↑	↑	↓	↓	↓	↑	↓	↑	↓
Freon 11	→	↑	↑	↑	↓	↑	↓	↓	↓	↑	↑	↑	↓	↓	↓	↓	↓	↓	↓	↑	↑	↑	↑
Freon F-12	→	↑	↑	↑	↓	↑	↓	↓	↓	↑	↑	↑	↓	↓	↓	↓	↓	↓	↓	↑	↑	↑	↑
Freon 22	→	↑	↑	↑	↓	-	↓	↑	↑	↑	↑	↑	↓	↓	↓	↓	↓	↓	↓	↓	↑	↑	↓
Freon T WD602	→	↑	↑	↑	↓	-	-	↑	↑	-	↑	-	↑	↓	↓	↓	↓	↓	↓	-	-	↑	-
Fuel oil	↑	↑	↑	↑	↑	↑	↓	↑	-	↑	↑	↓	↓	↓	↓	↑	↑	↑	↓	↑	↓	↑	↓
Fuel oil #6	↑	↑	↑	↑	↓	↑	↑	↑	-	↑	-	↓	↓	↓	↓	↑	↑	↓	↓	-	↓	↑	↑
Fuel ASTM Ref Fuel A	↑	↑	↑	↑	↓	↑	↑	↑	-	↑	-	↓	↓	↓	-	↑	↑	↑	↑	-	↓	↑	↑
Fuel ASTM Ref Fuel B	↑	↑	↑	↑	↓	↑	↑	↑	-	↑	-	↓	↓	↓	-	↑	↑	↑	↓	-	↓	↑	↑
Fuel ASTM Ref Fuel C	↑	↑	↑	↑	↓	↑	↑	↑	-	↑	-	↓	↓	↓	-	↑	↑	↑	↓	-	↓	↑	↑
Fuel ASTM #1 Oil	↑	↑	↑	↑	↓	↑	↑	↑	-	↑	-	-	↑	↓	-	↑	↑	↑	↑	-	↓	↑	↑
Fuel ASTM #2 Oil	↑	↑	↑	↑	↓	↑	↑	↑	-	↑	-	-	↓	↓	-	↑	↑	↑	↑	-	↓	↑	↑
Fuel ASTM #3 Oil	↑	↑	↑	↑	↓	↑	↑	↑	-	↑	-	-	↓	↓	-	↑	↑	↑	↑	-	↓	↑	↑
Fuel ASTM #4-5 Oil	↑	↑	↑	↑	↓	↑	↑	↑	-	↑	-	-	↓	↓	-	↑	↑	↑	↓	-	↓	↑	↑
Furan	-	↑	↑	↑	↑	-	↑	-	-	-	↑	-	-	↓	↓	↑	↓	↓	-	↓	↓	↑	-
Furfural	↑	↑	↑	↑	↑	↑	↓	↓	-	↑	↓	↓	↓	↓	↓	↓	↓	↓	↓	↓	↓	↑	↓
Gasoline (petrol)	↑	↑	↑	↑	-	↑	↑	↑	↑	↑	↑	↓	↓	↓	↓	↑	↑	↑	↑	↓	↑	-	↑
Gasoline 100 octane	-	↑	↑	↑	-	-	↓	↑	-	↑	-	-	↓	↓	-	↑	↑	↑	↓	↓	↑	↑	↑
Glycolic acid	↓	↑	↑	↑	-	↓	-	↓	-	↑	-	-	-	↓	-	-	↓	↓	↓	↑	↑	↑	-
Glycol	↑	↑	↑	↑	-	↑	↑	-	-	↑	↑	↑	↑	↑	↑	↑	↑	↑	↓	-	↑	↑	-
Helium	↑	↑	↑	↑	↑	↑	↑	↓	↑	↑	-	↑	↑	↑	↑	↑	↑	↑	↑	↑	↑	↑	-
Heptane	↑	↑	↑	↑	↑	↑	↑	↑	↑	↑	↑	↑	↑	↓	↑	↑	↑	↑	↑	-	↑	↑	↓
Hydraulic fluids	→	↑	↑	↑	↑	↑	↑	↑	-	↑	-	-	↓	↓	↑	↑	↓	↓	↓	↓	↓	↑	↑
Hydraulic oil	↑	↑	↑	↑	↑	↑	↑	↓	-	↑	↑	↑	↓	↓	↑	↑	↓	↓	↓	↓	↓	↑	↑
Hydrofluoric acid (50%)	↓	↓	↓	↓	↓	↓	↓	↓	↓	↓	↓	↓	↓	↓	↑	↑	↓	↓	↓	↓	↓	↑	↓
Hydrogen gas	↑	↑	↑	↑	↓	↑	↑	↓	↑	↑	↑	↑	↑	↑	↑	↑	↑	↑	↑	↑	-	↑	↑
Hydrogen peroxide (30%)	↓	↓	↓	↓	↓	↓	↓	↓	↑	↓	↓	↓	↓	↓	↓	↑	↑	↓	-	↑	↓	↑	↓
Hydrogen sulfide (dry hot)	↓	↓	↑	↑	↓	↓	↓	↓	↓	↓	↓	↓	↓	↓	↑	↑	↓	↓	↓	↑	↑	↑	↑
Isobutylene	↑	↑	↑	↑	↑	↑	↑	↑	-	↓	-	-	↓	↓	↑	↑	↓	↓	-	-	↑	-	-
Jet fuels (JP1 through 5)	↑	↑	↑	↑	↑	↑	↓	↓	-	↓	-	-	↓	↓	↑	↑	↑	↑	↓	↓	↑	↑	-
Jet fuels (JP 6)	↑	↑	↑	↑	-	↑	↑	↓	-	-	-	-	↑	↓	↓	↑	↑	↑	↓	↓	↑	↑	-
Kerosene (kerosine)	↑	↑	↑	↑	↑	↑	↑	↑	↑	↑	↑	↑	↓	↓	↑	↑	↑	↑	↓	↓	↑	↑	↑
Lactic acid	↓	↑	↑	↑	↓	↓	↓	↓	↓	↑	↑	↓	↓	↓	↑	↑	↓	-	↑	↑	↑	↑	↓
Liquid natural gas (LNG)	-	↑	↑	↑	↑	-	-	↑	-	-	-	-	-	-	-	-	-	-	-	-	-	↑	-
Liquid oxygen (LOX)	↓	↓	↓	↓	↓	↓	↓	↑	↓	-	↓	-	↓	↓	↓	↓	↓	↓	↓	-	-	↑	-

Please note that the chemical resistance may be influenced by many factors, such as temperature, concentration, etc. This data is for reference only.

Fluids	body materials											other materials in contact with fluid											
	Steel	Stainless Steel AISI 303/304	Stainless Steel AISI 316	Stainless Steel AISI 316L	Aluminum	Bronze	Cast Iron	Brass	PA	PEEK	PPS	Silver	Copper	CR	EPDM	FFKM	FKM	NBR	UR	PET	POM	PTFE	TPE
Liquid petroleum gas (LPG)	-	↑	↑	↑	↓	-	-	-	↓	-	↑	↑	↑	↓	↓	↑	↑	↑	↑	↓	↓	↑	↓
Lubricating oils, di-ester	↑	↑	↑	↑	↓	↑	↑	↑	↓	-	↑	↑	↑	↓	↓	↑	↑	↑	↑	↓	↓	↑	↓
Lubricating oils, petroleum base	↑	↑	↑	↑	↑	↑	↑	↑	↑	-	-	↑	↑	↓	↓	↑	↑	↑	↑	↓	↓	↑	↑
Lubricating oils, SAE 10, 20, 30, 40	↑	↑	↑	↑	↑	↑	↑	↑	↑	-	-	-	-	↓	↓	↑	↑	↑	↑	↓	↓	↑	↑
Magnesium acetate	↑	↑	↑	↑	↓	↓	↓	↓	↓	-	↑	-	-	↑	-	↓	↓	↓	-	↑	-	↑	-
Magnesium hydroxide	↑	↑	↑	↑	↓	↓	↓	↓	↓	↑	↑	↓	↓	↑	↑	↑	↑	↑	↓	↑	↑	↑	↑
Methane	↑	↑	↑	↑	↑	↑	↑	↑	↑	↑	↑	↑	↑	↓	↓	↑	↑	↑	↓	↓	↑	↑	↑
Methyl ether ketone (MEK)	↑	↑	↑	↑	↑	↑	↓	↓	↓	↓	↑	↑	↓	↓	↓	↑	↓	↓	↓	↓	↓	↑	↑
Mineral oil	↑	↑	↑	↑	↑	↑	↑	↑	↑	-	↑	↑	↑	↓	↓	↑	↑	↑	↑	↓	-	↑	↑
Morpholine	→	→	→	→	→	→	→	→	→	-	-	-	-	↓	↓	↑	↓	↓	-	-	-	↑	↑
Naphtha	↑	↑	↑	↑	↑	↑	↓	↓	↓	-	↑	↑	↑	↓	↓	↑	↑	↓	↓	↓	↑	↑	↑
Natural gas	→	↑	↑	↑	↑	↑	→	→	↑	↑	↑	↑	↑	↑	↓	↑	↑	↑	↑	↑	↑	↑	↑
Nitric acid (10%)	↓	↑	↑	↑	↓	↓	↓	↓	↓	↑	↓	-	↓	→	→	↑	↑	↓	↓	↑	↓	↑	→
Nitric acid, concentrated	↓	↑	↑	↑	↓	↓	↓	↓	↓	↓	↓	-	↓	↓	↓	→	↑	↓	↓	↓	↓	↑	↓
Nitro benzene	↑	→	↑	↑	↓	→	↓	-	↓	↑	↑	↑	↓	↓	↓	↑	→	↓	↓	→	→	↑	↓
Nitro methane	→	↑	↑	↑	↑	→	→	-	→	-	→	-	↑	↓	→	↑	↓	↓	↓	↓	↑	↑	↓
Nitrogen	↑	↑	↑	↑	↑	↑	↑	↑	↑	↑	↑	↑	↑	↑	↑	↑	↑	↑	↑	↑	↑	↑	→
Nitro propane	-	↑	↑	↑	↑	-	↑	-	-	-	-	-	-	↓	↓	↑	↓	↓	↓	-	-	↑	-
Octane	-	-	↑	↑	-	-	-	-	-	-	-	-	-	↓	↓	↑	↑	↑	↓	↓	↓	↑	-
Octane carboxylic acid	-	-	-	-	-	-	-	-	-	-	-	-	-	-	-	-	-	↑	↓	-	-	↑	-
Octanol	-	-	↑	↑	-	-	-	-	-	-	-	-	-	→	↑	-	↑	→	↓	-	-	↑	-
Oleic acid	↓	→	↑	↑	↑	→	→	↓	↑	-	-	↑	↓	→	↓	↑	→	→	→	↑	↑	↑	↑
Olive oil	↑	→	↑	↑	↑	↑	↑	→	→	-	↑	-	-	→	→	↑	↑	↑	↑	↑	↑	↑	-
Oxygen, cold	→	→	→	→	→	→	-	↑	-	-	-	-	→	↑	↑	↑	↑	→	↑	-	-	↑	-
Oxygen 121 - 204 °C (250 - 400 °F)	-	-	-	-	-	-	-	-	↓	-	↓	-	-	↓	↓	↑	↓	↓	↓	-	-	↑	-
Oxygen, gas	↑	↑	↑	↑	-	↑	↑	↑	→	-	↓	→	↑	→	↑	-	↑	↓	↑	-	-	↑	-
Ozone (dry)	↑	↑	↑	↑	→	↑	↑	↑	↓	↓	↓	→	↓	↓	↑	↑	↑	↑	↑	↓	↓	-	↓
Palm oil	↓	↑	↑	↑	↑	↓	↑	-	-	-	-	-	-	↓	-	-	↑	→	→	→	→	↑	-
Palmitic acid	↓	→	↑	↑	↓	↓	↓	↑	-	→	-	-	→	→	↑	↑	↑	↑	↑	-	-	↑	-
Paraffin	↑	↑	↑	↑	↑	↑	↑	↑	↑	↑	-	-	→	→	↓	↑	↑	↑	→	↑	↑	↑	-
Pentane	-	→	↑	↑	↑	-	→	↓	→	-	-	↑	→	↑	↓	↑	↑	↑	↓	-	↑	↑	-
Pentanol	-	-	-	-	-	-	-	-	-	-	-	-	-	↑	↑	-	→	→	↓	-	-	↑	-
Perchloroethylene ("Perk")	→	↑	↑	↑	↓	→	→	-	↓	↑	↓	↑	→	↓	↓	↑	↑	↓	↓	↓	↑	↑	↓
Petrol	→	↑	↑	↑	→	↑	→	↓	↑	↑	↑	-	-	→	↓	↑	↑	↑	→	↑	↑	↑	-
Petroleum benzine	↑	↑	↑	↑	↓	-	↑	→	→	-	↑	-	-	→	↓	-	↑	↑	→	-	-	↑	-
Petroleum ether	→	↑	↑	↑	→	-	→	↑	↑	↑	↑	-	-	→	↓	↑	↑	↑	→	↑	↑	↑	-
Petroleum naphtha	↑	↑	↑	↑	↑	↑	-	-	→	-	-	-	-	→	↓	-	↑	↑	→	-	→	↑	-
Petroleum oil above 121 °C (250 °F)	↑	↑	↑	↑	↓	↑	-	-	→	-	-	-	-	↓	↓	↑	→	↑	↓	-	→	↑	-
Petroleum oil below 121 °C (250 °F)	↑	↑	↑	↑	↓	↑	-	-	→	-	-	↑	↑	→	↓	↑	→	↑	→	-	→	↑	-
Phenol	→	→	→	→	→	→	↓	→	↓	→	↑	↑	→	↓	↓	↑	↑	↓	↓	↓	↑	↑	↓
Phenilic acid	-	-	↑	-	-	→	-	↓	-	-	-	-	-	↓	↓	-	→	↓	↓	-	-	↑	-
Phosphoric acid 10%	→	→	→	→	↓	→	↓	↓	↓	↑	↑	→	↓	→	↑	↑	↑	↑	↑	↑	↓	↑	-
Phosphoric acid, concentrated	↓	↓	↓	↓	↓	↓	↓	↓	↓	↓	↑	→	↓	↓	→	↑	↑	↓	↑	↑	↓	↑	↓
Pine oil	-	↑	↑	↑	↑	↑	→	→	↑	↑	→	-	-	↓	↓	↑	↑	→	-	-	↑	↑	↓
Poly propylene glycol	↑	↑	↑	↑	↑	↑	↑	↑	→	-	↑	-	-	↓	↓	↑	↑	↑	→	-	↑	↑	-
Potassium acetate	-	→	→	→	↓	-	↑	-	-	-	↑	-	→	→	↑	↑	↓	→	↓	↑	↑	↑	-
Potassium bicarbonate	↑	→	→	→	↓	→	↓	-	→	-	-	-	↓	↑	-	↑	↑	↑	-	-	↓	↑	-
Potassium carbonate	↑	→	↑	↑	↓	→	↑	→	→	↑	↑	-	-	↑	↑	↑	↑	↑	-	-	-	↑	-
Potassium chloride	↓	↓	↓	↓	→	↑	→	↓	→	↑	↑	↓	→	↑	↑	↑	↑	↑	↑	↑	↑	↑	↓
Potassium hydroxide (50%)	→	↑	↑	↑	↓	↓	↓	↓	↓	↑	→	→	↓	→	↑	↓	↓	→	↑	↑	↑	↑	↑

Please note that the chemical resistance may be influenced by many factors, such as temperature, concentration, etc. This data is for reference only.

Fluids	body materials													other materials in contact with fluid										
	Steel	Stainless Steel AISI 303/304	Stainless Steel AISI 316	Stainless Steel AISI 316L	Aluminum	Bronze	Cast Iron	Brass	PA	PEEK	PPS	Silver	Copper	CR	EPDM	FKM	FKM	NBR	UR	PET	POM	PTFE	TPE	
Potassium nitrate	→	↘	↑	↑	↑	↑	↘	↘	↘	↑	↑	↘	→	↑	↑	↑	↑	↑	↑	↑	↘	↑	-	
Potassium phosphate	→	→	→	→	↘	-	↘	↘	↘	↑	-	→	↑	↑	↑	↑	↑	↑	-	-	-	↑	-	
Potassium sulfate	↑	↑	↑	↑	↑	↘	↘	↘	↘	↑	↑	→	↑	↑	↑	↑	↑	↑	↑	-	-	↑	-	
Propane	↑	↑	↑	↑	↑	↑	↘	↘	↘	↑	↑	↑	↑	↘	↘	↑	↑	↑	↘	↘	-	↑	↘	
Propanol	↑	↑	↑	↑	-	-	↑	↑	↘	↑	↑	-	-	↑	↑	-	↘	↘	↘	-	-	↑	-	
Propylene	↑	↑	↑	↑	↑	-	↑	↑	-	-	-	↑	↑	↘	↘	↑	↑	↘	↘	↑	↑	↑	-	
Propylene chloride	-	→	↑	↑	↘	-	↑	-	-	-	-	-	-	↘	↘	↑	→	↘	↘	-	-	↑	-	
Pydraul 10E, 29ELT	-	↑	↑	↑	-	-	↑	-	-	-	-	↑	→	↘	→	↑	↑	↘	↘	-	-	↑	-	
Pyridine	↑	→	↑	↑	→	→	↘	↘	↑	↑	↑	-	↘	↘	→	↑	↘	↘	↘	↘	-	↑	↘	
Saccharose	→	↑	↑	↑	-	-	↑	↑	-	-	→	-	→	↑	↑	-	↑	↑	↘	-	-	↑	-	
SAE oils	-	-	-	-	-	-	-	-	-	-	-	-	→	→	↘	-	↑	↑	↑	-	-	↑	-	
Salt water	-	↘	↘	↘	↘	↑	↘	↘	↑	-	↑	-	→	↑	↑	↑	↑	↑	↘	↑	↑	↑	↑	
Soda	→	↑	↑	↑	↘	→	→	→	↑	-	↑	↑	→	→	↑	↑	→	↘	→	-	↑	↑	→	
Sodium carbonate	↑	→	↑	↑	↘	↑	→	→	→	-	↑	↑	→	↑	↑	↑	↑	↑	-	↑	↑	↑	→	
Sodium chloride	↘	↘	→	→	↘	↑	→	↘	→	↑	↘	→	→	↑	↑	↑	↑	↑	↑	↑	↑	↑	↑	
Sodium hydroxide (caustic soda)	↑	→	↑	↑	↘	↑	↘	↘	↑	↑	→	↑	↘	→	↑	↑	→	↘	→	↑	↑	↑	↘	
Sodium hypochlorite	↘	↘	↘	↘	↘	↘	↘	↘	↘	↑	↘	→	↘	↘	→	↑	↑	↘	↘	→	↘	↑	↘	
Sour natural gas	-	-	→	→	-	-	-	-	-	-	-	-	-	-	↘	↑	↘	↘	↘	-	-	↑	-	
Steam to 107 °C (225 °F)	↑	↑	↑	↑	↘	↑	↑	↑	↘	-	→	→	→	↘	↑	↑	↘	↘	↘	-	-	↑	-	
Steam 107 - 148 °C (225 - 300 °F)	↑	↑	↑	↑	↘	↑	↑	↑	↘	-	→	-	-	↘	↑	↑	↘	↘	↘	-	-	↑	-	
Steam over 148 °C (300 °F)	↑	↑	↑	↑	↘	↑	↑	↑	↘	-	→	-	-	↘	↑	↑	↘	↘	↘	-	-	↑	-	
Stoddard solvent	↑	↑	↑	↑	↑	↑	↑	-	↑	-	↘	-	↑	↘	↘	↑	↑	↑	↑	↑	↑	↑	↘	
Sulphur dioxide, liquid	↑	→	↑	↑	↘	→	↘	↘	↘	↘	↑	↘	↘	→	↑	↑	↑	↘	-	↑	↘	↑	↘	
Sulphuric acid, concentrated	↘	→	→	→	↘	↘	↘	↘	↘	↘	→	↘	↘	→	↑	↑	↑	↘	↘	↘	↘	↑	↘	
Tetrachloroethylene	↑	↑	↑	↑	↘	-	↑	→	↘	-	→	↑	↑	↘	↘	↑	↑	↘	↘	↘	↑	↑	-	
Tetrahydrofuran	↑	↑	↑	↑	→	↑	-	-	↑	↑	↘	-	-	↘	→	↑	↘	↘	↘	↘	↘	↑	→	
Toluene	→	↑	↑	↑	↑	↑	↑	↑	↑	↑	→	↑	↑	↘	↘	↑	↑	↘	↘	-	↘	↑	↘	
Tri chloro ethylene	→	→	→	→	→	→	→	↑	↘	↑	→	-	↘	↘	↘	↑	↑	↘	↘	↘	→	↑	↘	
Tri chloro acetic acid	↘	↘	↘	↘	↘	-	↘	↘	↘	-	↑	-	↘	↘	→	↑	↘	→	↘	→	↘	↑	↘	
Turpentine	↑	→	↑	↑	↑	↑	→	↘	→	-	↑	↑	→	↘	↘	↑	↑	↑	↘	→	↑	↑	→	
Vaseline	↑	↑	↑	↑	-	-	↑	↑	↑	-	↑	-	-	→	↘	-	↑	↑	↑	-	-	↑	-	
Vegetable oils	↑	↑	↑	↑	↑	↑	→	→	↑	-	-	-	-	↘	→	↑	↑	↑	-	↑	↑	↑	-	
Vinegar	↘	↑	↑	↑	↘	↘	↘	↘	↑	-	↑	↑	→	→	↑	↑	↑	↘	↘	↑	→	↑	↘	
Water	-	↑	↑	↑	-	-	-	-	-	-	-	-	-	→	↑	↑	→	↑	↘	-	-	↑	↑	
Water, acid mine	↘	→	↑	↑	↘	↘	↘	↑	-	↑	-	↘	↑	↑	-	↑	→	-	↑	↑	↑	↑	↑	
Water, deionized	↘	↑	↑	↑	↑	→	↘	↘	↘	-	↑	-	→	↑	↑	→	↑	→	-	-	→	↑	↑	
Water, distilled lab	↘	↑	↑	↑	↑	↑	→	→	→	↑	↑	↑	↘	↘	↑	-	↑	↑	↑	↑	→	↑	↑	
Water, drinking	-	↑	↑	↑	↑	-	-	↘	↑	-	-	-	→	↑	-	↑	↑	↑	↘	-	-	↑	↑	
Water, fresh	↑	↑	↑	↑	→	↑	→	↑	↑	-	↑	↑	→	→	↑	-	↑	↑	↑	↑	↑	↑	↑	
Water, heavy	-	-	-	-	-	-	-	-	↑	-	↑	-	-	→	↑	↑	↑	↑	↘	↑	↑	↑	↑	
Water, sea/river	↘	→	→	↑	→	→	↘	↘	→	↑	↑	↑	→	→	↑	-	↑	→	↑	↑	↑	↑	↑	
Water glass	↑	↑	↑	↑	-	-	↑	→	↑	-	↑	-	→	↑	↑	-	↑	↑	↘	↑	↑	↑	↑	
Waterproofing salt	-	↘	↘	↘	→	↑	↘	→	↑	-	↑	-	-	→	-	-	-	→	↘	↑	↑	↑	↑	
Xenon	↘	↑	↑	↑	↑	-	↘	↑	↑	↑	↑	-	-	↑	↑	↑	↑	↑	↑	↑	-	↑	-	
Xylene	↑	→	→	→	↑	↑	→	→	→	↑	→	↑	↑	↘	↘	↑	↑	↘	↘	→	↑	↑	→	
Zinc chloride	↘	↘	↘	↘	↘	↘	↘	↘	↑	↑	↑	→	↘	↑	↑	↑	↑	↑	↑	↑	↘	↑	↑	

Please note that the chemical resistance may be influenced by many factors, such as temperature, concentration, etc.
This data is for reference only.

CONVERSION TABLES

Length				
	meter	inch	foot	yard
1 m	1	39.37	3.2808	1.0936
1 in	0.0254	1	0.0833	0.0278
1 ft	0.3048	12	1	0.033
1 yd	0.9144	36	3	1

1 m = 10⁻³ km = 10 dm = 102 cm = 103 mm = 106 μm = 1012 nm

Area					
	cm ²	m ²	sq. inch	sq. foot	sq. yard
1 cm ²	1	1 x 10 ⁻⁴	0.155	1.0764 x 10 ⁻³	1.196 x 10 ⁻⁴
1 m ²	1 x 10 ⁴	1	1550	10.764	1.196
1 sq in	6.4516	0.64516 x 10 ⁻³	1	0.00694	0.772 x 10 ⁻³
1 sq ft	929.0	0.0929	144	1	0.1111
1 sq yd	8360	0.8360	1296	9	1

1 m² = 10⁻⁶ km² = 10⁻⁴ ha = 100 dm² = 10⁶ mm²

Volume						
	liter (dm ³)	m ³	cubic inch	cubic foot	gallons	
					US	Imperial
1 l	1	1 x 10 ⁻³	61.024	0.03531	0.2642	0.220
1 m ³	1000	1	61024	35.31	264.2	220
1 cu in	16.387 x 10 ⁻³	16.387 x 10 ⁻⁶	1	0.5787 x 10 ⁻³	4.329 x 10 ⁻³	3.606 x 10 ⁻³
1 cu ft	28.320	28.320 x 10 ⁻³	1728	1	7.481	6.229
1 US gal	3.785	3.785 x 10 ⁻³	231	0.1337	1	0.8327
1 Imp gal	4.546	4.546 x 10 ⁻³	277.3	0.1605	1.210	1

Imperial = British

Specific Volume			
	ltr/kg	m ³ /kg	cubic foot pound
1 ltr/kg	1	0.001	0.01602
1 m ³ /kg	1000	1	16.02
1 cu ft/lb	62.43	0.06243	1

Mass				
	kilogram	pound	tons	
			short (US)	long (Imp)
1 kg	1	2.205	1.102 x 10 ⁻³	0.9843 x 10 ⁻³
1 lb	0.4536	1	0.500 x 10 ⁻³	0.4464 x 10 ⁻³
1 short ton (US)	907.2	2000	1	0.8929
1 long ton (Imp)	1016	2240	1.12	1

1 kg = 10³ g = 102 dkg

Density					
	kg/ltr	kg/m ³	pound cubic foot	pound gallon	
				Imperial	US
1 kg/ltr	1	1000	62.43	10.022	8.345
1 kg/m ³	0.001	1	0.06243	0.010022	0.008345
1 lb/cu ft	0.01602	16.02	1	0.16054	0.1337
1 lb/gal (Imp)	0.0998	99.78	6.229	1	0.8327
1 lb/gal (US)	0.1198	119.8	7.481	1.201	1

Force			
	Newton	kilopound	poundal
1 N	1	0.1020	7.24
1 kp	9.807	1	70.90
1 pdl	0.1383	0.0141	1

1 N = 10⁵ dyn; 1 dyn = 1 g x 1 $\frac{cm}{s^2}$; 1 kg = 1 kg x g
1 Poundal = 1 Pound x g

	1 bar = 10 ⁵ N/m ²	1 at = 1 Kp/cm ²	poundal/sq ft	poundal/sq in = Psi	1 atm = 760 Torr = 760 mm Hg (0 °C)			H ₂ O column (WC) (4 °C)	
					Hg column (0m °C)		m H ₂ O	ft H ₂ O	
					Hg (0 °C)	mm Hg = Torr			in Hg
1 Pa = 1 N/m ²	1 x 10 ⁻⁵	1.02 x 10 ⁻⁵	0.0209	1.45 x 10 ⁻⁴	9.87 x 10 ⁻⁶	0.0075	2.95 x 10 ⁻⁴	1.02 x 10 ⁻⁴	3.35 x 10 ⁻⁴
1 bar	1	1.0197	2089	14.504	0.9869	750	29.5	10.20	33.5
1 at	0.980665	1	2048	14.22	0.96784	735.56	29.0	10.00	32.8
1 pdl/sq ft	0.4790 x 10 ⁻³	0.4882 x 10 ⁻³	1	6.944 x 10 ⁻³	0.4725 x 10 ⁻³	0.359	0.141	4.88 x 10 ⁻³	0.0160
1 pdl/sq in = psi	0.06895	0.07031	144	1	0.06806	51.7	2.04	0.703	2.31
1 atm	1.013	1.033	2120	14.70	1	760	29.09	10.33	33.9
1 mm Hg	1.330 x 10 ⁻³	1.360 x 10 ⁻³	2.78	0.0193	1.316 x 10 ⁻³	1	0.0394	0.0136	0.0446
1 in Hg	0.0339	0.0345	70.7	0.4910	0.0334	25.4	1	0.3450	1.133
1 m H ₂ O	0.0981	0.1000	205	1.4220	0.0968	73.6	2.90	1	3.28
1 ft H ₂ O	0.0299	0.0305	62.4	0.4340	0.0295	22.4	0.883	0.3050	1

1 N = Pa (Pascal) = 10 $\frac{dyn}{cm^2}$

1 kp = 10⁻⁴ $\frac{kp}{m^2}$ = 1 mm WC (at 4 °C)

Work, Energy, and Heat Content									
	1 kcal	1 kp m	Btu (British thermal unit)	ft poundal	1 kWh	Horsepower hour (hph)		ton-day of refrigeration	1 Joule = 1 Nm = 1 Ws
						metrical 75 kp m h/s	imperial 550 ft. lb h/s		
1 kcal	1	427.0	3.968	3088	1.163 x 10 ⁻³	1.581 x 10 ⁻³	1.560 x 10 ⁻³	13.779 x 10 ⁻⁶	4190
1 kpm	2.342 x 10 ⁻³	1	9.294 x 10 ⁻³	7.233	2.723 x 10 ⁻⁶	3.704 x 10 ⁻⁶	3.653 x 10 ⁻⁶	32.270 x 10 ⁻⁶	9.807
1 Btu	0.252	107.59	1	778.0	0.293 x 10 ⁻³	0.398 x 10 ⁻³	0.3931 x 10 ⁻³	3.472 x 10 ⁻⁶	1055
1 ft pdl	0.3238 x 10 ³	0.13826	1.285 x 10 ⁻³	1	0.377 x 10 ⁻⁶	0.512 x 10 ⁻⁶	0.505 x 10 ⁻⁶	4.462 x 10 ⁻⁹	1.356
1 kWh	860	367.1 x 10 ⁻³	3412.8	2.655 x 10 ⁶	1	1.360	1.341	11.850 x 10 ⁻³	2.6 x 10 ⁶
1 PSh	632.3	270 x 10 ⁻³	2509	1.953 x 10 ⁶	0.7353	1	0.9863	8.713 x 10 ⁻³	2.65 x 10 ⁶
1 hph	641.1	273.7 x 10 ⁻³	2545	1.980 x 10 ⁶	0.7457	1.014	1	8.834 x 10 ⁻³	2.68 x 10 ⁶
1 ton-day	72.57 x 10 ⁻³	30.99 x 10 ⁻³	288 x 10 ³	244.1 x 10 ⁶	84.39	144.78	113.2	1	304 x 10 ⁶
1 J	0.239 x 10 ⁻³	0.102	0.948 x 10 ⁻³	0.738	0.278 x 10 ⁻⁶	0.378 x 10 ⁻⁶	0.372 x 10 ⁻⁶	3.280 x 10 ⁻⁹	1

1 erg = 1 dyn cm = 10⁻⁷ Nm; 1 kJ = 10³ J

Capacity, Energy Flow, and Heat Flow

	1 kcal/h	1 kp m/s	British thermal unit per hour	1 kcal/s = British theor. unit of refrigeration	1 kW = 1 kJ/s	Horsepower hour (HP)		US Standard commercial ton of refrigeration	British commercial ton of refrigeration
						metrical 75 kp m/s	imperial 550 ft lb/s		
1 kcal/h	1	0.1186	3.968	0.278×10^{-3}	1.163×10^{-3}	1.581×10^{-3}	1.560×10^{-3}	0.331×10^{-3}	0.299×10^{-3}
1 kp m/s	8.4312	1	33.455	2.342×10^{-3}	9.804×10^{-3}	13.333×10^{-3}	13.150×10^{-3}	2.792×10^{-3}	2.520×10^{-3}
1 Btu/h	0.252	29.89×10^{-3}	1	0.07×10^{-3}	0.293×10^{-3}	0.398×10^{-3}	0.393×10^{-3}	0.083×10^{-3}	75.310×10^{-3}
1 kcal/s									
Br u r	3600	427.0	14.285×10^{-3}	1	4.186	5.693	5.615	1.190	1.078
1 kW	860.0	102.0	3414	0.2389	1	1.360	1.341	0.2846	0.2572
1 HP	632.3	75	2509.3	0.1756	0.736	1	0.9863	0.2094	0.1891
1 hp	641.2	76.04	2545	0.1781	0.7455	1.014	1	0.2123	0.21227
1 ton	3024	358.2	12.0×10^3	0.831	3.513	4.776	4.711	1	0.9037
1 Br ton	3340	396.9	13.26×10^3	0.9277	3.888	5.287	5.214	1.1045	1

Enthalpy Difference, Specific Heat

Δh	kJ/kg	kcal/kg	Btu/pound
1 kJ/kg	1	0.239	0.43
1 kcal/kg	4.19	1	1.80
1 Btu/lb	2.33	0.556	1

$$1 \frac{\text{cal}}{\text{g}} = \frac{\text{kcal}}{\text{kg}}$$

Entropy Difference, Specific Heat

Δs	kJ/kg K	kcal/kg °C	Btu/pound °F
1 kJ/kg K	1	0.239	0.239
1 kcal/kg °C	4.19	1	1
1 Btu/lb °F	4.19	1	1

Formulas for temperature calculation

$[^{\circ}\text{C}] = ([^{\circ}\text{F}] - 32) \times 5/9$	$[^{\circ}\text{F}] = [^{\circ}\text{C}] \times 9/5 + 32$	$[\text{K}] = [^{\circ}\text{C}] + 273.15$
---	---	--

Temperatures

Common temperatures in degrees Kelvin and corresponding Celsius and Fahrenheit equivalents

Kelvin (K)	Celsius (°C)	Fahrenheit (°F)
0	-273	-459
17	-256	-429
33	-240	-400
49	-224	-371
65	-208	-342
81	-192	-314
97	-176	-285
113	-160	-256
129	-144	-227
145	-128	-198
161	-112	-170
177	-96	-141
193	-80	-112
209	-64	-83
225	-48	-54
241	-32	-26
257	-16	-3

Kelvin (K)	Celsius (°C)	Fahrenheit (°F)
273	0	32
289	16	61
305	32	90
321	48	118
337	64	147
353	80	176
373	100	212
385	112	234
401	128	262
417	144	291
433	160	320
449	176	349
465	192	378
481	208	406
497	224	435
513	240	464
529	256	493

(Orifice) Sizes

Common valve orifice sizes and equivalents in mm

inches	mm
3/64 (0.0469)	1.19
1/16 (0.0625)	1.59
5/64 (0.0781)	1.98
3/32 (0.0937)	2.38
1/8 (0.1250)	3.18
5/32 (0.1562)	3.97
11/64 (0.1719)	4.37
3/16 (0.1875)	4.76
7/32 (0.2187)	5.55
1/4 (0.2500)	6.35
9/32 (0.2812)	7.14
5/16 (0.3125)	7.94





inches	mm
7/17 (0.4375)	11.11
1/2 (0.5000)	12.70
5/8 (0.6250)	15.88
11/16 (0.6875)	17.46
3/4 (0.7500)	19.05
1 (1.000)	25.40
1 1/8 (1.250)	28.58
1 1/4 (1.2500)	31.75
1 1/2 (1.5000)	38.10
1 3/4 (1.7500)	44.45
2 (2.0000)	50.80
3 (3.0000)	76.20

Maximize precision, reliability and functionality of your analytical and medical devices



ASCO[™]

Emerson delivers time-tested and innovative automation solutions designed to help you improve your device's overall accuracy and reliability. Contact us now for world-class technologies and services that can maximize your analytical or medical application. Getting started is easy. Visit Emerson.com/ASCO

-  Emerson.com
-  Facebook.com/EmersonAutomationSolutions
-  LinkedIn.com/company/Emerson-Automation-Solutions
-  Twitter.com/EMR-Automation

The Emerson logo is a trademark and service mark of Emerson Electric Co. Brand logotype are registered trademarks of one of the Emerson family of companies. All other marks are the property of their respective owners. © 2019 Emerson Electric Co. All rights reserved.

CT000027ENGB-01_03-20



CONSIDER IT SOLVED[™]



青岛秉诚自动化设备有限公司
地址：中国·青岛市重庆南路99号海尔云街甲3号楼7F

服务热线：4006-918-365
网址：<http://www.ivalve.cc>

传真：(86-532)585-10-365
Email：sales@bechinas.com