

Features

- 2-way normally closed operation
- For control of commercial and industrial oil burners
- Direct lift with resilient soft seating for tight shutoff
- Brass body construction
- Mountable in any position

Fluid

No. 2 Fuel Oil at 60 SSU
 No. 4 Fuel Oil at 300 SSU

Construction

Valve Parts in Contact with Fluids	
Body	Brass
Seals and Disc	FKM
Core Tube	305 Stainless Steel
Core and Plugnut	430F Stainless Steel
Springs	302 Stainless Steel
Shading Coil	Copper

Electrical

Standard Coil and Class of Inulation	Watt Rating and Power Consumption			Ambient Temp. °F	Spare Coil Family	
	AC				General Purpose	Explosionproof
	Watts	VA Holding	VA Inrush		AC	AC
F	6.1	16	30	5 to 131	238210	238214
H	6.1	16	30	5 to 140	238410	238414
F	9.1	25	40	5 to 131	238210	238214
H	9.1	25	40	5 to 140	238410	-
F	10.1	25	50	5 to 131	238610	238614
H	10.1	25	50	5 to 140	238810	-
F	17.1	40	70	5 to 131	238610	238614
H	17.1	40	70	5 to 140	238810	238814

Standard Voltages: 24, 120, 240 volts AC, 60 Hz (or 110, 220 volts AC, 50 Hz).
 Optional High Ambient Temp: 140°F Class H coil with prefix HT.

Solenoid Enclosures

Standard: Watertight, Types 1, 2, 3, 3S, 4, and 4X with 1/2" conduit hub.
Optional: RedHat II - Explosionproof and Watertight. To order, add Prefix "EF" to catalog numbers. (e.g. EF8262G011V)

Valve Response Time

Opening Time: Less than 1 second
Closing Time: Less than 1 second

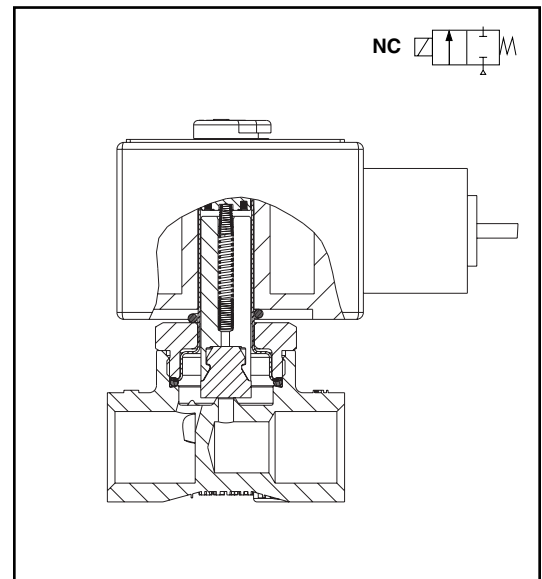

Approvals

UL listed to standard 429 "Electrically Operated Valves." Guide Y10Z, File MP618 Safety Shutoff Valves.

FM Approved to Class 7400 "Liquid and Gas Safety Shutoff Valves," & "Oil Safety Shutoff Valves."

CSA Certified to:

- 1) Standard C22.2 No. 139 "Electrically Operated Valves," File 010381.

COMBUSTION

Specifications (English units)

Pipe Size (in)	Orifice Size (in)	Cv Flow Factor	Operating Pressure Differential (psi)			Max. ① Fluid Temp. °F	Catalog Number	Const. Ref.	Agency			Wattage	Approx. Shipping Weight (lbs)
			Min.	Max.					UL	FM	CSA		
				#2 Fuel Oil at 60 SSU	#4 Fuel Oil at 300 SSU								
COMBUSTION (Fuel Oil) - NORMALLY CLOSED													
1/8	3/64	0.06	0	750	725	210	8262H001V	1	○	○	○	6.1	2.3
1/8	3/32	0.21	0	350	325	210	8262H011V	1	○	○	○	9.1	2.3
1/8	1/8	0.35	0	180	120	210	8262H002V	1	○	○	○	6.1	2.3
1/4	3/32	0.21	0	350	270	210	8262H021V	2	○	○	○	9.1	2.4
1/4	1/8	0.35	0	230	150	210	8262H023V	2	○	○	○	9.1	2.4
1/4	7/32	0.73	0	100	100	210	8262H208V	3	○	○	○	10.1	2.4
3/8	1/8	0.35	0	230	140	210	8263H003V	4	○	○	○	9.1	2.5
3/8	7/32	0.73	0	100	100	210	8263H206V	5	○	○	○	17.1	2.5

○ = Safety Shutoff Valve. ① Max. fluid temp. of 250°F with optional H Class coil (Prefix HT/HB)

Specifications (Metric units)

Pipe Size (in)	Orifice Size (mm)	Kv Flow (m³/hr)	Operating Pressure Differential (bar)			Max. ① Fluid Temp. °C	Catalog Number	Const. Ref.	Agency			Wattage	Approx. Shipping Weight (kgs)
			Min.	Max.					UL	FM	CSA		
				#2 Fuel Oil at 60 SSU	#4 Fuel Oil at 300 SSU								
COMBUSTION (Fuel Oil) - NORMALLY CLOSED													
1/8	1	0.5	0	51.7	50.0	99	8262H001V	1	○	○	○	6.1	1.0
1/8	2	0.18	0	24.1	22.4	99	8262H011V	1	○	○	○	9.1	1.0
1/8	3	0.3	0	12.4	8.3	99	8262H002V	1	○	○	○	6.1	1.0
1/4	2	0.5	0	24.1	18.6	99	8262H021V	2	○	○	○	9.1	1.1
1/4	3	0.3	0	15.9	10.3	99	8262H023V	2	○	○	○	9.1	1.1
1/4	6	0.63	0	6.9	6.9	99	8262H208V	3	○	○	○	10.1	1.1
3/8	3	0.3	0	15.9	9.7	99	8263H003V	4	○	○	○	9.1	1.1
3/8	6	0.63	0	6.9	6.9	99	8263H206V	5	○	○	○	17.1	1.1

○ = Safety Shutoff Valve. ① Max. fluid temp. of 121°C with optional H Class coil (Prefix HT/HB)

Capabilities Chart

NEMA Type 3-9	Solenoid Options		Base Catalog Number	Resilient Materials	Standard Rebuild Kit
	High Temp.	Wiring Box Screw Terminal	Brass	FKM	AC
EF	HT	JKF	8262H001V	●	323587-V
EF	HB	JKP	8262H011V	●	323581-V
EF	HT	JKF	8262H002V	●	323581-V
EF	HB	JKP	8262H021V	●	323581-V
EF	HB	JKP	8262H023V	●	323581-V
EF	HT	JKF	8262H208V	●	323593-V
EF	HB	JKP	8263H003V	●	323581-V
EF	HB	JKP	8263H206V	●	323593-V

● = Standard. Other options may be available. All option combinations may not be available.

COMBUSTION

Dimensions inches (mm)

Const. Ref.		H	K	L	P	W
1	in	2.85	1.60	1.19	2.50	1.69
	mm	72	41	30	63	43
2	in	2.96	1.72	1.56	2.60	1.69
	mm	75	44	40	66	43
3	in	3.12	1.79	1.56	2.76	1.95
	mm	79	45	40	70	50
4	in	3.01	1.68	1.88	2.57	1.69
	mm	76	43	48	65	43
5	in	3.20	1.79	1.88	2.77	1.95
	mm	81	45	48	70	50

Const. Ref. 1-5

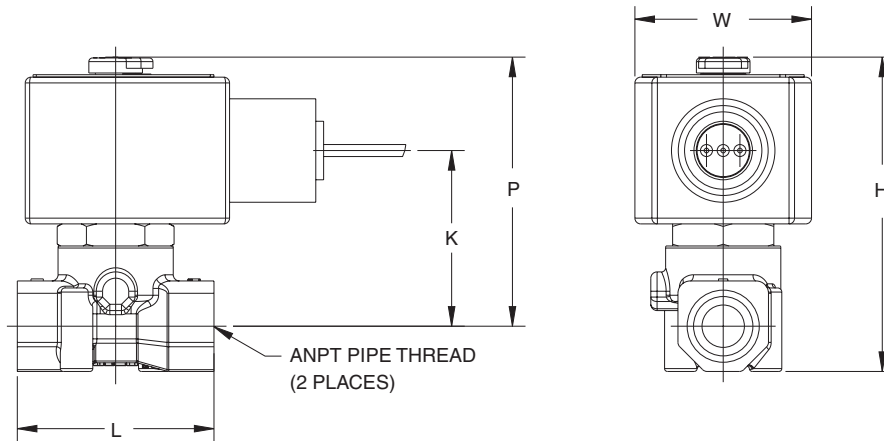

Mounting Dimensions

Const. Ref. 1 (1/8" Pipe)

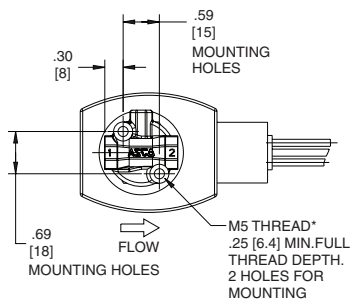

Const. Ref. 2, 3 (1/4" Pipe)

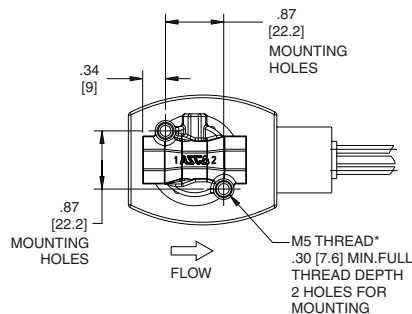

Const. Ref. 4, 5 (3/8" Pipe)

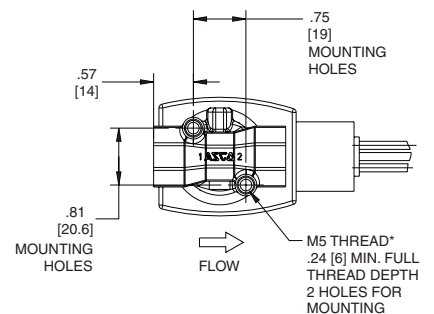

*ACCEPTS STANDARD #10-32 MACHINE SCREW

