

ASCO™ Tamper-Proof High-Shock Manual Reset Valves

Stainless Steel Bodies | 1/4" and 1/2" NPT

SERIES
EV8308
Manual Reset

Features

- Designed to keep the valve in the shut-off position when the solenoid is de-energized, even if the handle is lifted. The valve will not be in the open position until the solenoid is energized and auxiliary air is present.
- Once the solenoid is de-energized, it requires power to be restored to the solenoid then the valve to be manually reset. Ideal for controlling critical processes
- Designed to meet vibration and/or shock per ISA specification S71.03C2
- Handles aggressive atmosphere per salt resistance testing (ASTM B117)
- Most hardware is stainless steel, and all aluminum components are hard anodized and Nituff® coated
- SIL 3 capable per IEC 61508, certified by Exida

Nituff is a registered trademark of Nimet Industries, Inc.

Construction

Valve Parts in Contact with Fluids		
Main Valve		
Body	316 Stainless Steel	
Springs	302 Stainless Steel	
Seals	NBR / FKM	
Air Operator Diaphragm	FMQ	
Pilot Valve	AC 10.1 W	DC 1.4 W
Body	303 Stainless Steel	303 Stainless Steel
Shading Coil	Silver	NA
Seals	NBR	NBR / PTFE
Core Tube	305 Stainless Steel	305 Stainless Steel
Core and Plugnut	430F Stainless Steel	430F Stainless Steel
Core Guide	CA	CA
Core Springs	302 Stainless Steel	302 Stainless Steel

Electrical

Standard Coil and Class of Insulation	Watt Rating and Power Consumption				Spare Coil Part Number			
	DC Watts	AC			General Purpose		Explosionproof	
		Watts	VA Holding	VA Inrush	AC	DC	AC	DC
F	11.6	10.1	25	76	238610	238710	238614	238714
F	1.4	-	-	-	-	-	274714-902-D*	

Standard Voltages: 24, 120, 240, 480 volts AC, 60 Hz. 12, 24 volts DC.
Must be specified when ordering.
* 24 VDC. For other voltages contact factory.



Solenoid Enclosures

Standard: Explosionproof and Watertight, Types 3, 3S, 4, 4X, 6, 6D, 7, and 9.

Approvals

CSA certified and UL listed General Purpose Valve (solenoid only)
ATEX/IECEx certified with prefix "EV" as listed.

SIL 3 capable per IEC 61508.

Third party certification provided by EXIDA.

Refer to Optional Features Electrical Section for details.

Options

Position indicator switch - GO™ Switch (suffix SP)

Contact factory for ordering information.

Operation Alternatives

No Voltage Release – With the pilot valve solenoid energized, the handle is raised manually and latches the operator in the "up" (latched) position. Upon loss of voltage, the latch is tripped returning the operator to the "down" (unlatched) position. If auxiliary air supply to the pilot valve is lost, the main valve will shift position.

Moving the handle while the valve is in the tripped state will not cause the actuator/process valve to shift.

Specifications English units (Metric)

Pipe Size (in)	Orifice Size (in)	Flow Factor Cv (Kv)	Operating Pressure Differential psi (bar)			Fluid Temp. °F (°C)		Max. Ambient Temp. °F (°C)	Catalog Number	Const. Ref.	Body Material	Pilot Construction	Watt Rating/ Class of Coil Insulation per Solenoid	
			Pilot Min.	Pilot Max.	Main Max.	Min.	Max.						AC	DC
3/2 Tamperproof High-Shock Manual Reset Valves - SIL 3 capable, certified by Exida														
1/4	5/16	1.5 (1.3)	25 (1.7)	125 (9)	150 (10)	-4 (-20)	180 (82)	125 (52)	EV8308G060 ①	1	Stainless Steel	No Voltage Release (NVR)	10.1/F	-
1/4	5/16	1.5 (1.3)	25 (1.7)	125 (9)	150 (10)	-4 (-20)	140 (60)	140 (60)	EV8308G360 ①	1	Stainless Steel	No Voltage Release (NVR)	-	1.4/F
1/2	5/8	4 (3.4)	25 (1.7)	125 (9)	150 (10)	-4 (-20)	180 (82)	125 (52)	EV8308G061 ①	2	Stainless Steel	No Voltage Release (NVR)	10.1/F	-
1/2	5/8	4 (3.4)	25 (1.7)	125 (9)	150 (10)	-4 (-20)	140 (60)	140 (60)	EV8308G361 ①	2	Stainless Steel	No Voltage Release (NVR)	-	1.4/F

① ATEX/IECEx certified with prefix "EV".

Dimensions Inches (mm)

Const. Ref. 1

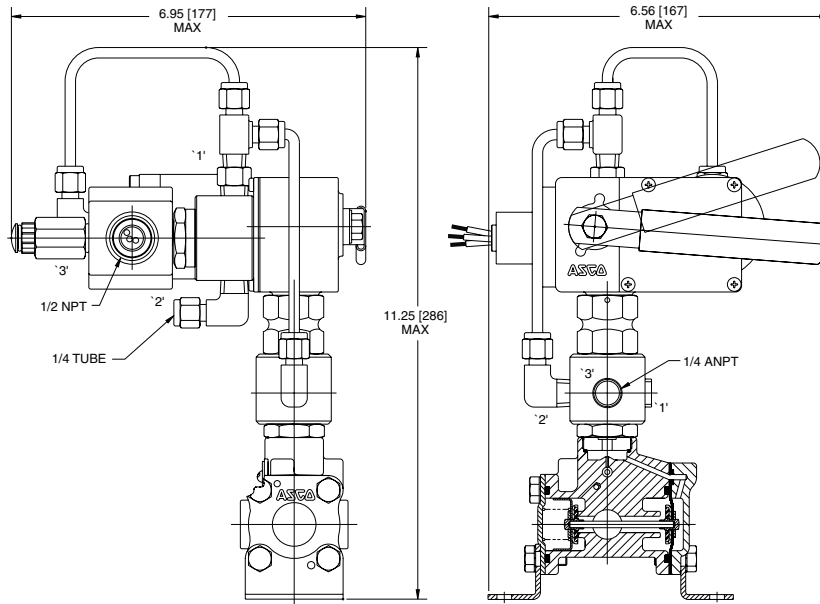

Const. Ref. 2

