

ASCO™ General Service Solenoid Valves

Direct Acting | Brass or Stainless Steel Bodies | 1/8" to 1/4" NPT

3/2
SERIES
314

Features

- No minimum operating pressure required
- The original 3-way valve design
- Simplest valve for basic 3-way piloting operation, only a spring and two moving parts
- Moderate flow pilots, smaller control valves and actuators
- Can also be used for low-volume fluid diversion
- High-speed general service

Construction

Valve Parts in Contact with Fluids		
Body	Brass	Cast 304 Stainless Steel
Seals and Disc	Nitrile (Upper Disk - FKM)	
Core Tube	305 Stainless Steel	
Core and Plugnut	430F Stainless Steel	
Core Springs	302 Stainless Steel	
Shading Coil	Copper	Silver
Core Guide	POM	

Electrical

Standard Coil and Class of Insulation	Watt Rating and Power Consumption				Spare Coil Part Number			
	DC Watts	AC			General Purpose		Explosionproof	
		Watts	VA Holding	VA Inrush	AC	DC	AC	DC
F	11.6	10.1	25	50	238610	238710	238614	238714

Standard Voltages: 24, 120, 240, 480 volts AC, 60 Hz (or 110, 220 volts AC, 50 Hz).
6, 12, 24, 120, 240 volts DC. Must be specified when ordering.
Other voltages are available when required.

Solenoid Enclosures

Standard: Watertight, Types 1, 2, 3, 3S, 4, and 4X.

Optional: Explosionproof and Watertight, Types 3, 3S, 4, 4X, 6, 6P, 7, and 9.
(To order, add prefix "EF" to the catalog number.)

See Optional Features Section for other available options.

Options

Mounting bracket (suffix MB)

Quarter-turn manual operator with screw slot (suffix MS)

FKM (suffix V)

Oxygen (suffix N)

Silicon Free (suffix SF)

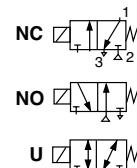
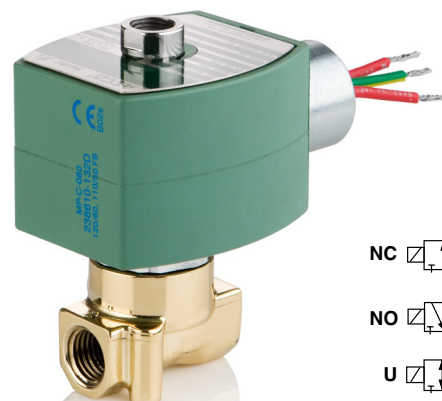

Nominal Ambient Temp. Ranges

The nominal limitation of 32°F (0°C) is advisable for any valve that might contain moisture (water vapor).

AC: -13°F to 131°F (-25°C to 55°C)*

DC: -13°F to 131°F (-25°C to 55°C)

*Max. ambient for explosionproof (EF/EV) is 125°F (52°C)

Optional: For AC, the max. ambient temperature is 140°F (60°C) with Class H coil (with or without prefix EF/EV)

Refer to Engineering Section for details.

Approvals

- CSA certified, UL listed General Purpose Valves.
- Meets applicable CE directives.
- SIL 3 capable per IEC 61508 on normally closed constructions.
Third party certification provided by EXIDA.
Refer to Engineering Section for details.
- ATEX/IECEX certified with prefix "EV" as listed.
Refer to Optional Features Electrical Section for details.

Specifications (English units)

Pipe Size (in)	Orifice Size in (mm)	Cv (Kv) Flow Factor 2-1	Cv (Kv) Flow Factor 1-3	Operating Pressure Differential (psi)						Max. Fluid Temp. °F		Brass Body		Stainless Steel Body		Watt Rating/Class of Coil Insulation	
				Max. AC			Max. DC			AC	DC	Catalog Number	Const. Ref.	Catalog Number	Const. Ref.	AC	DC
				Air-Inert Gas	Water ②	Light Oil @ 45 SSU	Air-Inert Gas	Water ②	Light Oil @ 45 SSU								
Universal Operation (Pressure at any port)																	
1/8	3/64 (1.2)	0.05 (0.04)	0.06 (0.05)	200 (14)	200 (14)	200 (14)	200 (14)	200 (14)	200 (14)	200 (93)	200 (93)	8314H041	1	8314H042	1	10.1/F	11.6/F
1/8	3/32 (2.4)	0.15 (0.13)	0.20 (0.17)	105 (7)	85 (6)	60 (4)	105 (7)	85 (6)	60 (4)	200 (93)	200 (93)	8314H043	1	8314H044	1	10.1/F	11.6/F
1/8	1/8 (3.2)	0.25 (0.22)	0.20 (0.17)	70 (5)	70 (5)	40 (3)	55 (4)	45 (3)	45 (3)	200 (93)	200 (93)	8314H045	1	8314H040	1	10.1/F	11.6/F
1/4	3/64 (1.2)	0.05 (0.04)	0.06 (0.05)	200 (14)	200 (14)	200 (14)	200 (14)	200 (14)	200 (14)	200 (93)	200 (93)	8314H006	2	8314H123	2	10.1/F	11.6/F
1/4	3/32 (2.4)	0.15 (0.13)	0.20 (0.17)	105 (7)	85 (6)	60 (4)	105 (7)	85 (6)	60 (4)	200 (93)	200 (93)	8314H007	2	8314H120 ③	2	10.1/F	11.6/F
1/4	1/8 (3.2)	0.25 (0.22)	0.20 (0.17)	70 (5)	70 (5)	40 (3)	55 (4)	45 (3)	45 (3)	200 (93)	200 (93)	8314H008	2	8314H124	2	10.1/F	11.6/F
1/4	5/32 (4.0)	0.50 (0.43)	0.20 (0.17)	35 (2.5)	35 (2.5)	35 (2.5)	25 (2)	25 (2)	25 (2)	200 (93)	200 (93)	8314H127	2	8314H227	2	10.1/F	11.6/F
1/4	7/32 (5.6)	0.70 (0.60)	0.20 (0.17)	18 (1.5)	18 (1.5)	18 (1.5)	12 (1)	12 (1)	12 (1)	200 (93)	200 (93)	8314H128	2	8314H228	2	10.1/F	11.6/F
1/4	9/32 (7.1)	0.85 (0.73)	0.20 (0.17)	10 (0.7)	10 (0.7)	10 (0.7)	8 (0.6)	8 (0.6)	8 (0.6)	200 (93)	200 (93)	8314H129	2	8314H229	2	10.1/F	11.6/F
Normally Closed (Closed when de-energized) – PFD_{AVG} = 4.77 x 10⁻⁴																	
1/8	3/64 (1.2)	0.05 (0.04)	0.06 (0.05)	300 (21)	300 (21)	300 (21)	250 (17)	250 (17)	250 (17)	200 (93)	200 (93)	8314H031	1	8314H037	1	10.1/F	11.6/F
1/8	3/32 (2.4)	0.15 (0.13)	0.20 (0.17)	205 (14)	205 (14)	190 (13)	150 (10)	120 (8)	90 (6)	200 (93)	200 (93)	8314H032	1	8314H038	1	10.1/F	11.6/F
1/8	1/8 (3.2)	0.25 (0.22)	0.20 (0.17)	145 (10)	145 (10)	100 (7)	90 (6)	90 (6)	70 (5)	200 (93)	200 (93)	8314H033	1	8314H039	1	10.1/F	11.6/F
1/4	3/64 (1.2)	0.05 (0.04)	0.06 (0.05)	300 (21)	300 (21)	300 (21)	250 (17)	250 (17)	250 (17)	200 (93)	200 (93)	8314H034	2	8314H068	2	10.1/F	11.6/F
1/4	3/32 (2.4)	0.15 (0.13)	0.20 (0.17)	205 (14)	205 (14)	190 (13)	150 (10)	120 (8)	90 (6)	200 (93)	200 (93)	8314H035	2	8314H121 ③	2	10.1/F	11.6/F
1/4	1/8 (3.2)	0.25 (0.22)	0.20 (0.17)	145 (10)	145 (10)	100 (7)	90 (6)	90 (6)	70 (5)	200 (93)	200 (93)	8314H036	2	8314H126	2	10.1/F	11.6/F
1/4	5/32 (4.0)	0.50 (0.43)	0.20 (0.17)	75 (5.2)	75 (5.2)	75 (5.2)	50 (3.5)	50 (3.5)	50 (3.5)	200 (93)	200 (93)	8314H130	2	8314H230	2	10.1/F	11.6/F
1/4	7/32 (5.6)	0.70 (0.60)	0.20 (0.17)	40 (3)	40 (3)	40 (3)	25 (2)	25 (2)	25 (2)	200 (93)	200 (93)	8314H131	2	8314H231	2	10.1/F	11.6/F
1/4	9/32 (7.1)	0.85 (0.73)	0.20 (0.17)	25 (2)	25 (2)	25 (2)	15 (1)	15 (1)	15 (1)	200 (93)	200 (93)	8314H132	2	8314H232	2	10.1/F	11.6/F
Normally Open (Open when de-energized)																	
1/8	3/64 (1.2)	0.05 (0.04)	0.06 (0.05)	300 (21)	300 (21)	300 (21)	250 (17)	250 (17)	250 (17)	200 (93)	200 (93)	8314H049	1	8314H055	1	10.1/F	11.6/F
1/8	3/32 (2.4)	0.15 (0.13)	0.20 (0.17)	175 (12)	175 (12)	175 (12)	160 (11)	160 (11)	160 (11)	200 (93)	200 (93)	8314H050	1	8314H056	1	10.1/F	11.6/F
1/8	1/8 (3.2)	0.25 (0.22)	0.20 (0.17)	160 (11)	160 (11)	160 (11)	150 (10)	150 (10)	120 (8)	200 (93)	200 (93)	8314H051	1	8314H057	1	10.1/F	11.6/F
1/4	3/64 (1.2)	0.05 (0.04)	0.06 (0.05)	300 (21)	300 (21)	300 (21)	250 (17)	250 (17)	250 (17)	200 (93)	200 (93)	8314H052	2	8314H069	2	10.1/F	11.6/F
1/4	3/32 (2.4)	0.15 (0.13)	0.20 (0.17)	175 (12)	175 (12)	175 (12)	160 (11)	160 (11)	160 (11)	200 (93)	200 (93)	8314H053	2	8314H122	2	10.1/F	11.6/F
1/4	1/8 (3.2)	0.25 (0.22)	0.20 (0.17)	160 (11)	160 (11)	160 (11)	150 (10)	150 (10)	120 (8)	200 (93)	200 (93)	8314H054	2	8314H070	2	10.1/F	11.6/F
1/4	5/32 (4.0)	0.50 (0.43)	0.20 (0.17)	150 (10)	150 (10)	150 (10)	65 (4.5)	60 (4.2)	60 (4.2)	200 (93)	200 (93)	8314H133	2	8314H233	2	10.1/F	11.6/F
1/4	7/32 (5.6)	0.70 (0.60)	0.20 (0.17)	100 (7)	100 (7)	100 (7)	35 (2.5)	35 (2.5)	35 (2.5)	200 (93)	200 (93)	8314H134	2	8314H234	2	10.1/F	11.6/F
1/4	9/32 (7.1)	0.85 (0.73)	0.20 (0.17)	65 (4.5)	65 (4.5)	65 (4.5)	25 (2)	25 (2)	25 (2)	200 (93)	200 (93)	8314H135	2	8314H235	2	10.1/F	11.6/F

① Maximum fluid temperature for light oil @ 45 SSU is 180°F. ② Water rating, CSA certified up to 232 psi. ③ ATEX/IECEx certified with prefix "EV".

ASCO™ General Service Solenoid Valves

Direct Acting | Brass or Stainless Steel Bodies | 1/8" to 1/4" NPT

3/2
SERIES
314

Dimensions: inches (mm)

Const. Ref. 1

Const. Ref. 2

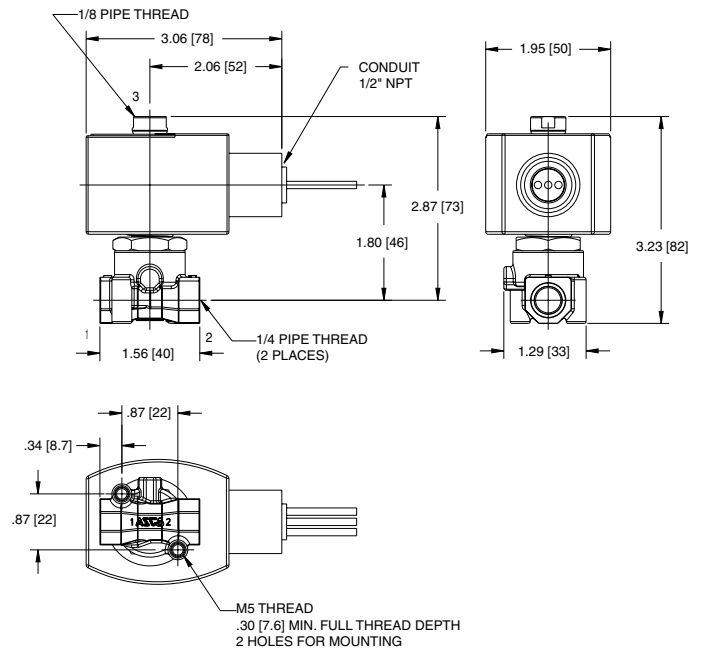
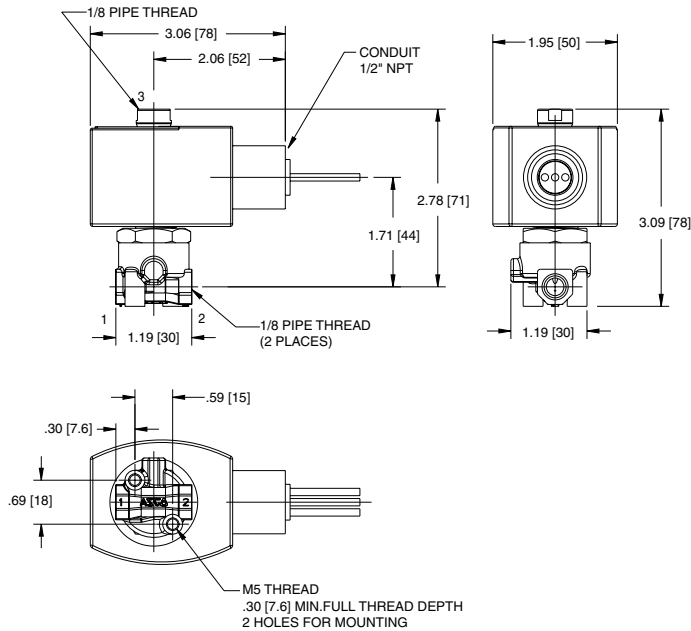

Flow Diagrams

Universal Construction
(Pressure at any Port)

Normally Closed Construction
(Pressure at 2)

Normally Open Construction
(Pressure at 3)

