

ASCO™ SOLENOID VALVE

2/2 NORMALLY OPEN – PILOT OPERATED - G 3/8 ÷ G 1

SERIES
L282

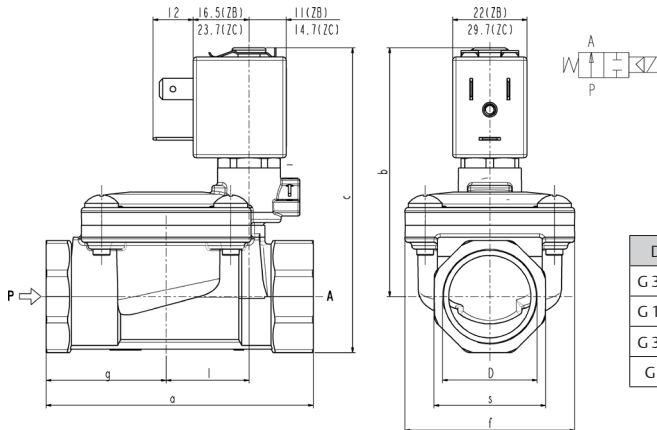

D	a	b	c	f	g	l	s
G 3/8	60	67	78	40	25,5	20	22
G 1/2	66	69	83	40	29	20	27
G 3/4	79	73,5	90	50	35,5	24,5	33
G 1	105	86	107	71	46	28	42



General Features

Diaphragm valve, pilot operated, having full orifice.
Suitable to shut off liquid and gaseous fluids (verify the compatibility of fluid with material in contact).

Technical Features	
Maximum allowable pressure (PS)	20bar
Opening time	from ~300ms to ~1500ms
Closing time	from ~1000ms to ~2000ms
Fluid temperature	-10°C +90°C (NBR) 0°C +130°C (FPM) -10°C +140°C (EPDM)* WRAS
Max viscosity	5°E (~37 cStokes or mm²/s)

* Maximum operating temperature 85°C in compliance with WRAS approval

Materials in Contact with Fluid	
Body	Brass
Sealing	NBR or FPM
Internal components	Brass and stainless steel
Seat	Brass
Core tube	Stainless steel
Shading coil	Copper

Coil	ZB10K ZC10A	ZB12K ZC12A	ZB14K ZC14A
Approval	/	▲UL and CSA	▲UL and CSA
Encapsulation material	PA fiberglass reinforced	PET fiberglass reinforced	PET fiberglass reinforced
Insulation class	F (155°C)	F (155°C)	H (180°C)
Ambient temperature	-10°C +60°C	-10°C +60°C	-10°C +75°C
Continuous duty	ED 100%		
Electric connection	DIN 46340- 3 poles plug connector (EN 175301-803 for ZC)		
Protection degree	IP 65 (EN 60529) with plug connector	IP 67 (EN 60529) with plug connector	IP 67 (EN 60529) with plug connector
Voltages	DC	ZC: 12-24V (+10% -5%)	
	AC	ZB: 24V/50-60Hz - 120V/60Hz - 230V/50-60Hz - 220-230/50Hz 208-240/60Hz (on request) - (+10% -15%) (Other voltages and frequencies on request)	

▲: approval valid for ZB12K – ZB14K only

Port size ISO 228	Orifice size (mm)	Differential pressure (bar)				Kv (m³/h)	Series and type		Power absorption				Sealings	Notes	Weight (kg)						
		Δp max					Valve	Coil	AC (VA)			DC									
		Gases		Liquids					Inrush	Holding						W					
3/8	13,5	0,35	12	-	12	-	ZB10K ZB12K	11,7	10	7,6	-	NBR FPM	-	0,32							
1/2															10	10	5	L282B01 L282V01	NBR FPM	0,38	
3/4	10		10	12	L282B01 L282V01	NBR FPM															1,08
1															10	10	2,5	L282B01 L282V01	NBR FPM	0,32	
3/8	13,5		-	12	12	3,8															ZC10A ZC12A
1/2															10	10	5	L282B01 L282V01	NBR FPM	0,52	
3/4	10		10	12	L282B01 L282V01	NBR FPM	1,08														
1								10	10	12	L282B01 L282V01	NBR FPM	1,08								

Notes

- Sealings: NBR=Nitrile-butylene elastomer FPM=Fluoro-carbon elastomer
- Operation with gaseous media, at high pressure without any outlet restriction, can reduce the diaphragm life.
- On request coil in class H (ZB14K – ZC14A - see § "COIL")
- WRAS approved solenoid valve (certificate n. 2007001).

ASCO™

www.Emerson.com/asco

EMERSON

BCAE
Automation Solutions

青岛秉诚自动化设备有限公司
地址：中国·青岛市重庆南路99号海尔云街甲3号楼7F

服务热线：4006-918-365
网址：http://www.ivalve.cc

传真：(86-532)585-10-365
Email：sales@bechinas.com

Spare Parts

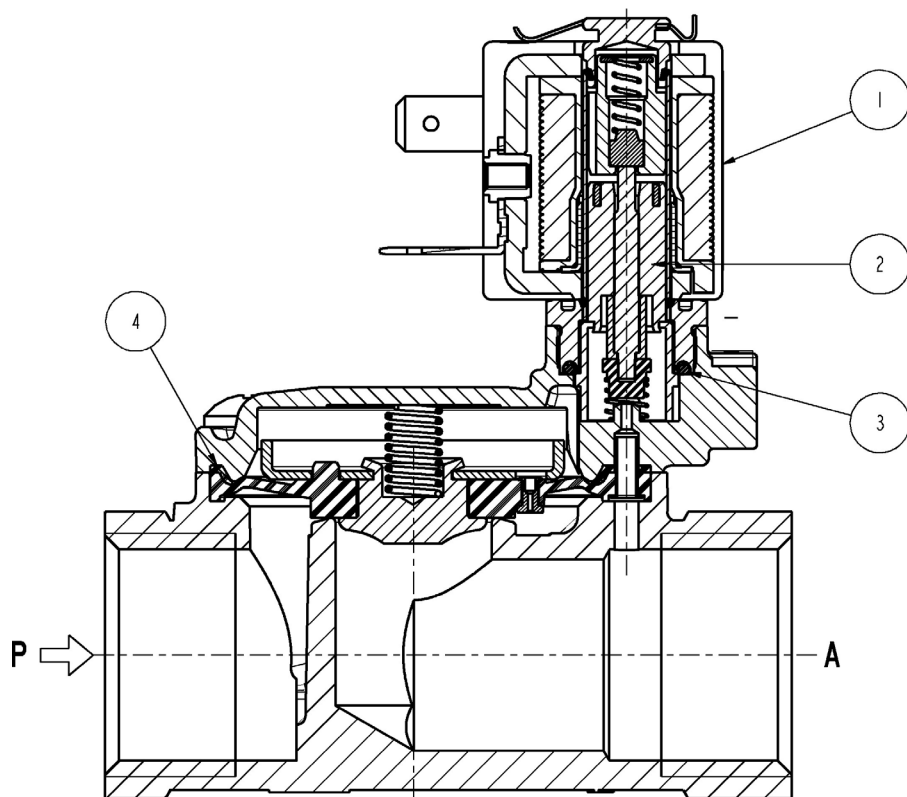

Kit description	Model	Port Size	Kit P.N.	Consisting of:
Actuator kit			G3139801	Actuator kit pos.2 O-Ring guide assembly pos. 3
Diaphragm assembly	L282B	G3/8-1/2	2844302R	Diaphragm assembly pos.4
		G3/4	2299701R	
		G1	2380101R	
	L282V	G3/8-1/2	2844303R	
		G3/4	2299702R	
G1	2380102R			
Coil			ZB ZC	Coil pos.1

Installation

- Solenoid valve can be mounted in any position; vertical with coil upwards preferred.

THE VALIDITY OF REPORTED DATA IS REFERRED TO THE DATE OF ISSUE. POSSIBLE UPDATES ARE AVAILABLE ON REQUEST