

# ASCO™ Solenoid Valves

For Cryogenic Service

Direct Operated, 1/8, 1/4 and 3/8 Tapped

2/2 NC  
Series

**262-263**

## Features

- The solenoid valves will withstand the severe service encountered in controlling cryogenic fluids, such as liquid oxygen (-183°C), liquid argon (-186°C) and liquid nitrogen (-196°C)
- All valves are degreased, cleaned, tested and packed to keep them free from moisture. In addition liquid oxygen (LOX) valves are “black light” tested to check for any hydrocarbons
- Valves do not require a minimum operating pressure
- Compliance with UL and CSA standards
- The solenoid valves satisfy all relevant EU directives

## General

**Differential pressure**

See «SPECIFICATIONS» [1 bar = 100 kPa]

**Maximum viscosity**

65 cSt (mm<sup>2</sup>/s)

**Response time**

5 - 25 ms

fluids (*)	temperature range (TS)	seal materials (*)
cryogenic fluids	-196°C to +60°C	PTFE

## Materials in contact with fluid

(\*) Ensure that the compatibility of the fluids in contact with the materials is verified

<b>Body</b>	Brass
<b>Shading coil</b>	Copper
<b>Core tube</b>	Stainless steel, AISI 305
<b>Core and plugnut</b>	Stainless steel, AISI 430F
<b>Springs</b>	Stainless steel, AISI 302
<b>Seal</b>	Lead-clad copper
<b>Disc</b>	PTFE

## Electrical characteristics

**Coil insulation class**

F (AC) or H (DC)

**Connector**

Spade plug (cable Ø 6-10 mm)

**Connector specification**

ISO 4400 / EN 175301-803, form A

**Electrical safety**

IEC 335

**Electrical enclosure protection**

Moulded IP65 (EN 60529)

**Standard voltages**

DC (=) : 24V - 48V

(Other voltages and 60 Hz on request)

AC (~) : 24V - 48V - 115V - 230V/50 Hz

operator ambient temperature range (TS) (°C)	power ratings			replacement coil <sup>(1)</sup>	
	inrush ~ (VA)	holding ~ (VA)	hot/cold = (W)	~ (W)	= (W)
-40 to +55	50	25	10,1	8,5/11,6	238613-059 238913-006
	70	40	17,1	15,1/22,6	238613-159 238913-106

<sup>(1)</sup> All 238 basic numbers are UL & CSA approved and marked with the UR (recognised component) & CSA logos.

## Options

- Seals and disc (\*) <sup>(2)</sup> PTFE: -196°C to +66°C (coil class F / AC Voltage)  
-196°C to +49°C (coil class H / DC Voltage)
- Connector with visual indication and peak voltage suppression or with cable length of 2 m

(\*) Ensure that the compatibility of the fluids in contact with the materials is verified.

<sup>(2)</sup> The minimum ambient temperature of the solenoid valve is determined by the limitations of minimum temperature indicated.

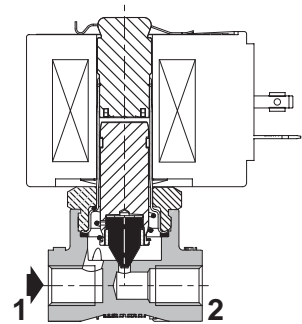
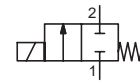

NC function (263 - 1/8)

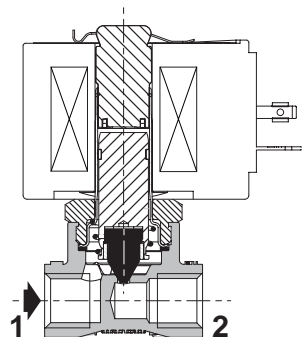

NC function (262 - 1/4)

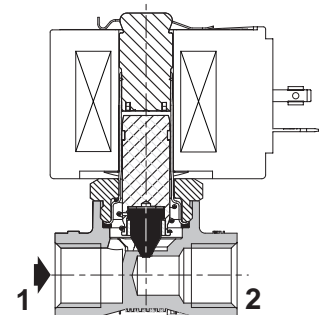

NC function (263 - 3/8)

**Specifications**

pipe size	orifice size (mm)	flow coefficient Kv (m³/h) (l/min)		operating pressure differential (bar)		power coil (W)		thread type	dimensions / type (1)	15-DIGIT PRODUCT CODE								
				min.	max. (PS) cryogenic fluids (*)	~	=			brass	voltage code							
											24V/50 Hz	48V/50 Hz	115V/50 Hz	230V/50 Hz	24V/DC	48V/DC		
<b>Without manual operator</b>																		
<b>NC - Normally closed</b>																		
1/8	3,2	0,3	5	0	10,7	5,2	10,1	11,6	G	01	<b>G263K240S1TD0</b>							
1/4	3,2	0,3	5	0	10,7	5,2	10,1	11,6	G*	01	<b>E262K232S1TD0</b>							
	5,6	0,63	10,5	0	6,9	2,9	17,1	22,6	G*	01	<b>E262K114S1TD0</b>							
3/8	7,1	0,76	12,7	0	4	1,9	17,1	22,6	G*	01	<b>E262K212S1TD0</b>							
	3,2	0,3	5	0	10,7	5,2	10,1	11,6	G*	02	<b>E263K232S1TD0</b>							
	5,6	0,63	10,5	0	6,2	2,9	17,1	22,6	G*	02	<b>E263K206S1TD0</b>							
3/8	7,1	0,76	12,7	0	4	1,9	17,1	22,6	G*	02	<b>E263K210S1TD0</b>							

(1) For dimensions, see drawing(s) for each construction type on the following page(s).

(\*) Ensure that the compatibility of the fluids in contact with the materials is verified.

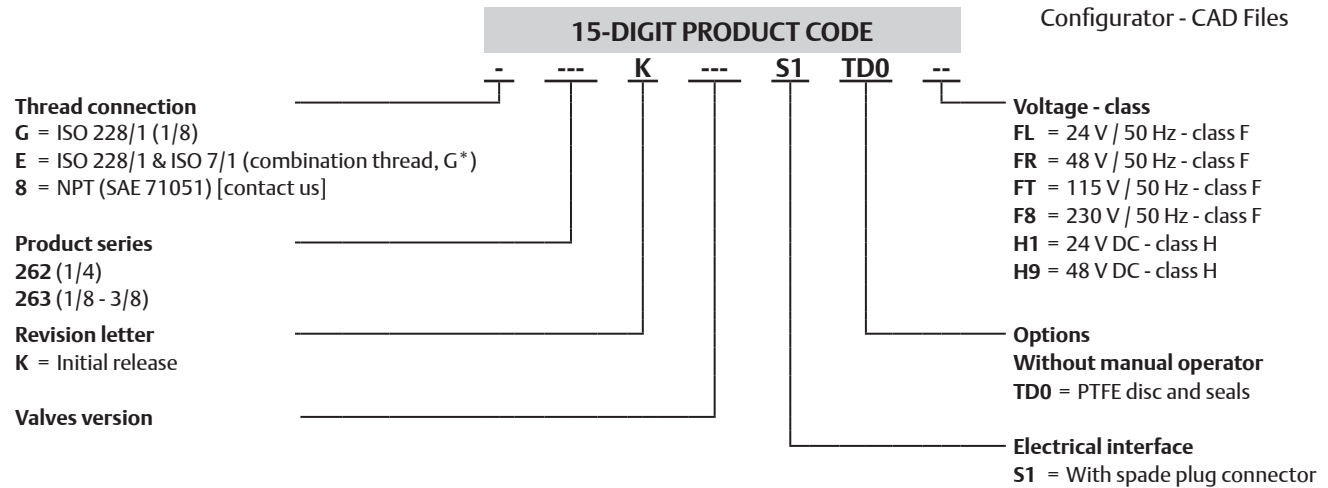

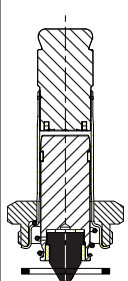
	Spare parts kits no. (*)			
	AC (~)		DC (=)	
		PTFE		PTFE
 G263K240 E262K232 E262K114 E262K212 E263K232 E263K206 E263K210	<b>M200056</b>	<b>TD0</b>	<b>M200057</b>	<b>TD0</b>

01473GB-2020/R01  
Availability, design and specifications are subject to change without notice. All rights reserved.

# ASCO™ Solenoid Valves

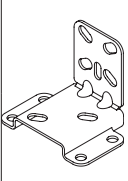
		Accessories code
	Mounting bracket Steel version (AISI 1010 / 1.1121)	<b>M200094A00</b>
	Mounting bracket Stainless steel version (AISI 304 / 1.4301)	<b>M200095A00</b>

## Installation

- The solenoid valves can be mounted in any position without affecting operation
- Solenoid valves have 2 mounting holes in body
- Thread connection “E” applicable for 1/4, 3/8 have standard thread according to ISO 228/1 and ISO 7/1. Thread connection “G” applicable for 1/8, have standard thread according to ISO 228/1
- Thread connection “8” have standard thread = NPT (SAE 71051)
- Installation/maintenance instructions are included with each valve

## Dimensions (mm), Weight (kg)

Configurator - CAD Files



**TYPE 01**  
Electrical interface “S1”  
Epoxy moulded  
IEC 335 / ISO 4400  
IP65

1/8 power coil 10,1 W / 11,6 W

1/4 power coil 10,1 W / 11,6 W - 17,1 W / 22,6 W

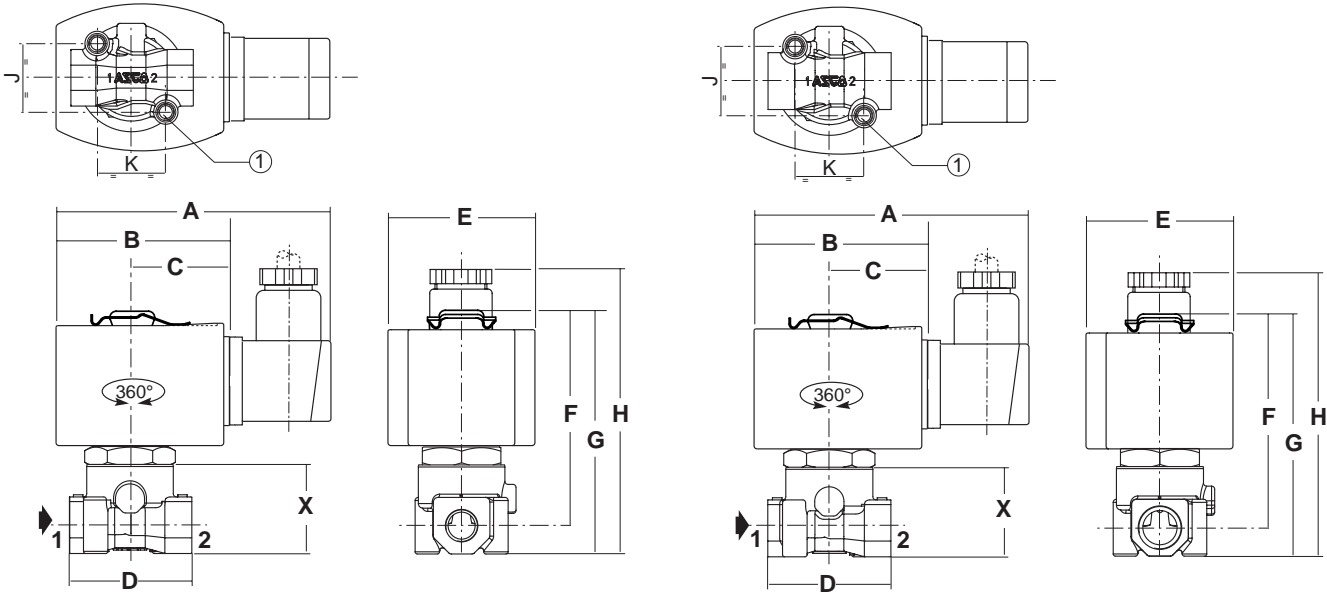

type	pipe size	A	B	C	D	E	F	G	H	X	weight <sup>(1)</sup>
01	1/8	95	57	33	40	50	69	78	93	29	0,54
	1/4	95	57	33	40	50	69	78	93	29	0,58

① 2 mounting holes:  
M5 dia., depth 7,5 mm (1/8-1/4)

<sup>(1)</sup> Incl. coil(s) and connector(s).

01473GB-2020/R01  
Availability, design and specifications are subject to change without notice. All rights reserved.

**Dimensions (mm), Weight (kg)** 

Configurator - CAD Files



**TYPE 02**  
Electrical interface "S1"  
Epoxy moulded  
IEC 335 / ISO 4400  
IP65

3/8 power coil 10,1 W / 11,6 W - 17,1 W / 22,6 W

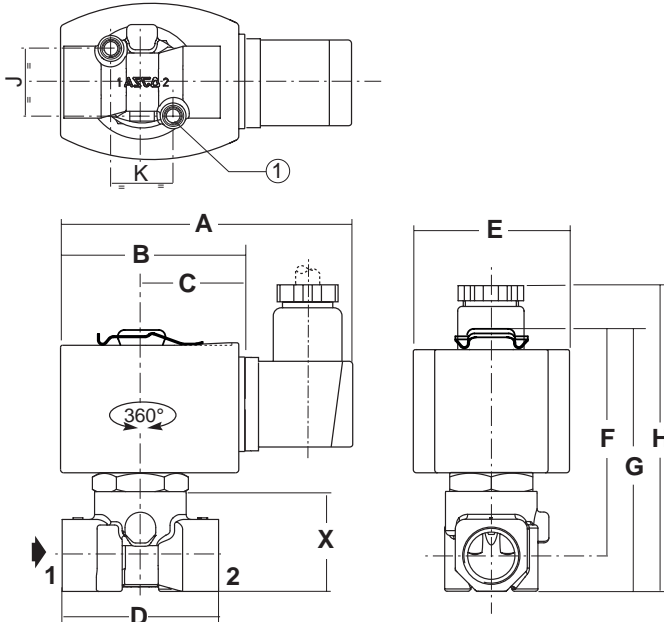

type	pipe size	A	B	C	D	E	F	G	H	X	weight <sup>(1)</sup>
02	3/8	95	59	34	48	50	69	80	95	31	0,61

<sup>(1)</sup> Incl. coil(s) and connector(s).

① 2 mounting holes:  
M5 dia., depth 6 mm (3/8)

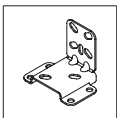

**Mounting bracket**  
Steel or stainless steel

M200094A00 / M200095A00

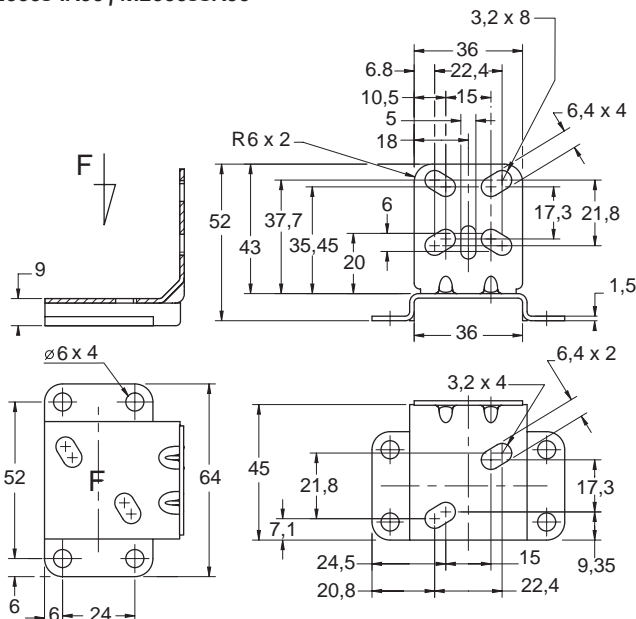

01473GB-2020/R01  
Availability, design and specifications are subject to change without notice. All rights reserved.