

# ASCO™ ASEPTIC VALVES

PRESSURE OPERATED, STAINLESS STEEL OPERATOR, DN 6 TO DN 50

- Pressure operated aseptic valve, designed for the bioprocessing industry.
- The diaphragm separates the piloting from the fluid. It ensures safety and quality of the final product.
- Forged body in-line with the highest material standards. Complies with stainless steel 316L, 1.4435 sulfur controlled to ASME BPE standards, and contain under 0.5% of ferrite.
- Modular compressor design for quick changeover between PTFE and elastomer diaphragm.
- Suited for severe duty applications, such as SIP and high cycle.

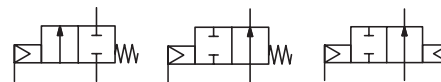

General Valve Information	
Size range	DN 6 to DN 50
Operating mode	Normally closed, normally open, double acting
Max. service pressure	10,3 bar
Max. service temperature	+150°C
Min. service temperature	EPDM diaphragm: -30°C; PTFE diaphragm: -20°C
Max actuator chamber pressure	6,2 bar
Corrosion resistance	Alcohol, chloride and most caustic washdowns

Diaphragm material compatibility *			
Applications		Material	
		EPDM	PTFE
Passivation	Nitric Acid 15% <sup>(1)</sup>	U	R
	Phosphoric 10% <sup>(1)</sup>	R	R
	Citric Acid 15% <sup>(1)</sup>	R	R
	Mixed Chelants <sup>(2)</sup>	R	R
Cleaning <sup>(3)</sup>	Sodium Hydroxide	R	R
	Sodium Hypochlorite	R	R
	Potassium Hydroxide	R	R
	Phosphoric Acid	R	R
	Hydrogen Peroxide	R	R
Sterilization	Saturated Steam 1,4 bar (126°C)	R <sup>(3)</sup>	R
	Saturated Steam 2,1 bar (135°C)	R <sup>(3)</sup>	R
	Saturated Steam 2,8 bar (142°C)	R <sup>(3)</sup>	R
	Dry Heat (165°C)	U	R
	Ozone <sup>(4)</sup>	R	R

\*Ensure that the compatibility of the fluids in contact with the diaphragm is verified.

<sup>(1)</sup> At 60°C

<sup>(2)</sup> Ammonium citrate base at 80°C

<sup>(3)</sup> Limited life and undesirable failure mode

<sup>(4)</sup> 3% at 27°C

<sup>(5)</sup> Consult factory for specific temperature and concentration limitations.

R = Resistant

U = Unsatisfactory

### Diaphragm certifications

- European Union Pressure Equipment directive 2014/68/EU
- FDA compliant
- 21CFR177.2600 – Elastomers
- 21CFR177.1550 – PTFE
- All diaphragms are available with USP class VI certificate of Conformance
- Chapter 87 In-Vitro
- Chapter 88 In-Vivo
- Certificate of compliance to EMEA/410/01 “Guidance on Minimizing the Risk of Transmitting Animal Spongiform Encephalopathy Agents via Human and Veterinary Medicinal Products” available on demand.
- Certificate of traceability to EN 10204 3.1 B available upon request.

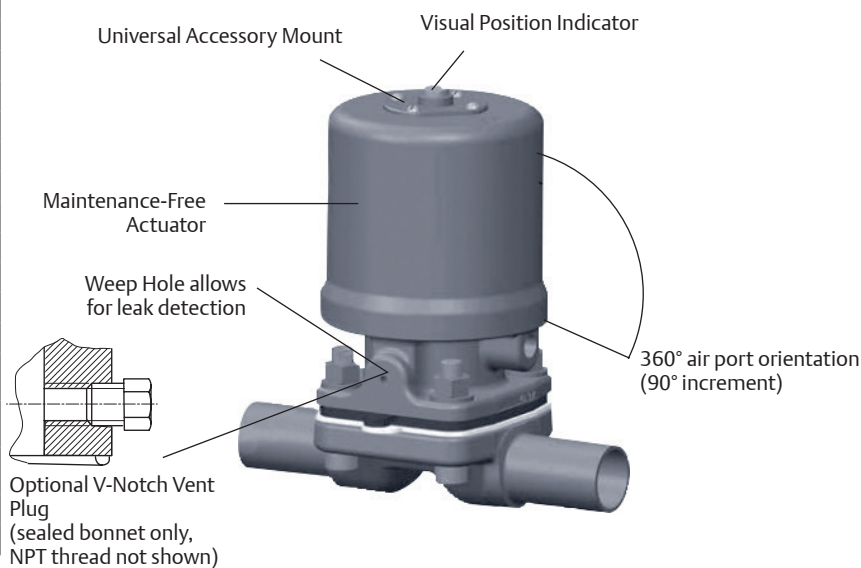

01484GB-2019/R01 Availability, design and specifications are subject to change without notice. All rights reserved.



**Drain angle**

Aseptic valve may be installed in vertical or horizontal lines, as required. Drain marks are provided as a standard on a forged body to facilitate installation and optimized drainability. One mark must be located in the vertical plane, cutting the centerline of the pipe.

Valve Size (IN)	Valve Size (DN)	ANSI	ISO	DIN
0.25"	6	30°	20°	20°
0.5"	15	30°	20°	20°
0.75"	20	30°	21°	25°
1"	25	30°	22°	26°
1.5"	40	28°	17°	22°
2"	50	23°	16°	19°

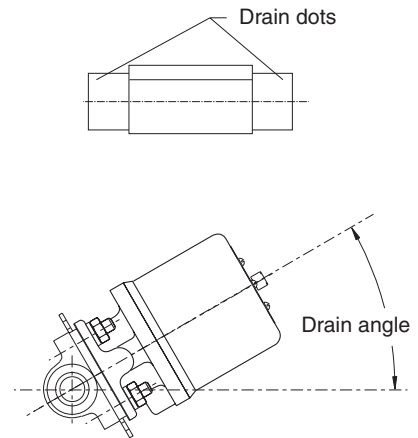

**Surface finish**

Valve bodies are available in a complete range of mechanically or electropolished surface finishes to satisfy system design requirements.

Electropolishing is the electromechanical method of removing metal from the surface. This surface finishing improves corrosion resistance, removes inclusions and improves the overall surface for cleaning and sterilization.

Mechanical Polish	EU Service Micron Max.
	No Mechanical Polish
	0.8Ra
	0.6Ra
	0.5Ra
	0.38Ra
Electropolish	0.28Ra
	0.25Ra
	No Electropolish
	Both Interior and Exterior Electropolish

**How To Order**

**Product Code**  
A 224 B 9 1 P 000001

A = All connexion possible

**Product series**  
224 = Aseptic Valve

**Revision letter**  
B = ITT supplier identification

**Actuator type**  
9 = Pneumatic Actuator ACS

**Series**  
Sequential

**Diaphragm material**  
P = E (PTFE)  
E = E (EDPM)

**Valve Size**  
1 = 1/4" (DN6) 0.25"  
4 = 1/2" (DN15) 0.5"  
5 = 3/4" (DN20) 0.75"  
6 = 1" (DN25)  
8 = 1 1/2" (DN40) 1.5"  
9 = 2" (DN50)

## Dimensions: mm (Body)

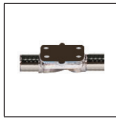

**Type 01**  
butt welding connection

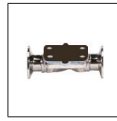

**Type 02**  
clamp connection

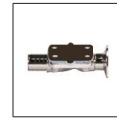

**Type 03**  
clamp connection +  
butt welding connection

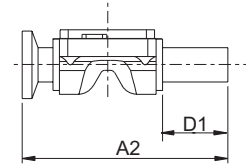
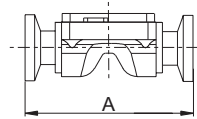
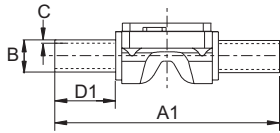

ANSI Forging										SMS	
B		A	A1	D1	A2	C				B	C
End connection size		Overall length (mm)	Overall length (mm)	Weld Tangent (mm)	Overall length (mm)	20 GA 0.812	18 GA 1.02	16 GA 1.29	14 GA 1.63		
IN	DN	Clamp	Extended BW Forging	Extended BW Forging	Clamp x butt welding connection (BW)	Extended BW	Extended BW ASME BPE	Extended BW	Extended BW ASME BPE	butt welding connection (BW)	
0.25"	6	64	89	25	76,2	S	O				
0.5"	15	89	128	38	108,7	O	O	S	O		
0.75"	20	102	140	38	120,7	O	O	S	O		
1"	25	114	151	38	132,6		O	S	O	25	1,2
1.5"	40	140	173	38	156,2		O	S	O	38	1,2
2"	50	159	188	38	173,7			S	O	51	1,2

ISO										DIN Serie 1		DIN Serie 2		DIN Serie 3		
End connection size		A (mm)	D1 (mm)	B (mm)	C						B (mm)	C (mm)	B (mm)	C (mm)	B (mm)	C (mm)
					1	1.2	1.6	2	2.3	2.6						
DN6		89	25	8	S	O					8	1				
DN15		106	25	21,3			S	O			18	1	19	1,5	20	2
DN20		118	25	26,9			S	O			22	1	23	1,5	24	2
DN25		127	25	33,7			O	S			28	1	29	1,5	30	2
DN40		174	35	48,3			O	S			40	1	41	1,5	42	2
DN50		191	35	60,3				S	O	O	52	1	53	1,5	54	2

O = Optional  
S = Standard

01484GB-2019/R01 Availability, design and specifications are subject to change without notice. All rights reserved.

Dimensions: mm (Actuator)

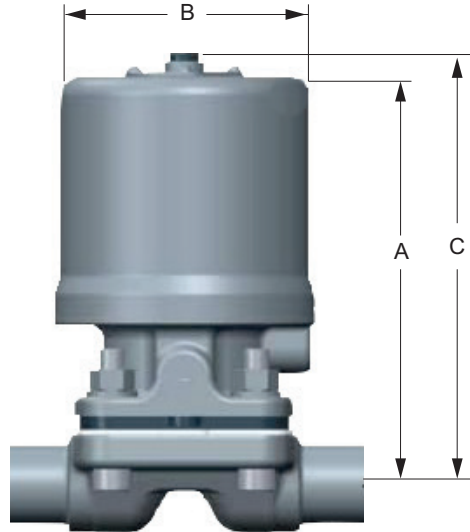

Valve Size (DN)	A (mm)	B (mm)	C (mm)
6	90,2	44,5	99,1
15	107,7	66,5	114
20	131,6	79,2	141,2
25	138,2	79,2	150,9
40	229,9	117,3	250,4

01484GB-2019/F01  
Availability, design and specifications are subject to change without notice. All rights reserved.